

# MODERN METHODS OF FORD REPAIRING

**A** COMPLETE manual for the Ford repairman, explaining the use of all the up-to-date tools and shop equipment and minutely describing the methods of performing the work on all the different mechanical parts of the car.

*By*

J. HOWARD PILE

U. P. C. Book Company, 243-249 W. 39th St., N. Y.

TL-208  
P5

Copyright 1920

By

U. P. C. BOOK COMPANY, Inc.

TO THE  
LIBRARY OF  
THE UNIVERSITY OF  
MICHIGAN

## PREFACE

THE business of repairing Fords has come to be such an enormous one and open to such competition that the man who expects to make a success of it is forced to use the most up-to-the-minute methods, tools and machinery available for the purpose. This book is designed to give in a clear, concise and thorough way all the detail operations in repairing and overhauling the Ford mechanical units using the best and quickest methods and employing the tools and machinery that will save time and labor and insure jobs as nearly perfect as it is possible to get out.

Service work on all makes of cars is slowly but surely turning toward factory production methods and this is more true of Ford service than of any other car. Repairmen are realizing that to "produce" service in quantity and at a low figure it is of vital importance to specialize and to use special tools and equipment. The "all around" mechanic is rapidly giving way to the "motor" man or the "rear assembly" man. When a man specializes on one job, he becomes more proficient, does the job quicker and also does it better.

With the use of modern production methods and special tools, Ford service work is not only speeded up but is *made better*. The repairs are standardized

and the mechanic is less liable to make a mistake than under the old "monkey wrench and hammer" method.

In the preparation of this material the writer studied the methods used in the Ford factory and branches in the manufacture and assembly of the car in the first place and then observed the methods in general use in the largest and best-equipped Ford repair shops. These were then melted together, so to speak, and the result is given on the pages of this book. There is no mere theory about any of the methods used, as they are all in practical use in Ford service stations.

J. HOWARD PILE.

January, 1920.

## Table of Contents

	Page		Page
CHAPTER I		CHAPTER IX	
System and Handling Ford Service.....	7	Fitting the Piston Pin.....	57
CHAPTER II		CHAPTER X	
Labor Operations Covering Repair Work on Model T Ford Cars.....	12	Aligning the Connecting Rod.....	59
CHAPTER III		CHAPTER XI	
Removing the Engine from the Car..	25	Fitting the Piston Rings on New and Old Pistons .....	63
CHAPTER IV		CHAPTER XII	
Taking Down the Engine.....	31	Burning In the Bearings.....	68
CHAPTER V		CHAPTER XIII	
Testing and Straightening the Crank- shaft .....	43	Testing and Overhauling the Magneto	81
CHAPTER VI		CHAPTER XIV	
Rebabbitting the Cylinder Block.....	46	Overhauling the Transmission.....	96
CHAPTER VII		CHAPTER XV	
Reboring the Cylinders.....	49	Reseating and Grinding Valves and Other Minor Engine Repairs.....	110
CHAPTER VIII		CHAPTER XVI	
Fitting New Pistons.....	54	The Carbureter.....	116

	Page		Page
CHAPTER XVII		CHAPTER XXIII	
Assembly of Engine and Transmis- sion .....	128	The Rear Axle Assembly.....	186
CHAPTER XVIII		CHAPTER XXIV	
The Ignition System.....	139	Miscellaneous Parts.....	197
CHAPTER XIX		CHAPTER XXV	
Testing the Engine.....	150	Care and Repair of the F. A. Starting and Lighting System.....	203
CHAPTER XX		CHAPTER XXVI	
The Radiator .....	162	Reading Wiring Diagrams with Blue- prints of 25 Internal and External Circuits Used on Ford Cars.....	213
CHAPTER XXI			
Engine Numbers.....	170		
CHAPTER XXII			
The Front Axle Assembly.....	175		

## CHAPTER I

### System in Handling Ford Service

**S**UCCESSFUL Ford service requires system in routing the jobs. A careful record of each job from the time it enters the shop till the time it leaves and is paid for is absolutely essential. No matter how large or how small the shop, a standard Ford repair order must be made out, giving the details of the work that is to be done. This is signed by the customer. The standard operations are written on the repair order *by name* and the price put down. All that is necessary thereafter is to enter up the parts used in effecting the repairs.

#### The Repair Order

The repair order is part of the system and hooks up with the routing of the work, so a perfect understanding of it is necessary. There are three sheets, the original (Fig. 1), the duplicate which is

identical, and the instruction card (Fig. 4). Two sheets of carbon paper duplicate what is written on the original on the duplicate and instruction card. Fig. 3 is the reverse of both the original and duplicate sheets, illustrated in Fig. 1.

The original is filled in with the following details when the customer brings the car in:

Deliver to (owner's or driver's name).  
Month, day and year.  
Address.  
Telephone number.  
Engine number.  
License number.

Work to be performed (this is itemized by individual operations corresponding to the list of labor operations).

Prices (for labor only).

Owner's or driver's signature authorizing the work.

The original is the office copy. It









prices of the parts added up and transferred to the front of the sheet opposite the heading "material." The addition of "materials" and "labor" will be the total amount that the customer is to pay.

The "materials" items, together with the total and the addition on the front are transcribed to the "original," which is delivered to the customer when he pays the bill and takes the car away.

The instruction card will have dupli-

cated on it the work to be done on the car. There are two stubs which are detachable by means of perforations, one of these being the claim check which is delivered to the customer to identify him when he calls for the car and the other is the "record" which is put in a small box in the office for the purpose of keeping track of the job. The instruction card goes with the car on its journeys through the shop.

## CHAPTER II

### Labor Operations Covering Repair Work on Model T Cars

(Suggested by the Ford Motor Company as a Guide for Dealers and Garages)

#### Segregation of Work

**F**ORD service work is highly specialized and with few exceptions any one operation is the same on every car. It is a great advantage, therefore,

be given unless the size of the shop is known, but the schedule given below of men and duties for a force of 12 men may be easily enlarged or contracted to suit conditions.

Service Manager	}	Cashier—Takes care of office work, adding up bills, receiving and paying out cash, etc.
		Tester—Receives cars at door, determines troubles, makes out repair orders and delivers finished cars to customers
		Shop Foreman {
		1 man for bearings, pistons and cylinder work
		1 man for transmissions, tearing down and assembly
		1 radiator man for soldering, welding and brazing
		1 rear axle man
		1 painter and trimmer
		1 helper
		Stock Clerk
		Porter

to segregate the work in the shop so that certain men specialize on certain jobs. No actual apportionment of the work can

It is not necessary to adhere rigidly to the schedule, because when work slackens up in any department, one or more men

can be shifted to a busier department or some of the men can be set to work reclaiming parts and salvaging material.

### Arrangement of Departments

As far as possible the departments for the different classes of work should be separated and should be progressive so that the car keeps moving in the same direction and does not double on its tracks from the time it enters the shop till it leaves. If the building has a number of floors, a good routing is to start at the top floor and end on the ground floor. If the building is all on one floor, start at one end and finish at the other.

### Disposition of Old Material

The old material that is removed from the cars during the various repair operations is all saved. Each department should be provided with at least two large boxes mounted on castors. One of these is marked SALVAGE BOX and the other JUNK BOX. These boxes are shown in Fig. 5.

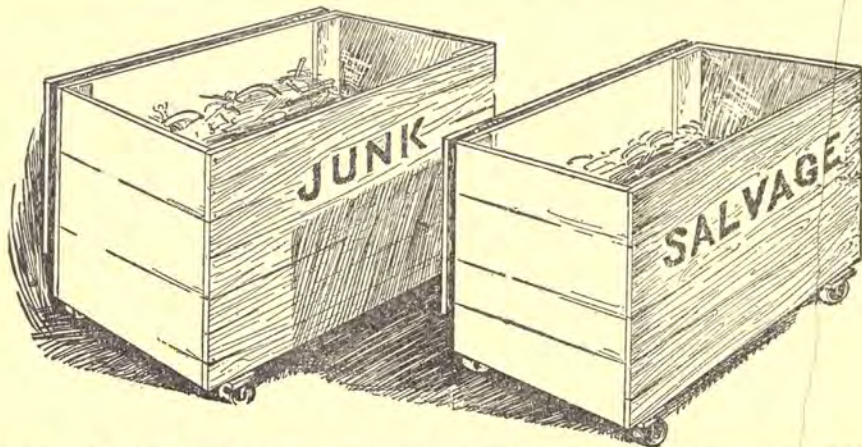
The salvage box is to receive all parts

which are fit for use again after having some work done on them or having some new parts put on. Brakerod supports, fender irons, transmission bands, engine pans and other items which do not WEAR OUT in use but simply become bent or otherwise unfit for present use can be salvaged by straightening, painting, etc.

The following list of labor operations on the Ford has been compiled by the Ford Motor Co., with the charges that are suggested as being reasonable. Much latitude should be allowed, however, circumstances making it necessary to increase these charges by amounts up to 25 per cent. Where the shop is a large one and the work can be routed through the shop along with a similar class of work it is perfectly possible to make a reasonable profit on the prices as listed. Where the shop is a small one, with one, two or three workmen, each job assumes the character of an individual operation, one man does all classes of work and it is impossible to maintain the speed and departmentization that is so necessary in getting results.

The right way to use this list is to make a careful study of the individual

shop. If there is any way to speed up the performance with the limited amount



*Fig. 5—The junk and salvage boxes are mounted on castors and have hinged lids*

operations and then compare the prices with the average time records for the same operations as performed in your

of help available, then the cost of doing the job may be cut down in this way, but if things are going as fast as it is pos-

sible for them to go, then the only other remedy is to adjust the scale to take care of this still keeping in mind that competition will force you either to pare the price or take business away from you. Aim to give the greatest amount of service possible and still make a profit, but do not do business without a profit.

The prices given in the list were in effect Dec 1, 1919.

### Engine Division

The following charges cover work on cars driven into the service stations:

<i>Operation Number</i>	<i>Labor Charges</i>
1. Overhaul engine and transmission .....	\$25.00
2. Overhaul engine only .....	20.00
3. Overhaul transmission only, or repair or replace magneto...	14.00
4. Rebraze crank case arms or support or repair leak in case by taking out the engine	12.00
5. Install or refit one piston or one connecting rod.....	4.50
6. Install or refit two or more pistons or connecting rods.....	6.00

7. Tighten one connecting rod bearing .....	\$2.50
8. Tighten two or more connecting rod bearings .....	4.50
9. Replace transmission bands (Sedans and Coupes, \$1.00 extra) .....	2.75
10. Replace transmission cover gasket .....	2.50
11. Change engine .....	6.50
12. Replace cam shaft, and refit bearings .....	5.00
13. Replace cam gear—large.....	2.50
14. Replace cylinder front cover..	2.50
15. Grind valves and clean carbon	3.00
16. Remove carbon only. (This operation to be used only when customer will not permit grinding of valves)....	1.75
17. Repair cylinder head bolts stripped—one or two.....	2.50
18. Repair cylinder head bolts stripped under dash.....	5.00
19. Clean out oil feed pipe.....	3.25
20. Replace cylinder head gasket.	1.00
21. Replace radiator or all three hose connections .....	.60
22. Replace one hose connection only .....	.40

23. Replace crank shaft starting pin, or pulley .....	\$1.50	Operations 5 and 15 combined on one order .....	\$6.00
24. Tighten engine to frame.....	1.25	Operations 6 and 15 combined on one order .....	7.50
25. Clean crank case or install gasket under lower cover ..	.75	Operations 12 and 15 combined on one order .....	6.50
26. Replace carburetor or manifold—or repair leak in manifold .....	.75	Operations 15 and 17 combined one one order .....	4.00
27. Install new butterfly spring...	.75	Operations 9 and 19 combined on one order .....	5.00
28. Overhaul carburetor .....	1.50	Operations 10 and 19 combined on one order .....	4.75
29. Repair leaky carburetor .....	1.00	Operations 30 and 31 combined on one order .....	.75
30. Replace commutator wire loom .....	.60	No charge for operation 10 when combined with operation 9.	
31. Replace commutator case or brush .....	.50	No charge for operation 16 when combined with operations 5, 6 or 12.	
32. Replace commutator pull rod joint .....	.60	No charge for operation 21 when combined with operations 228 or 238.	
33. Replace or rebush fan pulley assembly .....	.60	No charge for operation 34 when combined with operation 9.	
34. Adjust clutch fingers and trans. bands .....	.60	No charge for operation 21 when combined with operation 14.	
35. Adjust trans. bands only.....	.40		
36. Stop oil leak in valve doors....	.50		
37. Install trans. band springs—each .....	.50		
38. Replace cylinder water jacket plug—one or more .....	.40		
39. Install new starting crank handle .....	.50		



**Parts Brought in or Shipped in for Repairs**

55B. Overhaul engine and transmission .....	\$15.75
56B. Overhaul engine only.....	11.00
57B. Overhaul transmission only..	4.00
58B. Rebore cylinder only .....	1.50
59B. Rebore cylinder only including refitting of pistons....	2.55
60B. Rebore and rebabbitt cylinder including fitting of pistons .....	3.75
61B. Rebabbitt cylinder only.....	1.50
62B. Rebabbitt cylinder, fit crank shaft, and run-in.....	2.25
63B. Rebore and rebabbitt cylinder, including fitting of pistons, crank shaft, connecting rods and running in...	5.00
64B. Rebore and rebabbitt cylinder, fit pistons, valves, push rods, cam shaft, crank shaft connecting rods and run-in .....	7.50
65B. Rebore and fit pistons and valves .....	2.75
66B. Rebore and fit pistons, valves and push rods and straighten and fit cam shaft.....	3.50

67B. Fit pistons, crank shaft and run-in (rebored block) ....	\$1.25
68B. Rebush three transmission drums .....	1.50
69B. Rebush transmission drums—each .....	.60
70B. Rebush and re-rivet three triple gear assemblies....	1.25
71B. Braze crank case arms and supports .....	3.00
72B. Repair crank case drain plug housing .....	2.00
73B. Overhaul and repair carburetor .....	1.00
74B. Disassemble $\frac{5}{8}$ " , $\frac{9}{16}$ " or $\frac{3}{4}$ " magnets from flywheel and install new set .....	.60
75B. Straighten crank shaft .....	1.00
76B. Straighten cam shaft .....	.60
77B. Straighten cam shaft and fit bearings .....	1.00
Operations 71B and 72B combined in one order .....	3.00

Note:—When the cylinder block is brought in or shipped in to the Dealer for operations Nos. 58B, 59B, 60B, 61B, 62B, 65B, or 66B, and it is necessary to send the block to the nearest Branch for rebor-

ing or rebabbiting, the Dealer may add \$1.00 to the regular charge to cover expense of handling the transaction.

### Rear System Division

The following charges cover work on cars driven into the service stations:

96. Overhaul rear axle and rebush springs and perches when necessary .....	\$ 6.00	105. Straighten axle shaft (without removing from car)...	\$1.50
97. Repair or replace drive shaft tube .....	4.00	106. Tighten rear radius rod.....	.75
98. Repair or replace one rear radius rod .....	1.50	107. Install felt and steel washers—one side .75—both sides .....	1.25
99. Replace rear spring tie bolt or new leaf including polishing and graphiting of leaves and lining up of body .....	3.00	108. Install brake shoes and equalize emergency brakes—one shoe .75—both .....	1.25
100. Remove front and rear springs, polish and graphite leaves only .....	3.00	109. Tighten universal ball cap bolts .....	.60
101. Replace spring perches—one .75—both .....	1.25	110. Install or tighten rear spring clips .....	.60
102. Pad rear spring to line up body or replace rear spring tie bolt only .....	1.50	111. Tighten rear hub lock nut—one side .40—both sides..	.60
103. Rebush spring and perches..	2.00	112. Fit new hub keys—one side .50—both sides .....	.75
104. Install universal joint .....	2.75	113. Replace pull rod supports—one support .40—both supports .....	.60
		114. Replace or rebush hub brake cam—each side .....	1.50
		115. Replace rear axle assembly..	2.50
		116. Adjust pull rods or replace one .....	.75
		117. Straighten rear radius rod (in car) .....	.75
		118. Install outer roller bearing—each .....	1.25

119. Replace rear axle shaft, drive shaft pinion, or drive gear (no other work necessary).	\$3.00
Operations 96 and 99 combined on one order.....	7.25
Operations 96 and 102 combined one one order.....	6.50
Operations 96 and 110 combined on one order.....	6.25

The following extra charges should be made for special equipment:

Axle overhaul when necessary to remove special trunk racks or truss rods..	1.00
Axle overhaul, when car has shock absorbers and owner will not permit removal..	1.00
Axle overhaul, when car is equipped with special hub brakes .....	1.50

**Parts Brought in or Shipped in for Repairs:**

140B. Overhaul rear axle.....	4.00
141B. Straighten or repair rear radius rod .....	.60
142B. Overhaul differential assembly with shafts.....	1.50
143B. Remove old and press new gear on axle-shaft—each.	.40

**Front System Division**

The following charges cover work on cars driven into the service stations:

167. Overhaul front axle, including rebushing of springs and perches when necessary, straightening and lining up and adjusting of wheels...	5.00
168. Rebush spindle bodies and arms—each side .....	1.50
169. Replace or straighten front axle (no other repairs)....	2.50
170. Rebush spindle body—each...	1.00
171. Rebush spindle arm—each...	.75
172. Replace broken off radius rod ball cap stud .....	2.50
173. Replace front spring tie bolt or new leaf, including polishing and graphiting of leaves .....	2.50
174. Replace front spring or tie bolt only .....	1.50
175. Install or tighten front spring clips—one .40—both .....	.60
176. Tighten radius rod or steering gear ball cap .....	.60
177. Replace radius rod .....	.75
178. Straighten front radius rod and line up front assembly	1.00

179. Replace spindle arm or body and line up assembly . . . . .	\$ .75
180. Replace radius rod ball cap with new style . . . . .	.60
181. Tighten all sockets and joints of front end . . . . .	1.25
182. Replace or straighten spindle or steering gear connecting rod . . . . .	.60
Operations 167 and 172 combined on one order . . . . .	6.50
Operations 167 and 173 combined on one order . . . . .	6.50
Operations 167 and 208B combined on one order . . . . .	6.50

The following extra charges should be made for special equipment:

Overhauling front axle when bumpers, special radius rods, and such devices are used . . . . .	1.50
---	------

#### Parts Brought in or Shipped in for Repairs:

202B. Straighten front axle . . . . .	1.50
203B. Straighten radius rod . . . . .	.60
204B. Install stud in radius rod . . . . .	.75
205B. Rebush spindle body and arm . . . . .	.75
206B. Rebush spindle arm . . . . .	.40

207B. Rebush spindle body . . . . .	\$8.50
208B. Rethread front axle by drilling out and bushing . . . . .	2.00

#### Chassis Division

The following charges cover work on cars driven into the service stations:

#### Front End and Frame

228. Replace front cross member . . . . .	6.00
229. Replace front cross member when radiator is off . . . . .	5.00
230. Straighten front cross member (without removing from car) . . . . .	3.00
231. Replace rear cross member . . . . .	7.50
232. Replace side member or frame . . . . .	20.00
233. Install engine pans—one .75 —both . . . . .	1.25
234. Tighten engine pan . . . . .	.60
235. Tighten crank case front end bearing cup . . . . .	1.00
236. Install hood clips or springs on hood board—each side . . . . .	.60
237. Free up hand brake lever . . . . .	.60
238. Remove radiator to replace radiator stud or tighten fender brackets—each or both . . . . .	1.00

239. Replace starting crank ratchet pin .....	\$ .60
240. Replace starting crank or sleeve .....	1.25
241. Install running board bracket .....	2.50
242. Repair hand brake lever assembly including replacing of pawl .....	1.00
243. Replace hand brake lever quadrant without removing running board shield .....	1.25
244. Tighten all bolts and nuts on car .....	3.00
245. Tighten body bracket bolts ..	1.00
246. Install tail lamp bracket.....	.60

#### Fenders and Running Boards

258. Replace one fender or running board (.25 extra when necessary to straighten iron or bracket) .....	.75
259. Tighten all fenders, running boards, shields and truss rods—one only .40—.....	1.75
260. Remove fender or running board and straighten .....	1.00
261. Replace running board shield—one \$1.25—two .....	2.00
262. Install fender-to-shield bracket—each .....	.60

263. Install metal tool box .....	\$ .75
264. Replace rear fender iron ....	.75
265. Replace truss rods—one rod .40—both rods .....	.60

#### Dash

276. Replace dash .....	4.50
277. Replace dash when engine is out .....	1.50
278. Tighten dash bracket to body and dash .....	1.25
279. Replace coil and install Yale lock .....	1.50
280. Replace coil, install new switch on coil box or repair the box .....	.60

#### Steering Gear

291. Overhaul steering gear including replacing of quadrant or gear case and rebushing of bracket .....	3.50
292. Overhaul steering gear when engine is out .....	2.50
293. Tighten rivets of internal gear case .....	1.25
294. Tighten at dash and rebush bracket .....	1.25
295. Replace wheel or spider .....	.60

296. Tighten at dash and post....	\$ .75	349. Install new core in radiator..	\$6.00
297. Replace steering gear assembly .....	3.00	350. Repair radiator, solder one or two tubes and replace one or both sides .....	4.00
298. Rebush bracket only .....	.75	351. Solder neck or top tank or repair without removing from car .....	1.00
299. Tighten steering gear case cover .....	.75	352. Solder casting to lower or top tank when necessary to remove radiator .....	1.50
<b>Muffler</b>		353. Replace broken pet cock .....	.60
310. Change long exhaust pipe...	.75	<b>Wheels</b>	
311. Replace muffler .....	.60	365. Change hub, rear or front....	1.25
312. Repair muffler .....	1.00	366. Replace wheel and tire—each	.75
313. Repack exhaust pipe pack nut .....	.60	367. Adjust and dope front wheels	.60
<b>Gas Tank and Line</b>		368. Remove front wheels and replace bearing parts—one wheel .75—both .....	1.25
323. Repair leak in touring car gas tank .....	1.50	369. Line up front wheels (when necessary to replace spindle arm .60) .....	.40
324. Repair leak in touring car gas tank (when necessary to remove body) .....	6.00	370. Oil and dope car (including material) (Graphiting springs in car .75 extra)..	.75
325. Clean sediment bulb, gasoline feed line and drain carburetor .....	.75	<b>Paint Division</b>	
<b>Hood</b>		391. Repaint and revarnish chassis only .....	12.00
336. Straighten hood .....	1.00		
337. Install hood leather .....	.60		
<b>Radiator</b>			
348. Overhaul radiator (requiring 4 to 7 hours' time).....	7.50		

392. Repaint and revarnish car— Touring or Runabout . . . . .	\$25.00	418. Re-upholster Touring body (using new material) . . . . .	\$10.00
393. Repaint and revarnish Coupe- let . . . . .	35.00	419. Re-upholster Runabout body (using new material) . . . . .	6.00
394. Repaint and revarnish Sedan .	45.00	420. Change closed body . . . . .	8.00
395. Repaint and revarnish body only—Touring or Runabout . . . . .	15.00	421. Change Touring or Runabout body . . . . .	5.00
396. Revarnish body only—Touring or Runabout (on chassis) . . . . .	5.00	422. Take dent out of any side panel . . . . .	4.00
397. Revarnish body only—Sedan or Coupelet (on chassis) . . . . .	12.00	423. Take dent out of any side panel and refinish . . . . .	5.00
398. Refinish deck on Torpedo Run- about . . . . .	1.50	424. Take dent out of door . . . . .	2.00
399. Refinish fenders, dust shields, running boards, wheels, or hood off car, each . . . . .	.75	425. Take dent out of door and refinish . . . . .	3.00
<b>Body Division</b>		426. Take dent out of rear or cor- ner panel without removing from car . . . . .	6.00
411. Tighten all doors . . . . .	1.25	427. Take dent out of rear or cor- ner panel and refinish with- out removing from car . . . . .	10.00
412. Install new lock—Touring or Runabout—each . . . . .	1.00	428. Take dent out of rear or cor- ner panel (when removed from car) . . . . .	13.00
413. Replace Town Car or Sedan door lock . . . . .	1.50	429. Take dent out of rear or cor- ner panel and refinish (when removed from car) . . . . .	16.00
414. Replace top irons—each . . . . .	1.00	430. Take dent out of Torpedo deck and refinish . . . . .	2.00
415. Install new leather on door panel—one .60—two . . . . .	.75	431. Repair front or rear seat cushion . . . . .	2.50
416. Install new leather on arm rest . . . . .	1.00		
417. Patch section of upholstering	1.00		

432. Replace binding on one or more doors . . . . .	\$ .75	469. Replace windshield—and line up windshield frame . . . . .	\$1.00
433. Put on new trim rail . . . . .	2.50	470. Replace windshield glass—upper . . . . .	.60
434. Replace door hinge . . . . .	.75	471. Replace windshield glass—lower . . . . .	1.00
<b>Top and Windshield Division</b>			
455. Overhaul Touring Car or Torpedo top including recovering, lining-up and fitting of curtains . . . . .	7.50	472. Replace hinge . . . . .	.60
456. Replace top deck or side quarters—each or both . . . . .	4.50	473. Replace or tighten dash clips and hinge screws . . . . .	.50
457. Line up and dress top . . . . .	2.00	474. Pack windshield glass or take out rattle—each . . . . .	1.00
458. Install and fit top . . . . .	1.25	475. Replace windshield bracket..	1.50
459. Repair tear in top up to 4 in.	1.00	476. Repair windshield lower frame—and install glass . . . . .	1.75
460. Replace front or rear bow—Touring or Runabout . . . . .	2.50	<b>Lamp and Horn Division</b>	
461. Replace center bow—Touring or Runabout—each . . . . .	1.25	502. Replace or repair electric headlight switch . . . . .	.60
462. Patch small pin holes . . . . .	.60	503. Straighten damaged headlamp	1.25
463. Patch hole in curtain or replace celluloid . . . . .	.60	504. Take dent out of head lamp door frame and replace glass . . . . .	.75
464. Replace back curtain . . . . .	1.50	505. Clean up and repair set of oil lamps . . . . .	1.00
465. Replace celluloid in back curtain . . . . .	1.75	506. Install electric horn and wire	1.00
466. Refit complete set of side curtains . . . . .	1.50	507. Install electric headlights and wire . . . . .	1.50
467. Refit one side curtain .60—two	.75	508. Install new parts in oil lamps—each . . . . .	.60
468. Replace top bow socket—Touring or Runabout . . . . .	1.25	509. Take short-circuit from switch or lamp . . . . .	.60



## CHAPTER III

### Removing the Engine from the Car

**I**T is an economy of time for a man and helper to work together on this job, the man doing the more important things and the helper the less important. The numbered operations in plain type are to be performed by the man and the lettered operations in *italics* by the helper.

A parts box mounted on castors and divided into compartments is provided to receive the parts of the engine which are to be used again. The box is divided into a number of compartments so that the parts can be kept separate. If the box is marked with the job number and is left undisturbed until the engine is assembled again, there will be little chance of the parts getting lost or mislaid.

A list of parts that are to be replaced with new ones should be made out on a card *as the old parts are junked or salvaged*. This will save time in assembly

as all the parts needed can be secured from the stockroom at one trip instead of making a number of trips as the items are needed.

*A—Remove the hood.*

*B—Drain the radiator into a bucket. If the water does not run out freely when the petcock is opened, stick a wire up through the opening to break up the mud and sediment. If the petcock will not turn after applying reasonable pressure, loosen the screw a half turn if it is in position to make this possible and tap the screw lightly. The key in the petcock is tapered and this tapping will loosen it in its seat so that it can be turned.*

1—Disconnect the four wires from the spark plugs.

2—Remove the cotter pin from the timer rod, slip it out and unsnap the timer case with its wires in place and lay it aside till later.

*C—Remove the rubber mat, the front cushion and the three floor boards from the driver's compartment.*

3—Disconnect the wire from the magneto terminal.

4—Loosen the radiator stay rod from the radiator with a pipe wrench and loosen the locknut at the dash.

5—Disconnect the headlamp wires.

*D—Drive a broad, flat screwdriver or a small flat cold chisel in between the frame and the square nuts on the lower ends of the radiator stud bolts to keep them from turning while the nuts are removed from the top. See Fig. 6.*

*E—Remove the cotter pins from the tops of the radiator stud bolts.*

6—Unscrew the brass nuts with a  $\frac{3}{8}$ -in. speed wrench. If the nuts are corroded fast, it will be necessary to start them with a  $\frac{3}{8}$ -in. open-end wrench, turning them off with the speed wrench after they are loosened a little.

*F—Take off the brass washers.*

The radiator is now ready to be disconnected from the engine.

7—Remove the two cap screws from the outlet water connection with a 7/16-in. S. A. E. end wrench.

8—Remove the two cap screws from the inlet water connection with a short handled 7/16-in. T-wrench.

9—Remove the radiator by lifting it straight off the studs. The hoses and water connections to the cylinder block will come off with the radiator. Hang the two copper-asbestos gaskets and the leather pads from under the radiator on one of the nails on the side of the parts box. If the rubber hoses are to be renewed—

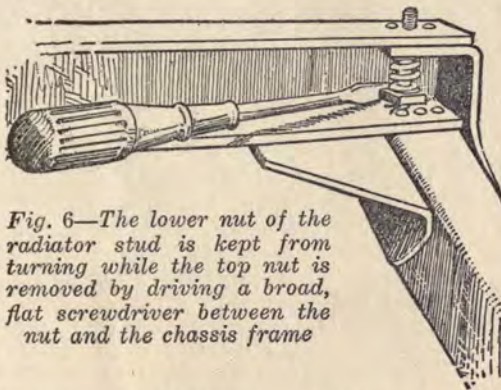
*G—Loosen the six hose clamps with screwdriver and pair of pliers and cut the old hose off with a knife. Junk the hose and such of the hose clamps as are gone or unfit for use again and put the remainder in the parts box together with the outlet connection pipe, inlet connection and outlet connection.*

*H—Remove the spark plugs with the spark-plug wrench.*

10—Remove the throttle rod by taking

out the cotter pins at both ends and slipping the ends out of the throttle arm and the arm on the steering column.

11—Push the carbureter dash control up out of the way.



*Fig. 6—The lower nut of the radiator stud is kept from turning while the top nut is removed by driving a broad, flat screwdriver between the nut and the chassis frame*

*I—Turn off the gasoline at the tank.*

12—Disconnect the gasoline line at the carbureter by unscrewing the brass coupling nut with a pair of pliers or end wrench.

13—Remove the locking wire from the crankcase front-bearing screws and start the screws out with a 7-16-in. open-end wrench, turning them out with a 7-16-in. speed wrench after they are loose enough.

*J—Remove the cotter pins from the four crankcase-arm bolts, two in the side and two in the top.*

*K—Remove the side nuts with a  $\frac{3}{8}$ -in. end wrench.*

*L—Remove the top nuts with a  $\frac{3}{8}$ -in. speed wrench, holding the bolts with an end wrench both here and in operation K.*

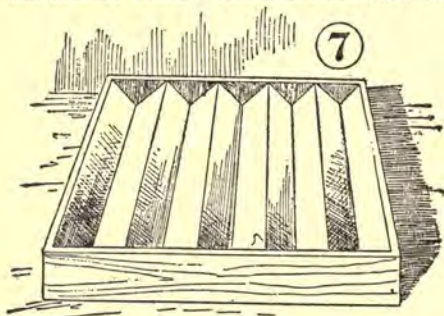
14—Remove the four nuts from the manifold clamp studs with a  $\frac{3}{8}$ -in. speed wrench.

*F—Take off the brass washers.*

The radiator is now ready to be disconnected from the engine.

16—Lift off the intake manifold complete with the carbureter. Slide it straight out and then lift up to avoid spoiling the copper-asbestos gaskets. Hang the gaskets on a nail on the parts box.

17—Lift off the exhaust manifold, pulling the pipe straight ahead out of the muffler head. The manifold does not



*Fig. 7—This is a cottoer-pin box made of wood with V-shaped compartments to hold the different size cottoer pins. One of these boxes is placed in a handy position near every workman who has need for new cottoer pins*

have to be disconnected from the exhaust pipe and the pack nut does not have to be touched. If it should be necessary to

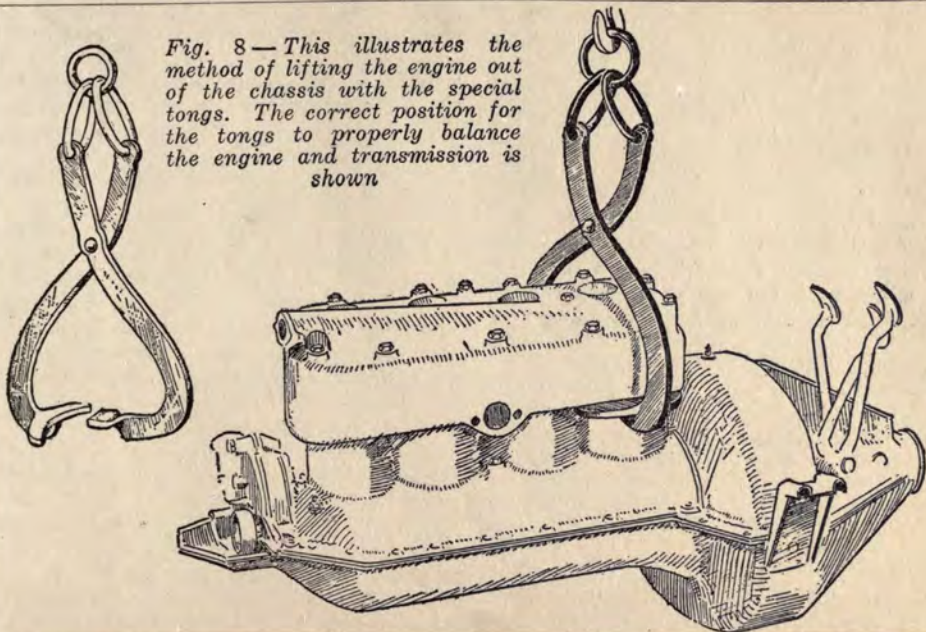
separate the manifold from the pipe, the pack nut is best loosened with a pack nut solid wrench before the clamps are loosened, as these clamps hold the manifold much better than it could be held in a vise and there is no danger of cracking the manifold or denting the pipe.

*M—Remove the cottoer pins from the crankcase bolts.*

18—Loosen those bolts which clamp the engine pans. This is done with a jew wrench or a speeder on the nut and a knee wrench on the head of the bolt underneath. Either of these tools allows the bolts to be loosened or taken out by one man. See operations under "Taking the engine down" for more complete details on this operation.

19—Remove the stove bolts and nuts that hold the engine pans to the frame and then take out the pans. The right pan is to be placed in the parts box, but the left pan cannot be taken off entirely unless the steering-arm connection is taken off, but it can be slid down out of the way and left hanging on the steering arm.

*Fig. 8—This illustrates the method of lifting the engine out of the chassis with the special tongs. The correct position for the tongs to properly balance the engine and transmission is shown*



20—Remove the two bolts, two nuts and two cap screws that hold the universal-joint ball housing to the crankcase, first taking out the locking wire. Use a  $\frac{3}{8}$ -in. end wrench or long speed wrench from the rear of the car.

*N—Take out the two cap screws that hold the front-radius-rod ball cap to the engine.*

This breaks the last connection between the engine and chassis and the engine is now ready to be taken out. But the dash must first be loosened to allow the crankcase arms to come for-

ward. This is done by removing the bolts from the angle irons.

There are several methods of lifting the engine out of the frame, the best one being with a pair of tongs and a chain hoist.

A pair of tongs grips the cylinder block at a point between the third and fourth cylinders. The tongs are hung from a chain hoist or tackle and will grip the engine without danger of falling as the heavier the weight, the harder the tongs grip. This is shown in Fig. 8.

## CHAPTER IV

### Taking Down the Engine

**F**OR rapid work on the engine, both in taking down and in assembling, an engine stand must be used. Just how many and what kind of stands to use will depend largely on the volume of work to be done in the shop. The simplest and cheapest engine stands are constructed of wood and are made in two styles, one holding the engine right side up and the other holding it upside down. These are shown in Figs. 9 and 10. A metal engine stand which is lighter is shown in Fig. 11. These stands are for assembly and taking down only and there is no means of fastening the engine to the stand. These stands should be provided with castors so that the whole assembly can be easily moved about by one man or a helper.

After taking the engine out of the car with the tongs (Fig. 15) and chain hoist, it is set on one of the stands

shown in Figs. 9 or 11, and the work of taking down starts.

1—Drain the oil into a pail by taking out the drain plug. The gasket should be renewed as it is hard to get an old one tight, so this one can be junked. Put the plug back in the hole after the oil is all out and screw it in far enough so that it will not lose.

2—Take all the cotter pins out of the crankcase bolts and transmission case bolts. They are to be junked.

3—Remove the fan shaft bracket by taking out the cotter pin at the back end of the bolt, taking off the locknut and screwing out the long bolt.

4—Take off the fan belt.

5—Remove the timer from the camshaft.

6—Remove the timing gear case by taking out the cap screws.

7—Loosen the reverse, low speed and

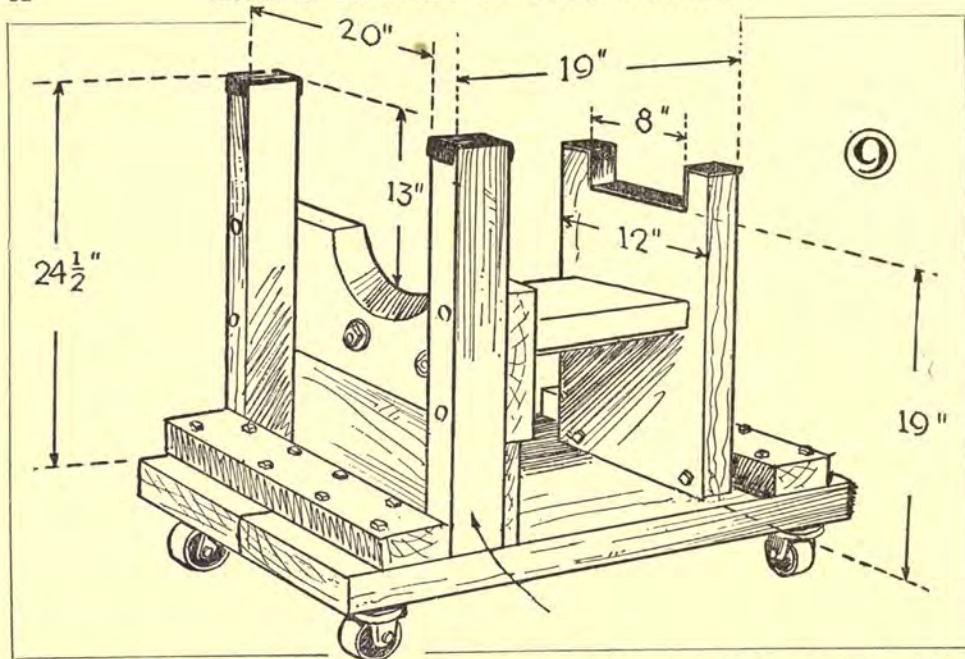


Fig. 9—Wooden engine stand for holding the assembled engine in its natural position



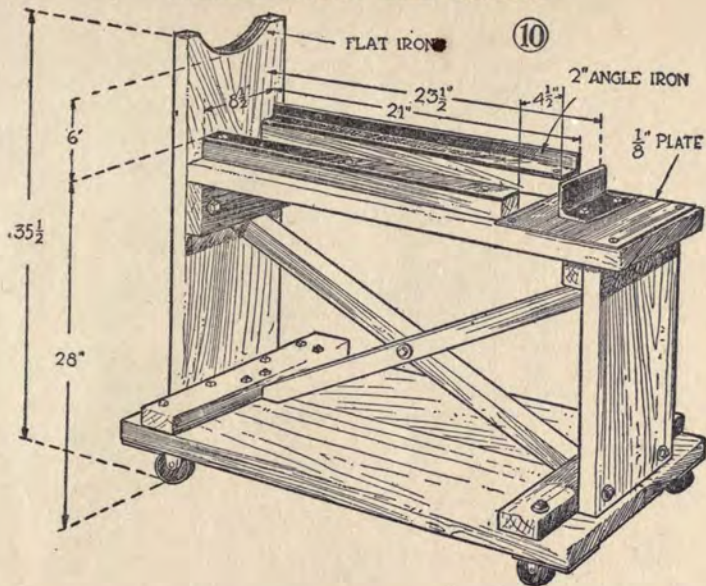
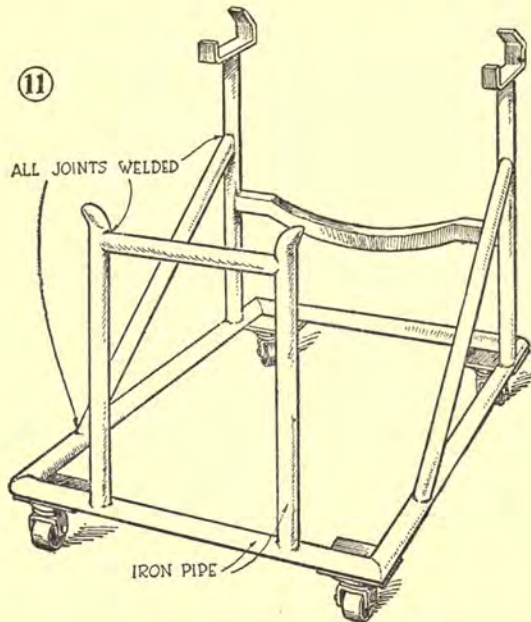


Fig. 10—Wooden engine stand for holding the assembled engine upside down for easy removal of the crankcase and subsequent work on the bearings and connecting rods. The head is removed from the engine before transferring it to this stand



*Fig. 11—A metal engine stand made from iron pipe welded at the joints. It answers the same purpose as the wooden one shown in Fig. 9 but it is lighter in weight*

brake adjustments on the transmission.

8—Hold the boltheads underneath the transmission case with a  $\frac{3}{8}$ -in. open end wrench or a knee wrench and turn the nuts off with a  $\frac{3}{8}$ -in. speed wrench. A jew socket wrench may be used and one is shown in Fig. 14.

9—Remove the transmission cover, the pedals coming off with it.

10—Loosen the cylinder-head bolts with a  $\frac{7}{16}$ -in. end wrench.

11—Turn the bolts out with a  $\frac{7}{16}$ -in. speed wrench.

12—Lift off the cylinder head. If it sticks, it can be started loose by cautiously slipping the point of a screwdriver between the head and the block and turning or prying until the joint loosens. It is then lifted off by catching a finger of each hand in the spark-plug holes of cylinders 1 and 4.

13—Hang the copper-asbestos cylinder-head gasket on a nail if it is in fair shape to be used again, otherwise put it in the junk box.

14—Remove the nuts from the valve-

cover studs with a  $\frac{3}{8}$ -in. speed wrench.

15—Remove the valve covers.

16—Put the nuts back on the studs to prevent their getting lost.

17—Mark the valve heads with a center punch, starting with the front No. 1 to the back No. 8.

18—Raise the valve springs one at a time with the valve lifter and pull out the pins. The pins can best be taken out with a light pair of pliers with long noses. This is quicker and easier than using the fingers.

19—Lift out the valves by the heads.

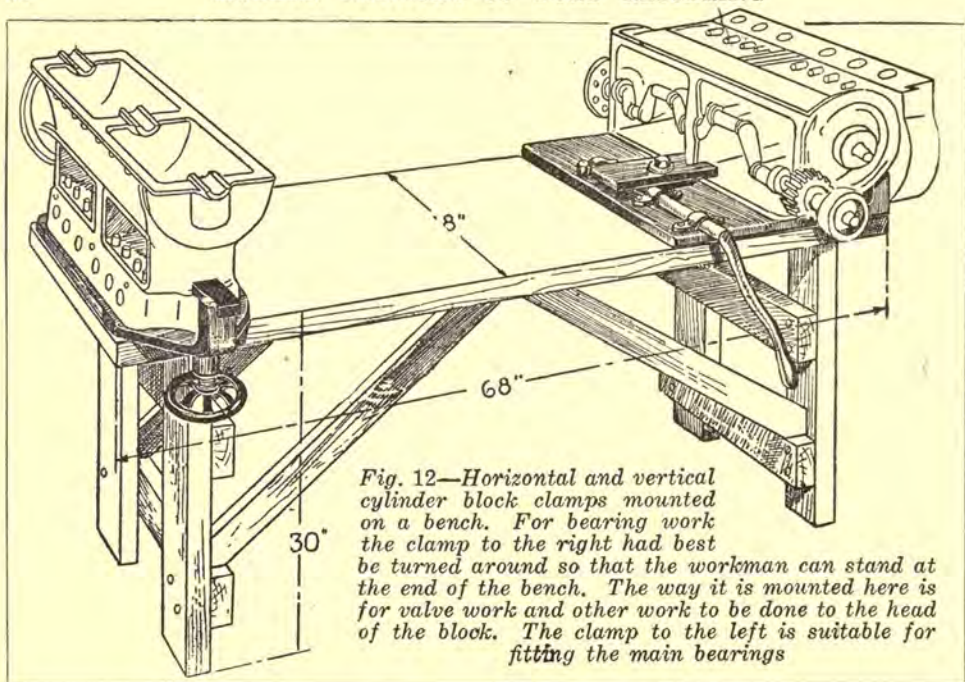
20—Pull out the springs and cup washers.

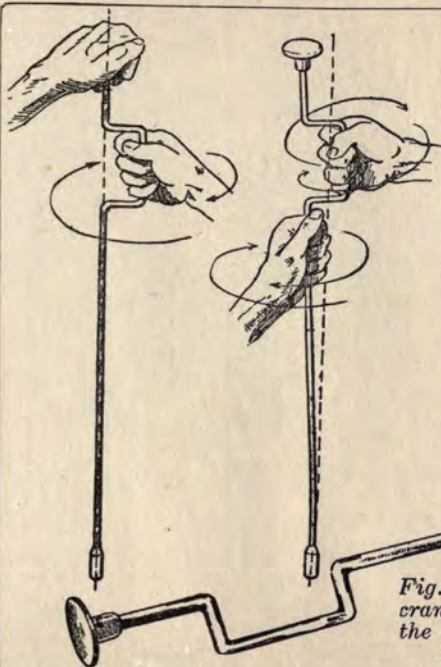
21—Turn the engine upside down and set it on the stand shown in Fig. 10.

22—Hold the crankcase nuts with a  $\frac{3}{8}$ -in. open-end wrench or knee wrench.

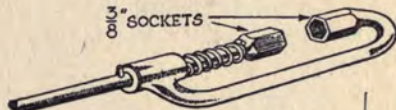
23—Turn out the bolts with a  $\frac{3}{8}$ -in. speed wrench. (See Fig. 13.) The jew socket wrench shown in Fig. 14 may also be used for this purpose.

24—Remove the crankcase.





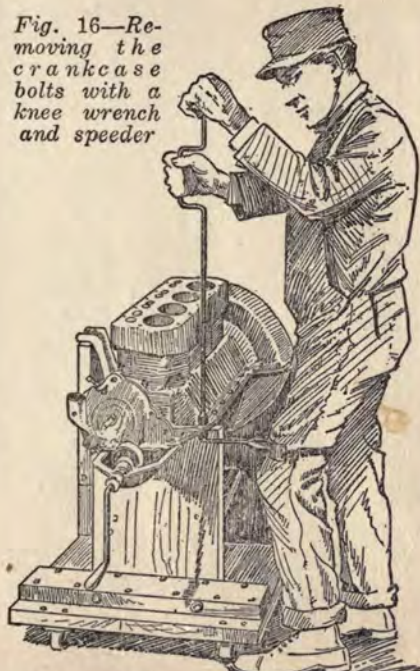
*Fig. 13—In using a speeder of any kind, greater speed can be obtained by holding the right hand on the crank and the left hand just below the crank and making both hands move. This just doubles the speed obtained by holding the right hand on the crank and the left hand on top, because the "stroke" is only half as much*



*Fig. 14—Jew socket wrench for removing the crankcase bolts. This method is even faster than the knee wrench and speeder as the spring holds the lower socket up against the bolt head*



*Fig. 16—Removing the crankcase bolts with a knee wrench and speeder*



30—Lift off the coil assembly.

31—Remove the oil pipe.

32—The engine block, now containing the crankshaft, connecting rods, pistons and camshaft, is washed with kerosene to remove all the oil and dirt.

33—Place the block in a stand shown in Fig. 17.

34—Turn the block in the stand so that the cylinders are horizontal, then latch the stand in this position.

35—Remove the  $\frac{3}{8}$ -in. cap screws that keep the camshaft bearings from turning.

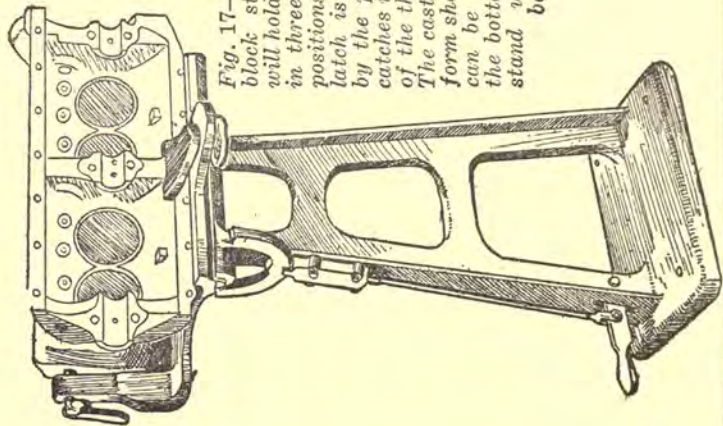
36—Remove the timer roller locknut and roller.

37—Pull the camshaft out through the front of the engine in one unit with the gear-wheel.

38—Mark the pistons on top with a center punch, 1, 2, 3 and 4.

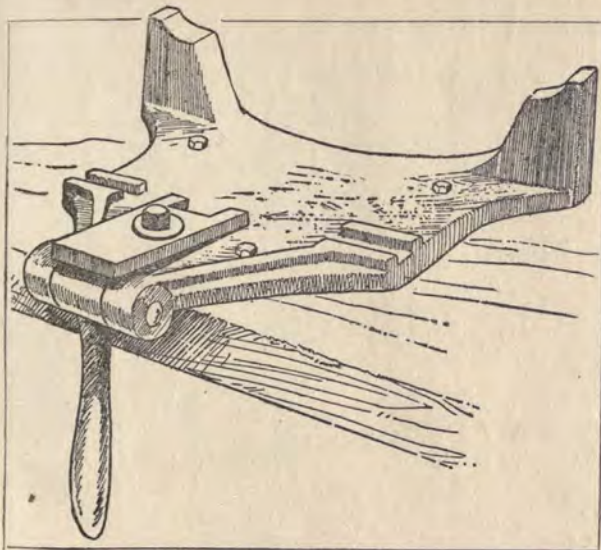
39—Mark the main-bearing caps in the same way at the front ends, 1, 2 and 3.

40—Mark the connecting-rod bearing caps on



*Fig. 17—Cylinder block stand that will hold the block in three different positions. The latch is operated by the pedal and catches in any one of the three slots. The castored platform shown above can be bolted to the bottom of the stand with four bolts*





*Fig. 18—Cylinder block stand for bolting to the bench. This holds the block in a horizontal position for work on the bearings, pistons, etc. The handle operates an eccentric cam which locks the block to the stand*

41—Remove the cotters from the connecting-rod bolts.

42—Remove the connecting-rod bolts, starting them with an L-wrench and turning them out with a speeder.

43—Reassemble the caps to the rods with the bolts.

44—Push the pistons out through the top of the cylinder block.

45—Lay the pistons on the bench on their heads.

46—Remove the cotter pins from the main-bearing bolts.

47—Hold the heads of the main-bearing bolts from turning while the nuts are taken off. These front and center bolt heads are square, and the rear heads are round with one side milled off. The nuts are hexagon. Use speeders on the lower ends.

48—Lift out the crankshaft.

There is no better place to practice economy than in tearing down the engine where nearly all the work can be done by boys or helpers. They can soon be taught to use the speeders and can take nuts off quite as quickly as more experienced and higher priced men. This leaves the better grade mechanics available for work that requires more judgment and skill.

Routing and dividing the work spells success or failure and it is often possible for one good mechanic to superintend the work of several helpers and at the same time list and tag the parts of the different engines so that the new parts can be ordered from stock. Every minute lost is expense added to the jobs and the more time is lost, the higher the job will come.

## CHAPTER V

### Testing and Straightening the Crankshaft

**B**EFORE fitting the main and connecting-rod bearings to the crankshaft it is necessary to test the crankshaft to find out whether the shaft is bent or sprung. No matter how carefully or how well the bearings are fitted, if the crankshaft is out of line, it is only a matter of time when the same old bearing trouble will appear and the more the shaft is out of line the quicker the bearings will go.

For straightening and testing, a combination tool shown in Fig. 19 is used. This tool has a bar in front to which are fitted two sliding centers.

1—Place the crankshaft between these centers, sliding one or the other to the shaft till it is held firmly.

2—A multiplying indicator (see Fig. 19A) is placed with the base on the block of the press and the plunger of the

indicator resting lightly on the center bearing of the shaft.

3—Turn the shaft around slowly, keeping your eye on the needle. A variation of .002 in. is permissible, but more than this indicates that the shaft needs straightening. The high side of the shaft is marked with a piece of chalk.

4—A bent shaft is straightened in a straightening press which forms the rear part of the tool shown in Fig. 19. The shaft is laid across the two lugs with the chalked or high side up.

5—Pressure is applied to this point by setting down on the screw and the shaft is tested again.

6—This operation is repeated until the needle of the indicator shows a variation of not more than .002 in.

7—A shaft that is much out of line should be tested also on the two end

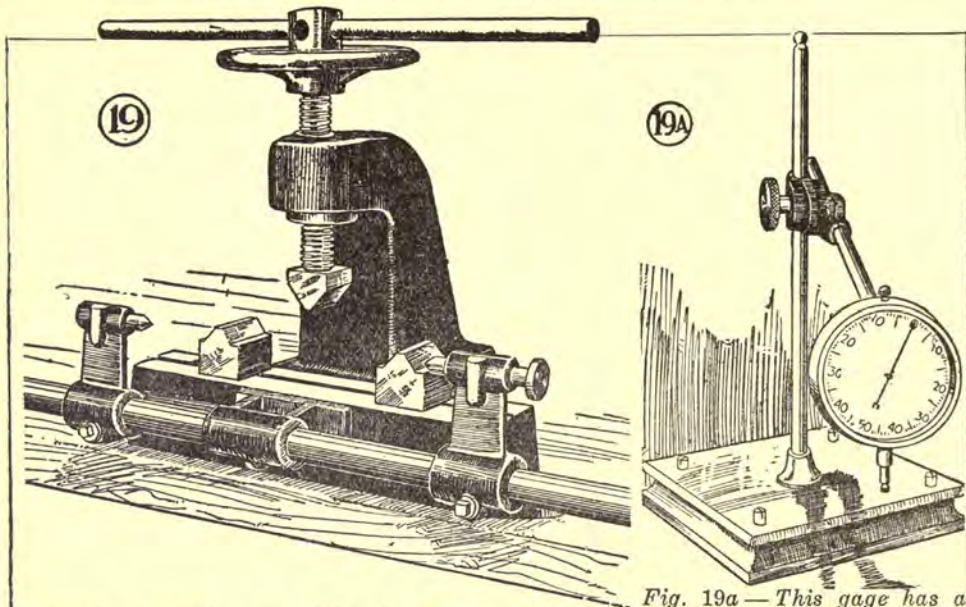


Fig. 19—Crankshaft straightening press and testing machine. The shaft is caught between the centers and

Fig. 19a—This gage has a plunger that records any up and down motion on the dial, which can be set to zero.

bearings after straightening as there is a possibility of throwing these out of line when bringing the center bearing in line.

8—A shaft that shows true on the center bearing before straightening will be true on the end bearing.

9—If the main bearing surfaces are true, the crankpins are bound to be true. Even a new shaft from stock should be tested for alignment as there is a possibility of its having received rough usage at some point in its travels from the factory to you.

## CHAPTER VI

### Rebabbitting the Cylinder Block

**I**F the babbitt in the cylinder block is loose or much worn, the block will have to be rebabbitted. This may be done by sending the block to the nearest Ford branch or it can be done with a babbitt-ing jig as follows:

1—Hold the block on the engine stand so that it is bottom side up and the cylinders as nearly perpendicular as possible.

2—Cut out the old babbitt metal, taking care to clean out the holes which key the babbitt to the block and also the oil holes.

3—Clamp the babbitting jig (Fig. 20) in position with the camshaft centering pins in the camshaft bearings. This gives the correct gear distance between the camshaft and the crankshaft so that the gears will mesh properly.

4—Turn the eccentric locks up against the bearings to prevent leakage of babbitt.

5—Melt the babbitt in a ladle. To produce a satisfactory bearing, use the best grade of babbitt, melting about 5 lb. in a 10-lb. ladle.

6—It should be heated till it scorches a pine stick but does not set it on fire. If it sets it on fire, it is too hot, the metal has been burned and should be discarded.

7—Stir the metal with the stick and skim off the dross.

8—Pour the metal quickly but steadily into the molds.

9—Needless to say the molds should be absolutely clean, dry and free from oil and grease. A trace of moisture would be turned to steam by the hot metal and this would forcibly expel the molten metal, necessitating the removal of the jig, cleaning the bits of metal and starting all over again, not to mention the possibility of injury to the operator. This cannot happen in a perfectly dry mold. Oil or grease may cause some-

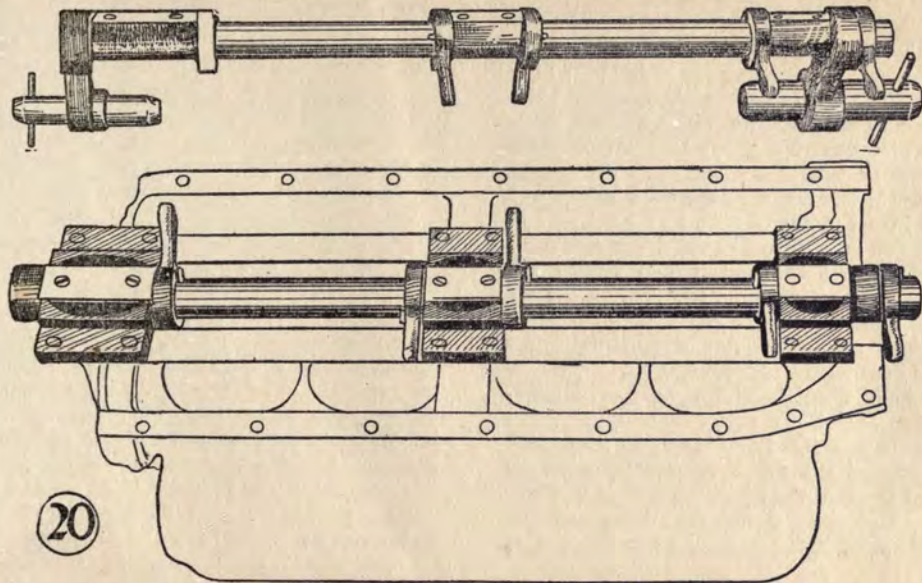


Fig. 20—The rebabbitting jig set in position on the block. The correct distance between the camshaft and crankshaft is secured by the lugs which fit into the camshaft bearings

what the same trouble and make blow holes in the bearing. It is best to pre-heat the portion of the block around the bearings with a blow torch or gas torch and also heat the jig as this will make a smoother job.

10—If the metal is too cold, it will not get into the corners of the mold and it will not hug closely around the shaft.

11—After the metal has cooled off enough to set, remove the jig and file off any fins that have been formed. The babbitt should be flat across with the iron seat that the cap rests on.

12—If the babbitt has been well done, the metal at the right temperature, the casting preheated and it flows up smoothly around the shaft there should be no need to ream the bearings before burning in. However, a more satisfactory job will result if the bearings are reamed or

bored with a special jig or reamer, of which there are several excellent makes on the market.

13—Rough scrape the bearings to fit the crankshaft endwise, being careful not to remove too much metal. There must be no endplay to the crankshaft.

14—The bearings are now ready to burn in.

If no other operations are necessary, the preparations for burning-in can be started at once, but if the cylinders are to be rebored, the reboring should be completed before the bearing work is started because it is not necessary to disassemble the bearings after they have been burned in. The overhauling and assembly of the pistons should also be completed before starting to burn in the bearings. In other words, the burning-in goes along with the assembly operation.



## CHAPTER VII

### Reboring the Cylinders

**C**YLINDERS can be rebored by a number of different methods. The quickest way is by the use of a boring mill which is specially set or specially constructed for the Ford engine. Such a machine is quite expensive, however, and only the larger service stations would find it profitable to own and operate one. \*

There are several very excellent smaller tools on the market at the present time which are really greatly modified reamers especially designed for the purpose of boring out cylinders. These operate by clamping a guide to the top of the cylinder block. Through this guide extends the shaft which has a cutter head on the lower end. The cutters are adjustable so that the cylinder can be bored to fit the standard oversize pistons and the cutter head is fed by a screw on the shaft which turns in a nut or threaded hole in the clamp. Some of the types

are shown in Fig. 21. No specific instructions can be given for operating the tools as they vary in mechanical design. The following operations cover the use of any one of the tools:

1—Examine the bore of each cylinder carefully to decide how much oversize the bore will have to be. The standards are:

No. 3021 (piston)  $3\frac{3}{4}$  in. diameter  
(standard size)

No. 3021-C (piston) .0025 in. oversize

No. 3021-D (piston) .03125 in. oversize

No. 3021-E (piston) .033 in. oversize

The bore should be measured at a number of different places with an inside micrometer and the cylinder bored to the next largest standard oversize unless there are scores and scratches, in which case the sizes will be larger still. The method of using the inside micrometer for this purpose is shown in Fig. 22. If the block has already been rebored to the

largest oversize, it will have to be discarded and replaced by a new one, as there is a chance of running into a blow hole or getting the metal of the cylinder

wall too thin at places and not only this, but it would be necessary to make up special pistons and rings which would

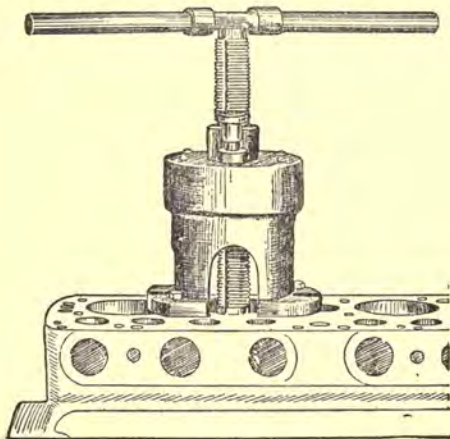


Fig. 21-A

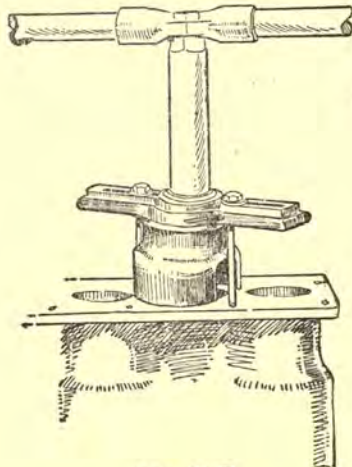


Fig. 21-B

*Fig. 21—There are a number of types of cylinder boring tools, two of which are shown here and one on the next page*

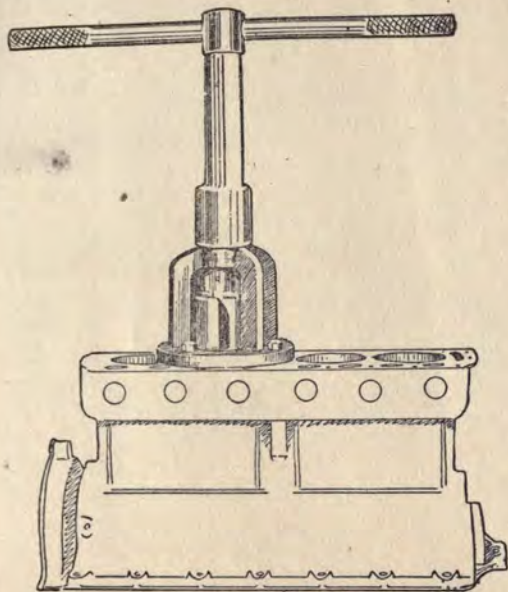


Fig. 21-C—Another type of reboring tool.

most likely cost more than the fitting of a new block.

2—Set the cutters on the boring tool to the exact oversize desired, using an outside micrometer. The method is illustrated in Fig. 23.

3—Clean off the top of the cylinder block, scraping off all the dirt and pieces of gasket with a putty knife. This will allow the clamp to sit down true and flat on the block so that the cutters will cut a surface exactly at right angles to the top of the cylinder block. Theoretically the clamp does not actually guide the direction of the cutters, but any side thrust caused by the clamp not being set down true is bound to cause more pressure on one side than the other. Therefore it is best to have the clamp true.

4—Clean out the cylinder bore, removing all oil, grease and dirt.

5—Clamp the cylinder block firmly in place in such a position that the workman will find it convenient and easy to turn the handle. It is generally found

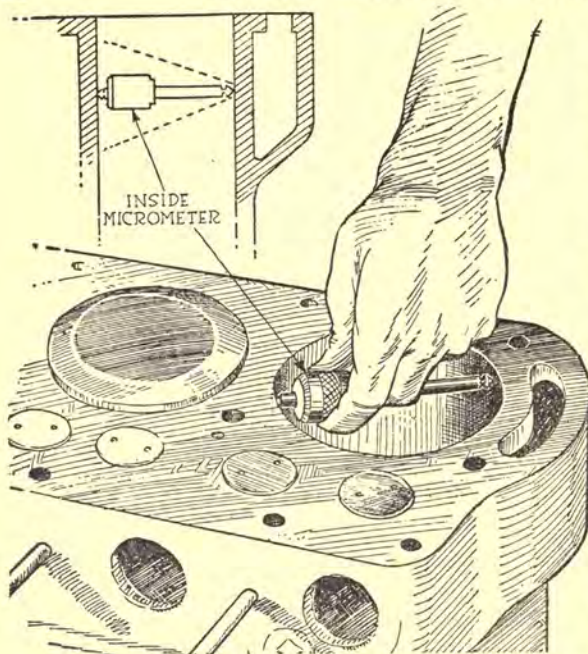


Fig. 22—Measuring the bore with a micrometer

convenient to have some means of clamping the block directly on the floor or on a stand a few inches high. This enables the workman to stand in an upright position.

6—Put the clamp in place. On some boring tools the cutter centers itself in the cylinder bore by means of a lead ring. In such a case it is only necessary to insert the lead ring in the cylinder and then bolt the clamp fast to the top of the block. Other makes require centering by hand and this must be done very carefully to insure a true bore.

7—Set all the clamp bolts down good and tight and be sure that they are all equally set. One or two loose bolts may throw the clamp out of line or allow it to slip, which would be fatal to a true bore.

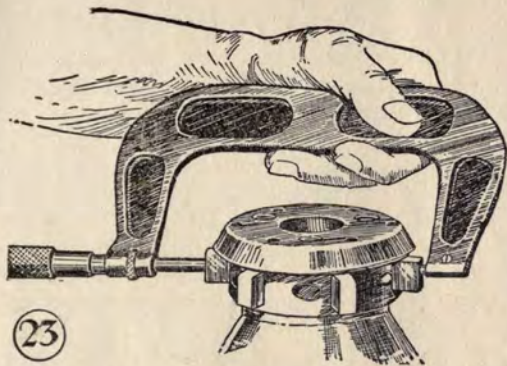


Fig. 23—Setting the cutters with an outside micrometer

8—Turn the handle of the bar which rotates the cutters and also feeds the cutters into the cylinder. The cutters should be fed clear through the cylinder.

9—Repeat the operation on the other cylinders.

10—Remove all the chips and cuttings, first by blowing out with compressed air, then by washing with gasoline or kerosene.

If the cylinders are not scored and are very little out of round, they may be lapped true, as described in Chapter VIII. As a rule, however, it is cheaper and quicker to rebores and fit new pistons and rings than to lap.

## CHAPTER VIII

### Fitting New Pistons

**I**F the cylinders have been rebored, the new oversize pistons should fit into the cylinders very closely but should not stick. Ordinarily lapping is not resorted to in Ford work because the pistons are very accurately sized and if the cylinder reboring has been accurately done, there is no need for it. It simply adds to the expense of the overhaul operation without any appreciable benefit. In extreme cases where the bore is not quite up to size or where oversize pistons are to be fitted to old cylinders without reboring, the pistons may be lapped in if they fit too closely. In any case an extra charge should be made for lapping, over and above the regular charges, otherwise a loss may be sustained on the operation. This is the procedure if lapping is deemed necessary:

1—Take a Ford piston which is larger than the diameter of the cylinder to be lapped and turn down the head to the



*Fig. 24—An old piston slit to make a cylinder lap*

diameter of the cylinder, leaving the skirt full size. See Fig. 24.

2—Slit the skirt diagonally with a hack saw.

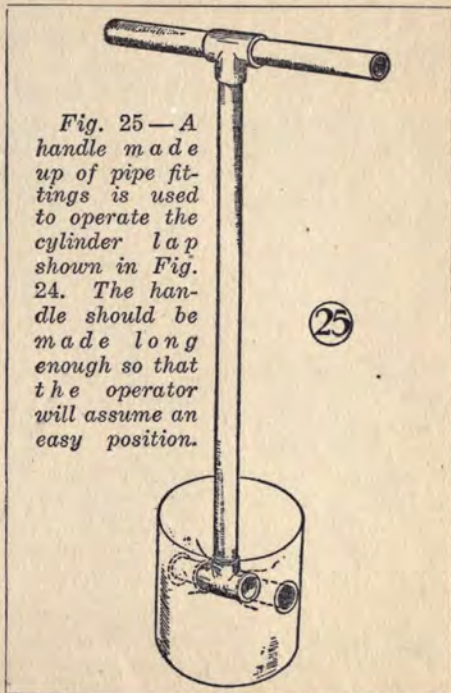
3—Make a handle of 1-in. iron pipe and fittings as shown in Fig. 25.

4—Smear the lap with a small amount of fine grinding compound. It is not necessary to use a large amount and an excess will simply be wasted and will run down the walls, getting over everything.

5—The proper lapping motion is a combined twist and up-and-down stroke throughout the entire length of the cylinder. The lap should be turned from time to time to bring new surfaces into contact.

6—When the cylinder has been lapped so that the new piston will enter the cylinder and slide clear through without binding, the lapping is finished.

7—Coat the new piston with a mixture of ground glass and oil and transfer the lapping handle from the slit piston to the new one.



*Fig. 25 — A handle made up of pipe fittings is used to operate the cylinder lap shown in Fig. 24. The handle should be made long enough so that the operator will assume an easy position.*

8—Lap each piston into the cylinder which it is to occupy.

9—The lapping should be continued until the piston when dry and clean may be easily moved through the entire length of the stroke. It should not bind when moved around.

10—The clearance between pistons and cylinders should be between .003 and .004 in. for cast iron pistons. Alloy pistons require about twice this clearance.

If the difference in size is not too great it is not necessary to use the slit piston and the new piston can be lapped right in.

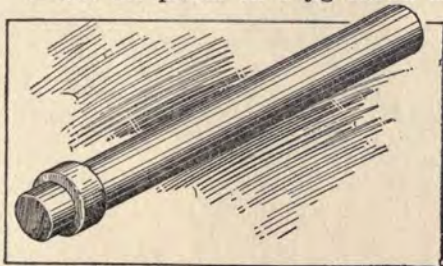


## CHAPTER IX

### Fitting the Piston Pin

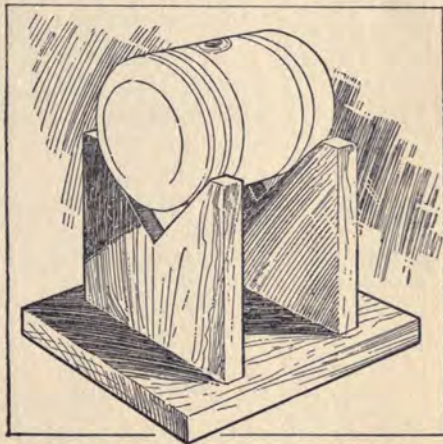
**I**F there is lost motion between the piston pin and the bronze bushings in the piston bosses, the bushings, or perhaps both bushings and pin will have to be renewed. If the pin is worn, the wear can be easily seen or it can be determined with a micrometer.

1—Set the piston on a jig shown in



*Fig. 27—This piston-pin bushing driver is turned out of a solid piece of steel.*

Fig. 26, while driving the bushings out.  
2—Drive out the bushings with a tool



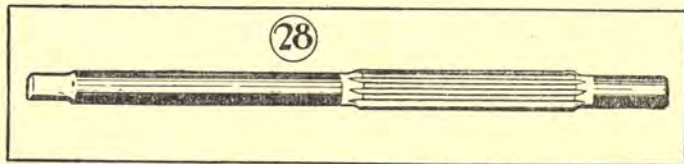
*Fig. 26—This stand holds the piston while the bushings are driven out.*

shown in Fig. 27. This is made with the shaft a little less in diameter than the diameter of the piston pin and the diameter of the collar a trifle less than the outside diameter of the bushing. It is

similar tool and jig can be advantageously used.

4—Drive in the new bushings with the same tool and jig.

5—Ream the bushings to the correct



*Fig. 28—The piston-pin bushing reamer*

preferable that the whole tool be made in one piece, turned down to size.

3—If an arbor press is available, a

size with the piston bushing reamer shown in Fig. 28.

## CHAPTER X

### Aligning the Connecting Rod

**T**HE two holes in the connecting rod must be parallel both ways to insure perfect operation of the engine. Twisted rods cause a great deal of trouble,

ing and straightening jig used and recommended by the Ford Motor Co. is shown in Fig. 31. This jig is bolted to the bench on a block so that it is about

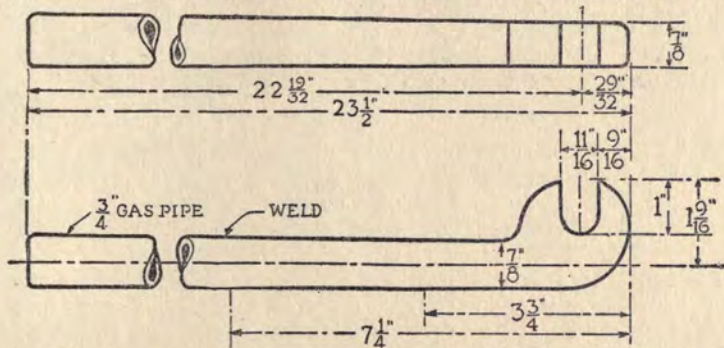


Fig. 29—Detailed drawing of the connecting-rod bending tool

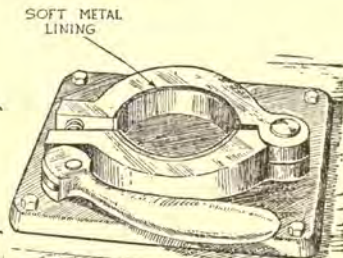
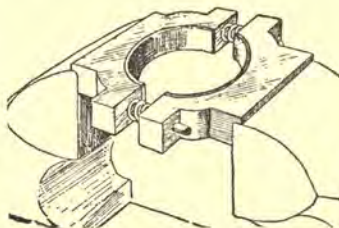
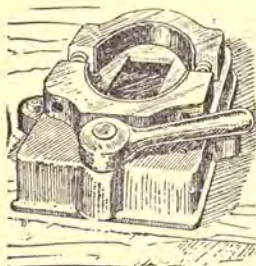
rapid wear and noisy engines. All rods, new and old, should be tested before assembling the rod in the piston. A test-

on a level with the workman's eye.

1—Put the larger of the two arbors through one side of the frame of the jig.

2—Slack the connecting-rod bolts a trifle to allow the arbor to go through the bearing.

3—Slide the arbor through the bearing



*Fig. 30—Three types of piston vise, two to be attached to the bench and one to be used in a regular vise*

and through the other side of the jig frame.

4—Tighten the bolts.

5—Clamp the small arbor in the upper hole with the small clamp.

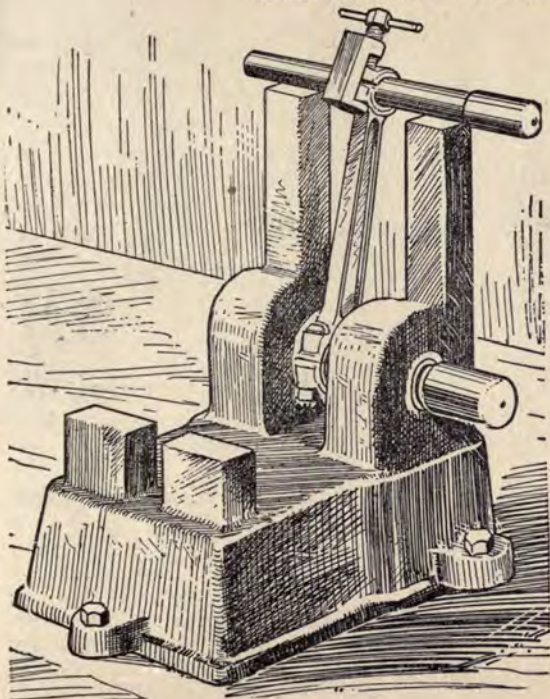
6—Rest the small arbor first against the top test surface to test for parallelism, then against the lower set to test

for twist. If light can be seen under one side in either case, the rod must be bent until the small arbor rests evenly down on all four test surfaces.

7—The bending is done with the bending iron shown in Fig. 29.

8—The connecting rod is now assembled to the piston with the piston pin.

9—The piston is clamped in a special piston vise to prevent injury to the surface of the piston. Three types are shown in Fig. 30. Two of these are in-



tended to be fastened to the bench with a hole for the connecting rod to drop through when the piston is clamped right side up for working on the piston rings, and the other type fits in a regular machinist's vise. The faces are lined with babbitt or soft metal to prevent injury to the piston or rings.

10—Push the piston pin through the bushings and upper hole in the connecting rod.

11—Center the piston pin so that it will not extend to the outside of the piston when the rod is slid sidewise to touch either boss.

12—Tighten the piston-pin clamp screw.

13—Insert and spread the cotter pin.

---

*Fig. 31—The connecting-rod alignment jig is set on a line with the workman's eye*

After the rods have been straightened, the utmost care should be used not to bend them again. The bolts must not be tightened when the rod is held in a regular vise.

The connecting rod should swing freely in the piston but should not have any lost motion up-and-down. It is very easy to confuse side motion with up-and-down

motion, especially if the piston pin is well oiled. The connecting rod should be grasped firmly in the hand to make the

Rebabbiting connecting rods has not been largely practiced so far unless the shop is a very large one or is out of close touch with a Ford branch, but there are several excellent jigs on the market at the present time.

## CHAPTER XI

### Fitting the Piston Rings on New and Old Pistons

**P**ISTON rings can be slipped on and off the pistons by using any one of a variety of methods, but the piston ring expander shown in Fig. 32 is the quickest and easiest to operate. If the piston is new:

1—Fit each ring to the groove and to the cylinder that it is to occupy. Fig. 33 shows the method of fitting the rings to the pistons. Work the ring around the groove. It should fit freely all the way round.

2—If there are any high spots, they are removed by rubbing the ring on a piece of emery cloth mounted on a flat board as shown in Fig. 34 or on a surface plate with grinding compound on it. The fit should be free but not too free. The rings must not be mixed after fitting.

Note—All rings now made by the Ford Motor Co. are slightly tapered on the outside to prevent pumping oil up

into the combustion chamber. The small diameter goes to the top. The edge with the smaller diameter is marked on the inside by a light cold chisel mark as shown in Fig. 35. *This chisel mark must go to the top of the piston.*

3—The ends of the rings are now filed down so that the rings will fit into the cylinder.

4—A piston without rings is placed in the cylinder.

5—Push one ring down above it.

6—Raise the piston to square the ring in the cylinder.

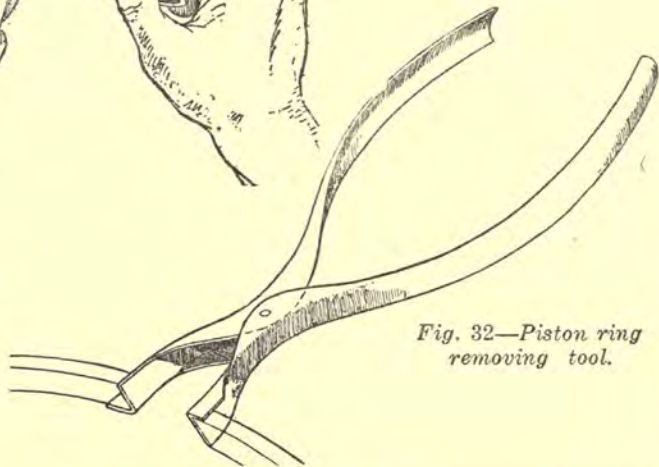
7—File the end of the ring till the clearance between the ends is about .004 in. or a little more than the thickness of the paper that this is printed on.

8—Assemble the rings on the pistons *with the chisel mark up.*

9—Where old pistons are used, the ring grooves are first cleaned out, re-



*Fig. 33—Fitting the rings to the piston.*



*Fig. 32—Piston ring removing tool.*



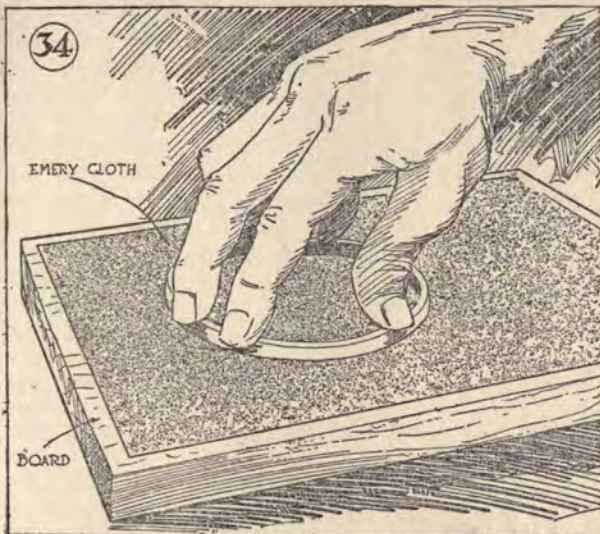


Fig. 34—Grinding down the ring edges.

moving all accumulations of carbon. A quick and easy way to do this is with a tool shown in Fig. 36. This can be made

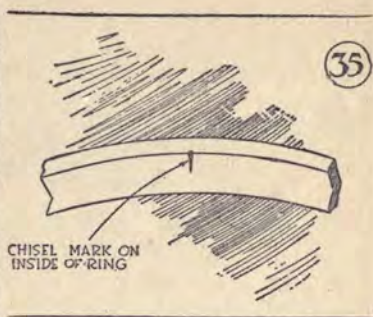
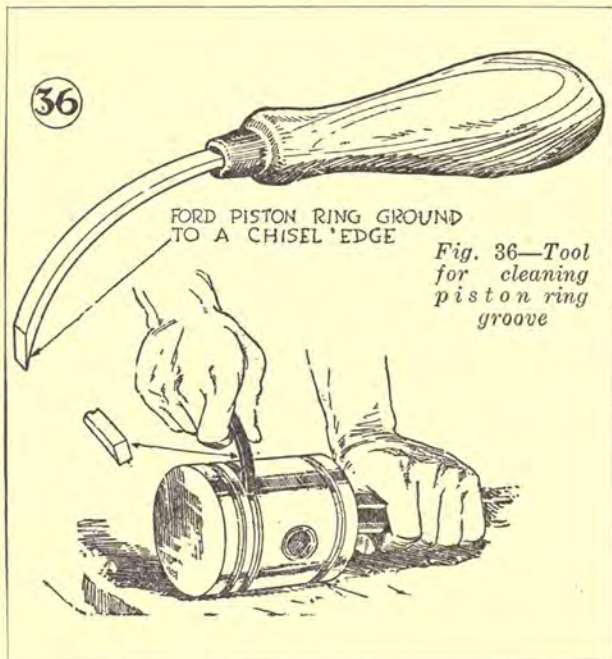


Fig. 35—This chisel mark on the piston ring goes to the top

from an old piston ring or can be forged from tool steel so that it will retain its edge longer.

10—New rings are fitted the same as in the case of a new piston.

In using such a tool or any other means of cleaning out the piston grooves, it is very essential that the sides of the grooves be kept unscratched because



every scratch or cut will allow a little of the compression to leak in back and around the ring. The tool shown, if made of cast iron, the same as the piston material, is less likely to damage the piston than a tool made of hardened steel such as a file or screwdriver. It is also very important that the carbon be removed from the corners of the grooves. It is useless to remove the carbon from the center and then leave it in the corners, because this will prevent the freedom of movement of the piston ring which is so necessary to secure good piston ring action. Carbon on the back of the ring should also be removed and the same care should be taken not to scratch the sides of the ring.

The foregoing method treats of the individual fitting of rings. Standard rings are also put out in the same standard oversizes as the pistons so that it is not necessary to file the ends of the rings at all. Where the cylinder is rebored to a standard oversize and a new oversize

piston fitted, the same oversize rings can be used, this saving a great deal of time in fitting and also insuring an accurate fit at the ends.

Of course when a piston is lapped in to an odd size, it is absolutely necessary to file the ring ends to fit.

## CHAPTER XII

### Burning in the Bearings

**T**HE operation of burning in the bearings on the Ford consists essentially in setting up the caps very tight and running the shaft in the bearings without oil or lubricant of any kind. After running this way for a few minutes, the friction of the shaft against the bearing melts the skin of the babbitt next to the shaft and the babbitt forms itself into a perfect fit around the shaft without further manipulation. Here is a comparison of the time and money expended in fitting bearings by burning them in and scraping them in by hand.

#### Burning-in:

Time (including fitting caps, putting on machine, taking off, putting in piston, etc) .....1½ hr.  
Bearing surface secured .....90-95%

#### Hand scraping:

Time (including fitting caps, putting

in pistons, etc.) .....7-10 hr.  
Bearing surface secured .....40-60%

Almost twice as good a job is produced at a saving of from 5 to 8 hr. on each job and a saving in money of from \$3 to \$6 in operator's time.

The main and connecting-rod bearings are burned in separately and in order that there shall be no delay at the machine, the pistons, connecting rods, rings and piston pins should first have been overhauled in accordance with instructions given in previous chapters of this article, so that they are ready to be assembled into the cylinders as soon as the main bearings have been burned-in. It is not necessary to take the bearing caps off after the bearings are burned-in, consequently this much of the assembly is complete.

There are two types of burning-in machines made at present, one of these

being so designed that the cylinder block is held right side up and the other holding the block up side down. There is no special advantage in either design over the other, except that where the block is held up side down, the bearings, caps and shaft are in plain sight and the progress of the operation can be watched with more facility.

### Set-Up of the Machine

It is desirable that the burning-in machine be set up on as firm a foundation as possible. Lag screws of sufficient length to hold it firmly in place must be used, but if it is possible to bolt through the floor, this is better still.

The power required to run a burning-in machine is not so great after the first 30 seconds of starting, but the first pull is pretty great and an electric motor of at least 10 hp. is desirable. A smaller motor can be used if it is not considered possible to use the bigger one, but the caps may have to be fitted a little looser, the actual time of the burning-in will be

different and it is not possible to get as satisfactory a job.

The proper speed for the machine is 250 r.p.m. This gives the best uniform results. The lowest speed at which it is possible to get any kind of results is 200 r.p.m., and the speed should certainly not exceed 300 r.p.m.

The usual speed of electric motors is between 1200 and 1800 r.p.m., and this will have to be reduced by means of pulleys of different sizes from the shafts.

The best general arrangement if the burning-in machine is the only power-driven unit in the shop is to belt the motor to an overhead shaft and then belt from this shaft to the burning-in machine. If other power machines are already in operation the burning-in machine may be driven from an additional pulley on this shaft. The usual speed of line shafts is about 300 r.p.m.

To calculate the correct diameter of pulleys to produce certain speeds multi-



*Fig. 37—Both the main bearing and connecting-rod caps are taken down on emery cloth*

ply the diameter of the driving pulley by the speed of that pulley, then divide by the speed of the driven pulleys, the answer being the correct diameter for the driven pulley. For example:

Electric motor pulley  
10 in. diameter, speed  
1200 r.p.m.

Required to belt this  
to a line shaft to give  
300 r.p.m. and then to  
a burning-in machine  
with 18 in. pulley the  
speed to be 250 r.p.m.

Multiply the diameter  
of the electric motor  
pulley (10 in.) by the  
speed (1200 r.p.m.),  
which gives 12,000. Di-  
vide this by the speed  
that the line shaft is to

run (300 r.p.m.), gives us 40, which is the diameter the pulley on the line shaft should be.

Another belt goes from the line shaft to the burning-in machine from another pulley. Multiplying the diameter of the machine pulley (18 in.) by the speed it is designed to run (250 r.p.m.), gives us 4500, which divided by the speed of the line shaft (300 r.p.m.), gives an answer of 15, which is the proper diameter of the line shaft pulley.

1—Fit the main bearing caps to the shaft so that when they are held in place with the hand, the ends of the bearing

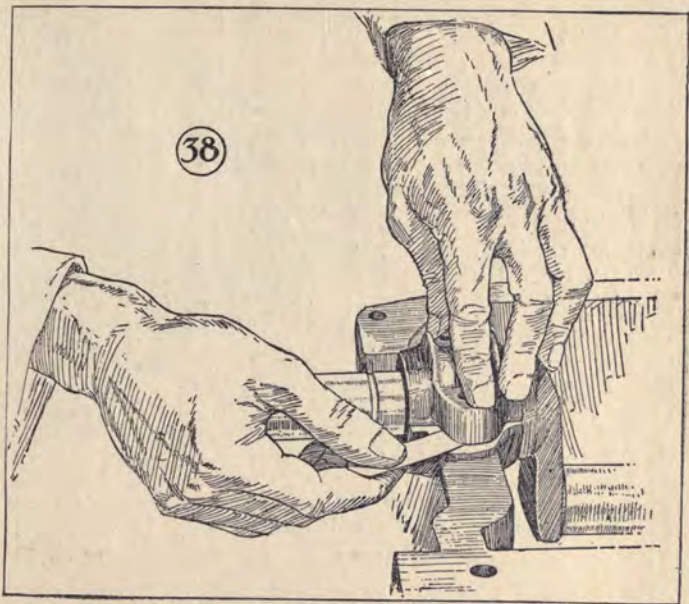
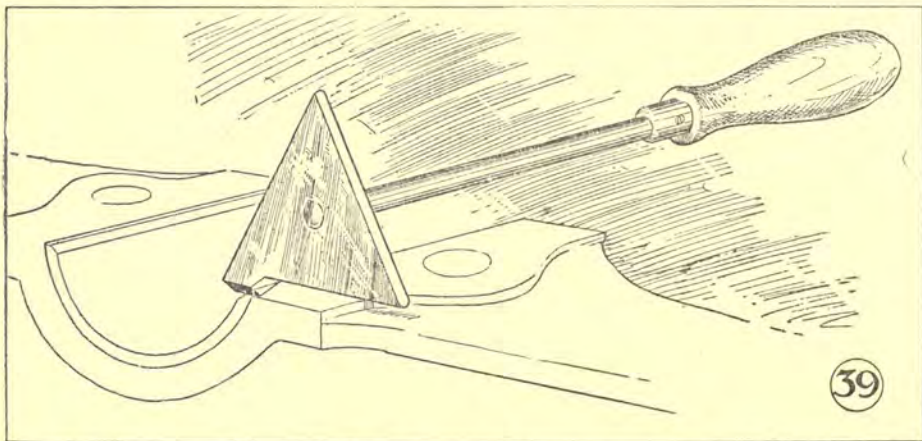


Fig. 38—The rock of the caps should be tested with a feeler gage or piece of shim steel.

where the bolts go through the holes will rock slightly. In other words, the bearing must be a little too tight to set down tight by hand against the liners. If the adjustment cannot be made very exact by shifting the liners around, then the

bearing cap should be taken down a little until the proper "rock" to the cap is obtained. The proper rock is between .004 and .006 in. The paper that this is printed on is .0025 in. thick by micrometer measurement, so the rock



*Fig. 39—Time can be saved in beveling the babbitt by making a special scraper which cuts the edges down very quickly*



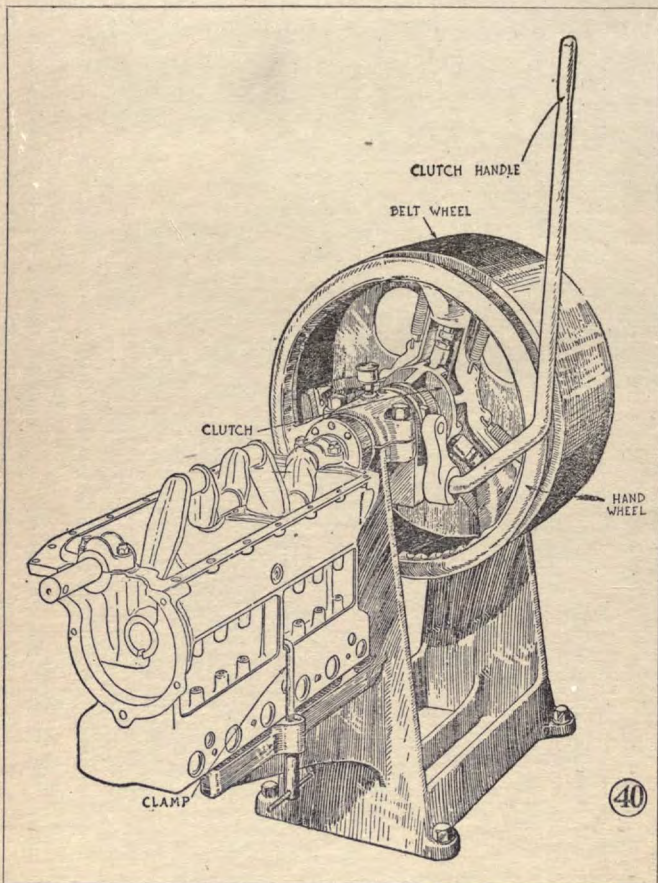


Fig. 40—This is one type of burning-in machine. In this case the block is turned upside down and is clamped in place with two quick-acting clamps

should be about twice the thickness of the paper. A feeler gage can be purchased the correct thickness or can be made up out of shim stock. The method of testing the rock is shown in Fig. 38. A rock of .0025 in. on each side would give a rock of .005 in. on one side when the other side is held down to the block.

2—When taking down bearing caps, they should not be filed as it is a very pretty job to file the caps so that they are not skewed or twisted. A much more accurate method is to take them down on a sheet of emery cloth tacked down to a flat board or over a sheet of glass. By using the method shown in Fig. 37, the caps can be taken down evenly and the faces will be true and flat. If much is to be taken off, a coarse grade may be used to get quicker action. Another plan is to get an emery or carborundum block and use it in the same way as the emery cloth. The block must be trued up occasionally, however, to insure its remaining flat.

3—Remove all traces of emery or grinding compound by washing thor-

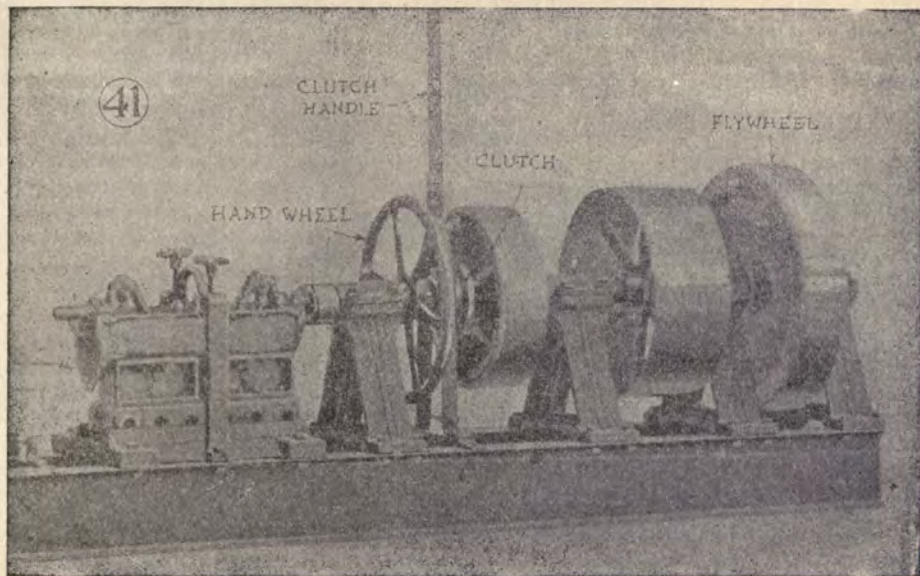
oughly in gasoline.

4—The babbitt in the blocks must be beveled off to allow for the surplus metal which is burned off in the burning-in process. This can be taken out with a file or a special scraper may be made on the plan shown in Fig. 39. This is simply an ordinary painter's scraper with part of one side ground off and a cutting edge formed on the 45 deg. angle formed between the two parts of the blade. The caps do not need to be beveled out as they already have a little clearance in the babbitt.

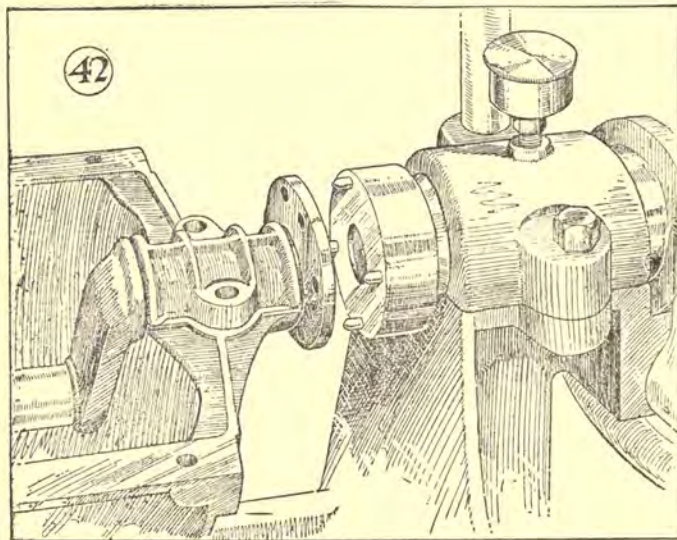
5—Place the block in position on the machine, engaging the lugs of the driving head in the holes in the flywheel flange. The details of the parts are shown in Fig. 42.

6—Clamp the block firmly to the bed with the clamps which will be either on top of the block or at the sides.

7—There is a hand wheel between the clutch of the machine and the block and it should not be possible to turn this by hand if the proper amount of rock has been given to the caps.



*Fig. 41—This is another type burning-in machine. A flywheel is added to the shaft and it differs in some other respects from the one shown in Fig. 40, but the principle remains the same*



*Fig. 42 — Details of the driving head of the burning-in machine. The lugs engage the holes in the flywheel flange*

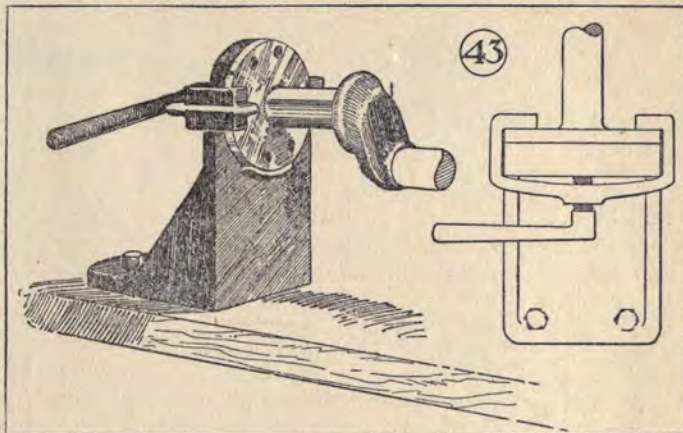
8—Throw in the clutch slowly. If the bearings are so tight that the belt slips or the motor slows down, slip the clutch in and out two or three times till things loosen up so that the machinery will take the load.

9—Have a watch or clock handy and time the running of the machine for the time that the clutch is in. After the machine has run about 30 seconds, feel the three bearing caps with the finger, being careful not to get mixed up with the revolving cranks. The caps should be smoking hot by this time and should not bear the touch of the bare skin. In one or two or

even all three of the caps show a disposition not to heat up, the caps have not been fitted properly and the clutch should be thrown out.

10—A cool cap is a sure indication that there has not been enough rock to the cap, and this may have been brought about by some nick or obstruction on the babbitt which stuck up above the rest of the surface and gave the cap a raise from the shaft. Then when the bolts were set down, the protruding lump was pressed into the rest of the babbitt and the bearing cap has a nice loose fit which makes it absolutely impossible to burn it in. The cool caps must be caught immediately, as otherwise the whole

burning-in operation will have to be done over again.



*Fig. 43—This is a clamp for holding the crankshaft while polishing the cranks preparatory to fitting the bearings. It obviates the necessity of using an ordinary vise and makes the shaft rigid and convenient to work on*

11—Remove the cool caps and take them down on the emery cloth or abra-

sive stone exactly the same way as they should have been fitted up in the first

12—Continue the operation the same as when starting the first time.

13—The total time the machine takes to burn in the bearings is in the neighborhood of 2 minutes, but this may vary with the exact tightness of the caps in the first place, the grade and softness of the bab-bitt and the speed of the machine.

14—It is an excellent plan to throw out the clutch at the end of 1 minute and try the handwheel. If it cannot be turned with one hand, the bearings are not done. Try again at the end of 1½

minutes and frequently thereafter till a point is reached when the handwheel can just be turned with one hand. This

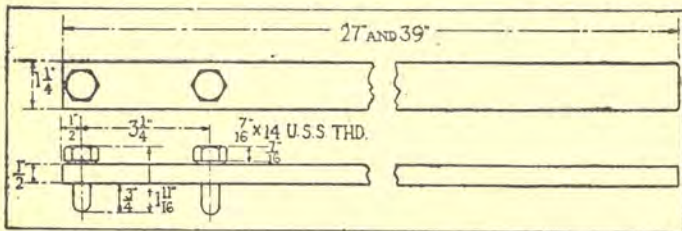
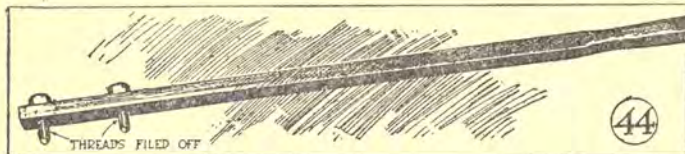
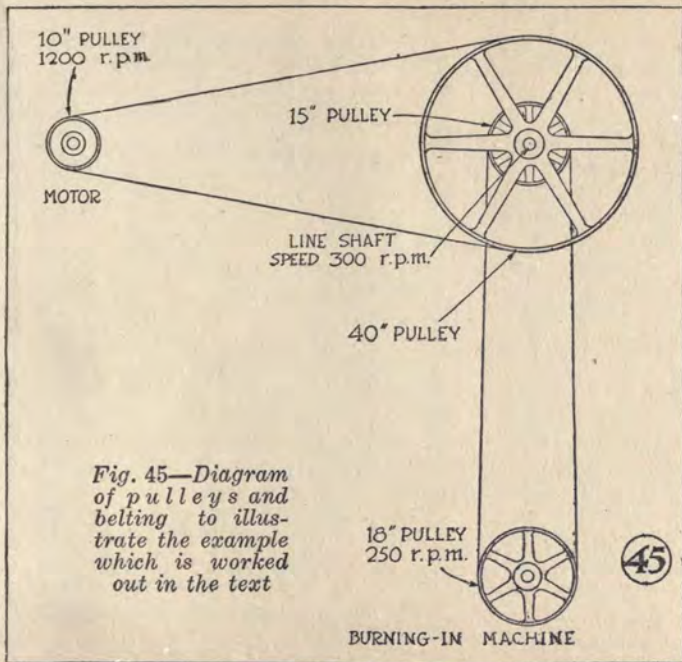


Fig. 44—Two views of the turning bar which is used in turning the crankshaft around when the flywheel is removed

place. The rock should be between .004 and .006 in. No allowance is to be made for heat in this case.



*Fig. 45—Diagram of pulleys and belting to illustrate the example which is worked out in the text*

is the proper freeness of the bearings at this point. After they are oiled and run in on the stand later, they will loosen up a little more.

### Connecting-Rod Bearings

15—Apply oil freely to the main bearings so that they will not burn in any more while the connecting-rod bearings burn in. This application of oil will also put a polish on them during the running.

16—Remove the block from the machine and insert the pistons complete with rings and rods. Be sure to get the pistons into the cylinders they have previously been fitted to as shown by the marks.

The clamp screws on the upper ends of the connecting rods all go toward the camshaft side of the engine and the bearing caps are then put in place.

17—The same method of taking down the caps or shifting liners to get .004 to .006 in. rock is gone through as was the case in fitting up the main bearings.

18—The caps are taken down the necessary amount on emery cloth or an abrasive block, and it is even more important in the case of the connecting-rod caps to use this method than in the case of the main bearing caps, because the connecting-rod caps are smaller and it is much easier to file them with a twist, giving an unsatisfactory and short lived bearing.

19—Set the nuts up tight as possible.

20—Put the block in the machine, engage the driving head with the flange of the crankshaft and set up the clamps.

21—Try the handwheel as a check. It should not be possible to turn it.

22—Oil the pistons and cylinders and give the main bearings another dose of oil, but do not allow any oil to get on

or near the connecting-rod bearings.

23—Throw in the clutch, carrying out the same precautions as in the case of starting to burn-in the main bearings.

#### Attend to Cool Rods Immediately

24—Time the operation as before and throw out the clutch after 30 seconds to see if all the rods are heating up as they should. Any cool rod should be attended to at once, taking down the cap until there is the right amount of rock.

25—Continue the operation of the machine for a minute and try the handwheel. If it will not turn with one hand, continue, trying the tightness at short intervals, till the handwheel can be turned with one hand.

26—When the bearings are done, apply oil and run for a few minutes longer to get a little polish on the bearings.

27—The block is now to be removed from the machine and is ready for assembly as soon as the other components of the power plant have been repaired or overhauled as the case may be.



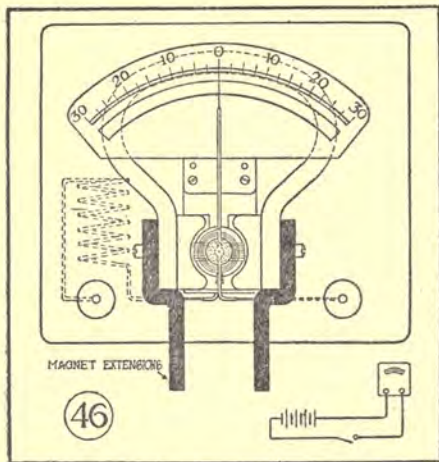
## CHAPTER XIII

### Testing and Overhauling the Magneto

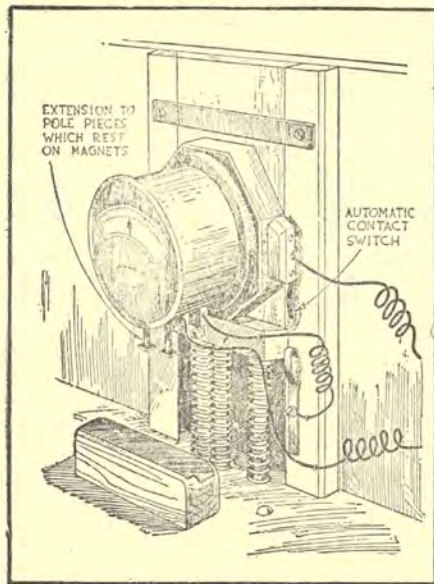
THE Ford magneto consists of but three main parts and they are so simple to understand and so readily tested that no engine should be assembled without making sure that each of the components is in good mechanical and electrical condition. The only requirements are that the magnets have a sufficient amount of magnetism or pulling power, that they are assembled correctly on the face of the flywheel, that the coils are neither open circuited nor short circuited and, finally, that the contact is in such shape that it will conduct the current generated by the magneto to the place where it is supposed to go.

A most handy and convenient arrangement for testing the strength of the individual magnets is shown in Figs. 46 and 47. A slide allows the flywheel with the magnets in place to be pushed under the measuring instrument and held evenly balanced in this position.

The measuring instrument is a direct current voltmeter with a range of 30-0-30 volts. Two extensions made of soft iron extend down from the poles of the magnet in the instrument, and they are spaced so that they touch the ends of the Ford magnets. The theory is that the voltage shown on the dial of the instrument will be proportional to the strength of the magnet being tested when a constant current such as that from a few dry cells is sent through the meter. By comparing the voltage registered when a magnet known to be good is placed under the instrument with the voltage shown on the one under test, the exact strength of the magnet can be determined. The correct strength may run anywhere from 5 to 12 volts with six dry cells connected up, but each instrument must be tested up with a good magnet and the calibration secured in this way. Any standard voltmeter can



*Fig. 46—Diagram of the arrangement used on a voltmeter to adapt it to measure the strength of the Ford magnets. The extensions to the magnet in the instrument are soft iron*



*Fig. 47a—The complete apparatus for testing the Ford magnets*

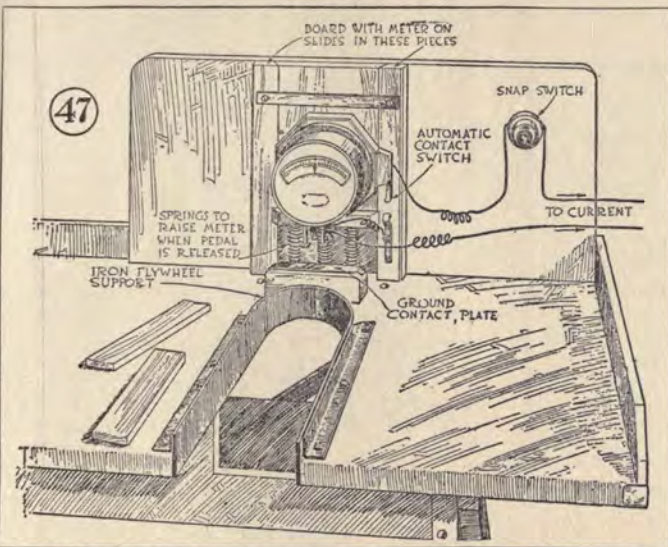


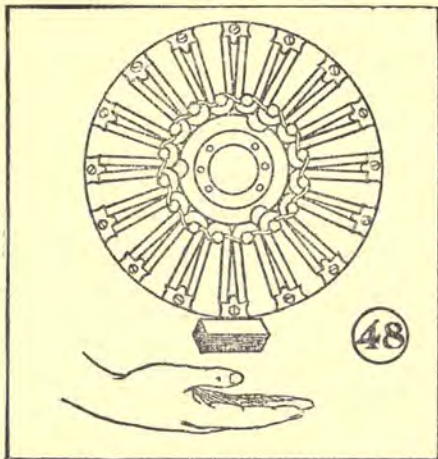
Fig. 47b—The instrument is mounted on a sliding board which is held up by a spring and depressed by a foot lever under the bench. The current is only connected when the test is being carried out. An automatic switch may be installed to cut it off at other times.

be altered by any instrument maker when the conditions are known.

In case the testing instrument described above is not available, the test can be carried out a little less accurately but reliably by hanging a block of cast iron or steel from the poles of each magnet in turn.

1—Each magnet should be capable of lifting 2 lb.

2—Cut out a piece of soft steel such as cold rolled to the dimensions of  $1\frac{3}{8} \times 1\frac{3}{8} \times 3\frac{9}{16}$ . This will weigh just a shade under 2 lb. If it is not possible or convenient to cut it to these dimensions, use any



*Fig. 48—A block of steel weighing about 2 lb. should hang from the magnets if they are of the correct strength. If they are too weak, the block will drop off.*

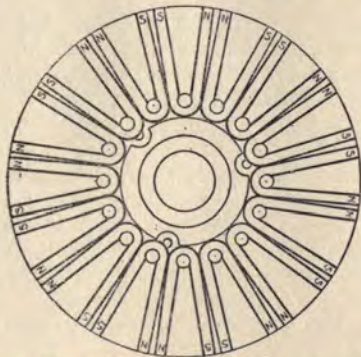
other sizes that will bring the piece to a size so that it contains  $6\frac{3}{4}$  cu. in.

3—Hold the flywheel vertically or in the position which it assumes when in the engine and hold the block of steel to each pair of magnet poles in succession. *The test is to be made on each pair of like poles, that is, a pole of one magnet and a pole of the next magnet, not the two poles of the same magnet.*

4—If the magnet will sustain the weight, it has sufficient strength, but if the weight drops off, then the magnet is too weak.

5—Regardless of which method of testing has been used, if one or more of the magnets is found under strength, an entire new set should be installed. The new magnets come from the branch or factory mounted on a board just in the position that they should be on the flywheel. However, a method of checking up the polarity of the magnet poles will be explained further on in this chapter.

6—When assembling or disassembling the magnets, if the flywheel is separated from the transmission, two pieces of



*Fig. 49—Diagram of the correct assembly of the magnets on the flywheel.*

wood about 1 in. thick should be laid on the bench so that the flywheel will have a good solid base to sit on while the cap screws are taken out or put in

as the case may be. If the flywheel is still on the transmission, then the whole unit can be set in a box made so that the sides support the rim of the flywheel.

7—Cut the locking wire that runs through the heads of the steel cap screws nearest the center of the flywheel.

8—Remove the bronze screws that hold the pole pieces of the magnets down. These are or should be riveted after they are screwed in, so that the cheapest and most effective method of taking them out is to cut the riveted parts off with a chisel and replace them with new ones.

9—Remove the steel cap screws from which the locking wire has been previously removed.

10—The magnets can now be lifted right off the flywheel.

11—Clean off the flywheel, the screw holes and the magnet pole pieces.

### Remagnetizing Magnets

A question that has caused a lot of discussion is whether it is practical to remagnetize Ford magnets rather than

replacing them with new ones. There are several answers to this.

1—It is perfectly possible to recharge the magnets by any one of a number of different methods, but the expense of operating the charging mechanism, the skill required to get each magnet the same strength and the possibility that the magnet may go back again on account of softness or other causes, makes it inadvisable to attempt the operation unless it can be done on such a scale that one man can give pretty much all of his time and experience to it so that the results can be guaranteed.

2—It is even possible to remagnetize the magnets by sending a current of electricity through the coils when the magneto is assembled in the engine, but the magnets have to be very accurately in front of the proper spools, the right amount of current must be put through the coils and kept connected for just the proper length of time. The possibility of reversing the poles is so great that there is only one chance in five of the operation turning out a success.

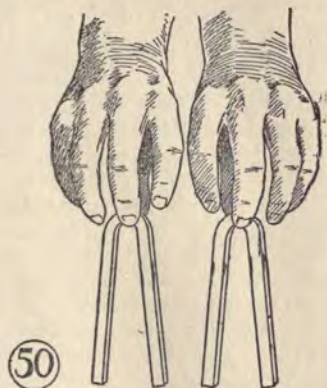
*Neither of the methods mentioned in operations Nos. 1 or 2 is recommended or countenanced by the Ford Motor Co., or any of its branches, but the question is asked so often that we cannot pass over the subject of the magneto without making brief mention of the two methods and their disadvantages.*

3—Dropping a magnet on the floor is very likely to cause it to lose its magnetism. Hammering or vibration will have the same effect, therefore the magnets should be handled with the utmost care and should be tested with the meter after having been assembled to the fly-wheel in order to learn whether anything has happened to them in the meantime.

### Magnet Polarity

Every permanent magnet has two poles, a north and a south, and the magnets which form a part of the Ford magneto are no exception to this rule. It is immaterial which is which, but the magnets must be assembled so that the north pole of one magnet is held

under the same pole piece as the similar pole of the next magnet. The next two



*Fig. 50—This is the method used in determining the polarity of the magnets.*

poles will be south, then two north, and so on.

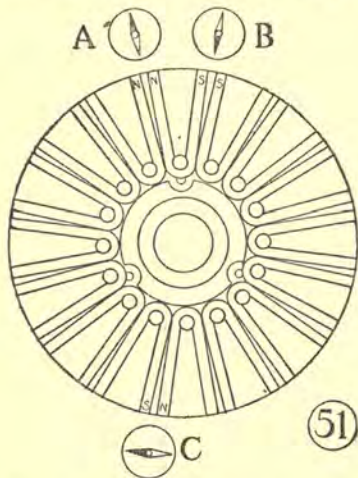
1—To tell which pole is which, hold

two magnets close together. If two of the poles attract each other, then these are unlike poles, because unlike poles attract. In other words, one is a north and the other is a south. To get the like poles together, simply reverse one of the magnets. In this position the poles will not attract each other but will have a slight repellent action which will not be quite so marked as the attractive action of the unlike poles. (See Fig. 50.)

2—Another method that is often used is to bring a small pocket compass near the poles. After the magnets are assembled on the flywheel, if the compass is moved slowly around the outside of the flywheel, the needle should take a violent jump and reverse its position every time it passes from one set of poles to the next set. If at any pair of poles the needle just wiggles and does not seem to know which way to turn, this indicates that this pair of magnets is wrongly placed. (See Fig. 51.)

3—One magnet improperly placed will cause a considerable reduction in the

voltage of the entire magneto and will also make it jumpy so that missing may result. It might be possible to run the



*Fig. 51—Using a compass to determine the correct assembly of the magnets.*

car after a fashion with one magnet in wrong, but all the other equipment would most certainly have to be in the very pink of condition to do so. No job should ever be allowed to pass through with a single magnet in wrong.

4—After ascertaining the polarity and arranging the magnets the way they should go, put them in place on the fly-wheel.

5—Catch the center retaining bolts in the holes, but do not tighten them up. These are the steel bolts.

6—Slip the outside spools under the ends of the magnet poles.

7—Put the pole pieces in place.

8—Catch the brass screws, which should be new ones, in their holes.

9—Set the screws down tight with a brace screwdriver.

10—Pinch the ends of the magnets ir with a pair of pliers until the sides of the magnets rest against the lug on the pole pieces.

11—Tighten the brass screws again.

12—Tighten the central bolts.

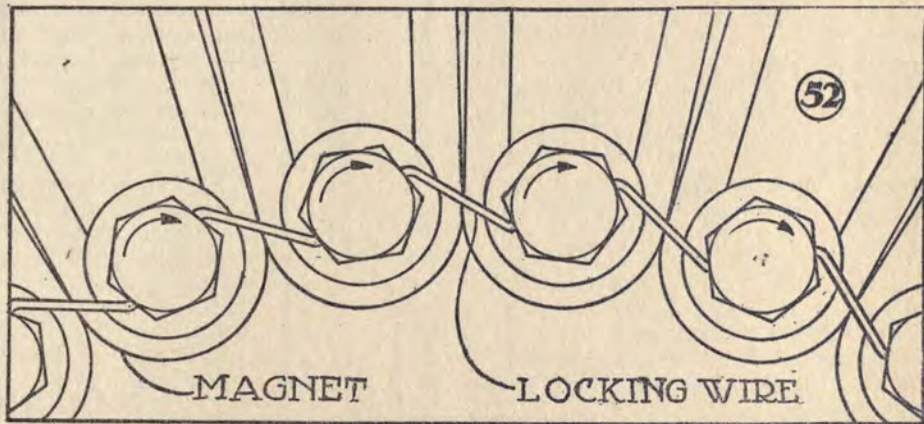


13—Put a new locking wire through the steel bolts, getting it as tight as possible and then twisting the ends together.

14—In inserting this wire, put it

through the holes in the manner shown in Fig. 52, as this creates a tendency to tighten the bolts rather than loosen them.

15—Knock the four corners of the



*Fig. 52—This is the way the wire should be run through the heads of the bolts. If run through the other way, there is a tendency to loosen the bolts when the wire is pulled tight*

pole pieces down over the magnets so that there will be no chance of their

catching in the coils when the parts are assembled.

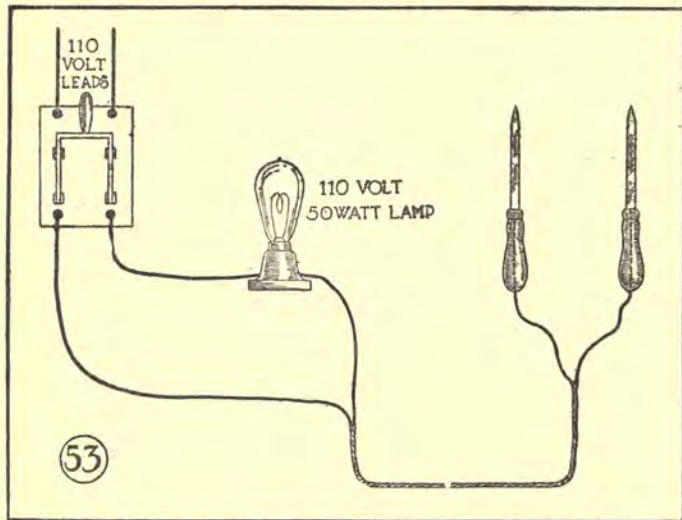


Fig. 53—Diagram of the connections of test points and lamp for testing with a 110-volt circuit

### Replacement Coils and Magnets

In replacing sets of magnets it should be noted that 1909 and 1910 cars used magnets 9/16-in. thick (order number 3275), together with coil assembly No. 3250B, both of which are now obsolete. Replacements should be made with magnet assembly No. 3276B, the magnets of which are 3/4-in. thick and the thinner coil No. 3250D will fit in the assembly with this.

From 1911 to 1914, the magnet assembly No. 3276 was used, and these were 5/8-in. thick. Coil assembly No. 3250C

was used with this assembly, and these should be replaced with magnet assembly No. 3267B and coil assembly No. 3250D, the same as in the other case.

### Testing the Coils

Each one of the coils on the coil assembly consists of a number of turns of copper ribbon running around the soft iron core. Adjacent coils are wound in the opposite direction. This, with the alternating arrangement of the magnet poles which pass in front of the cores, produces the alternating current in the magneto.

In order that the magneto may deliver the current which is generated to the terminal on top of the transmission cover, it is necessary that the circuit be continuous from the point where the first coil is grounded to the frame to the contact on the last spool which connects with the magneto terminal. Any break in this circuit will result in a dead magneto.

Of equal importance is the perfect insulation of the coils from start to finish.

If there is a short circuit from the coils to the frame the current generated by the magneto will either be so weak as to seriously interfere with correct ignition, or there may be no current at all, depending on just which coil is shorted.

Tests for short circuits and open circuits on the coils are carried out by means of an electric lamp connected to some form of current. It really does not make any difference whether a battery is used or whether the current is taken from the electric light mains, although the latter is more convenient in most cases. Both ways are described.

### Using Electric Light Current

1—Connect up a set of test points with a switch and electric light, as shown in Fig. 53. For 110-volt current use a 50-watt lamp. Fuses of 6-ampere capacity should be used to protect the wiring. The cord is ordinary braided silk covered flexible conductor and the test points can be bought ready made or can be made up in the shop. They are simply wooden

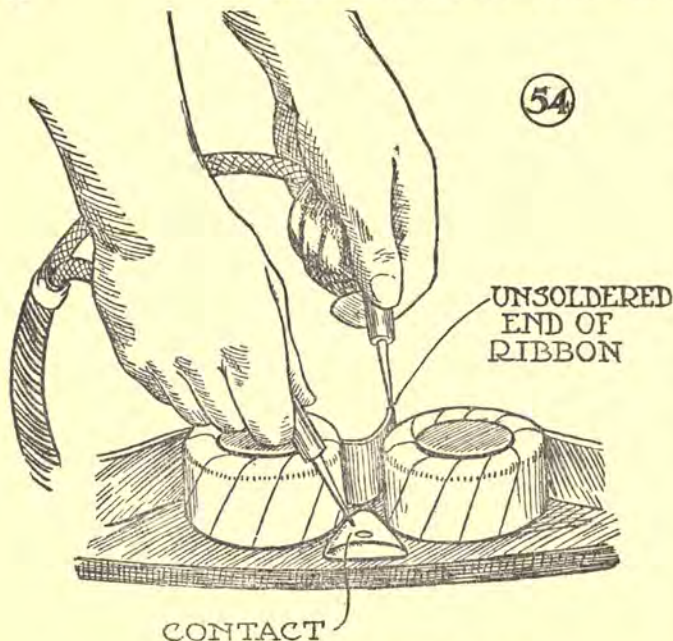


Fig. 54—Testing for open circuit

handles with steel or brass points, the ends of the flexible cord being soldered to the points so as to make a good connection.

2—Before making any test at any time close the switch and touch the two points together to see if the light is in working order. When the points are touched together, the light should light.

#### To Test for Open Circuits

3—To test for open circuits, unsolder the end of the coil ribbon from the sheet steel frame. This can generally be done by prying it off carefully with a screwdriver, taking

care not to break the ribbon off, but simply to pry it loose from the solder. If there happens to be too much solder, melt the solder with a hot soldering iron or a fine jet from a torch. (See Fig. 55.)

4—Hold one of the test points to the unsoldered end of the ribbon and the other to the bare metal against which the magneto contact presses. If the circuit is continuous throughout the coils, the light will light. If it does not light, there is a break somewhere. Be sure in making this or any of the other tests that the test points make a good metallic contact. Scrape off any



Fig. 55—Testing for short circuit

shellac, oil, grease or other material till a bright clean surface is obtained and touch the test point to this spot.

5—To test for a short circuit, the grounded ribbon must be unsoldered just

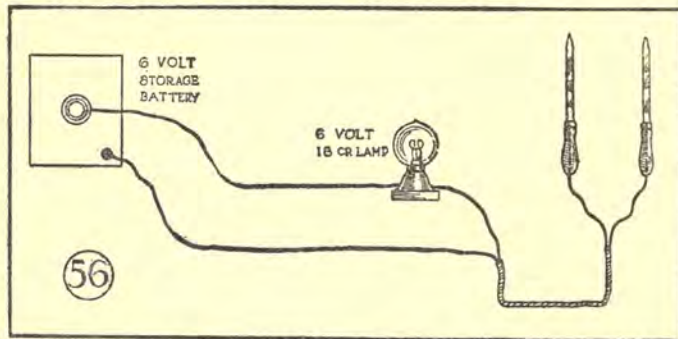


Fig. 56—Diagram of the connections for test points and lamp using a 6-volt storage battery

as in the other test, but in this case, one of the points is touched to either the unsoldered end of the ribbon, or the

contact end. The other point is touched to any point on the sheet steel frame or to one of the iron cores. Use the same precaution to get a good metallic contact, scraping off the shellac or other material that might prevent such good contact.

6—If the coils pass these two tests, they are in good serviceable condition and can be assembled into the engine at any time after the ground connection is resoldered to the frame.

7—If the coils do not pass the test, a new set of coils should be installed. It is possible to repair defective coils sometimes, but it is

cheaper and makes a better job to replace the whole coil unit.

8—If the coils are replaced be sure

that the correct magnet set is installed on the flywheel. The groups are explained under the heading of "Replacement Coils and Magnets," page 90.

9—If the coils and magnets have been tested and assembled according to these instructions, there is no possibility of the magneto not working unless some damage is done to it between the tests and the assembly of the engine. Later operations will tell how to test the magneto after the engine assembly is complete. The gap between the coil cores and the magnets is  $1/32$  in.

#### Using a Battery and Light

10—If the tests are to be carried out with a battery current instead of the electric light current, the connections are hooked up, as shown in Fig. 56, and the test then made in exactly the same manner. Of course it would be

necessary to use a low voltage lamp instead of the 110-volt lamp, and a handy size to use would be 6-volt 18 c.p. if a 6-volt battery is used. Do not use a battery when it becomes so weak that the current is unreliable. A slight resistance at the test points may throw the test all out.

11—Tests can even be made with the regular bell-ringing magneto, which is used in electrical line testing, but it is not so handy or convenient as the electric light method and it takes one more hand to turn the magneto crank.

A storage battery makes the best source of current for this purpose, and when it gets run down it should be recharged or replaced with another one in good condition.

Dry cells can also be used, but not less than six cells should be hooked up to get sufficient voltage to overcome slight resistances at the points.

## CHAPTER XIV

### Overhauling the Transmission

**T**HE usual trouble with a transmission that is brought in for overhauling is worn bushings which allow the drums to wobble. To rebush the drums requires the complete dismantling of the unit.

1—The front universal ball cap with the bearing included will no doubt have been removed before this, but it should be fitted up to the rear end of the driving plate shaft to see if there is any looseness. If there is, a new ball cap with new bearing should be installed when the transmission is assembled. The bands will slip right off the drums to the rear.

2—In most cases it is not necessary to entirely disassemble the parts from the transmission driving plate assembly and the spring, pin, etc., can be left as they are.

3—Remove the locking wire from the screws that hold the transmission driving plate to the brake drum and remove the screws.

4—The unit is then tipped over dropping out the clutch push ring and the clutch disks.

5—Remove the lock stud that keys the inside clutch drum.

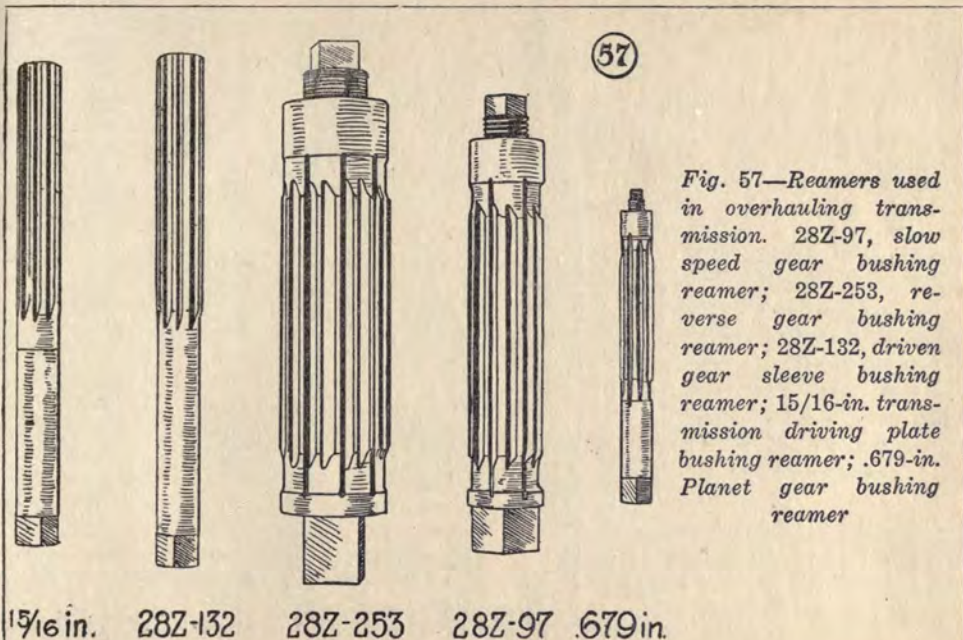
6—Remove the drum and key with a puller.

7—The drums together with the triple gears can now be slipped over the shaft, starting the shaft if necessary with a babbitt hammer.

8—Pull the driven gear with its key, thus releasing the two drums from the brake drum.

9—If necessary to disassemble the spring, the unit may be put in a vise, compressing the cup, then driving out the pin. This will release the clutch

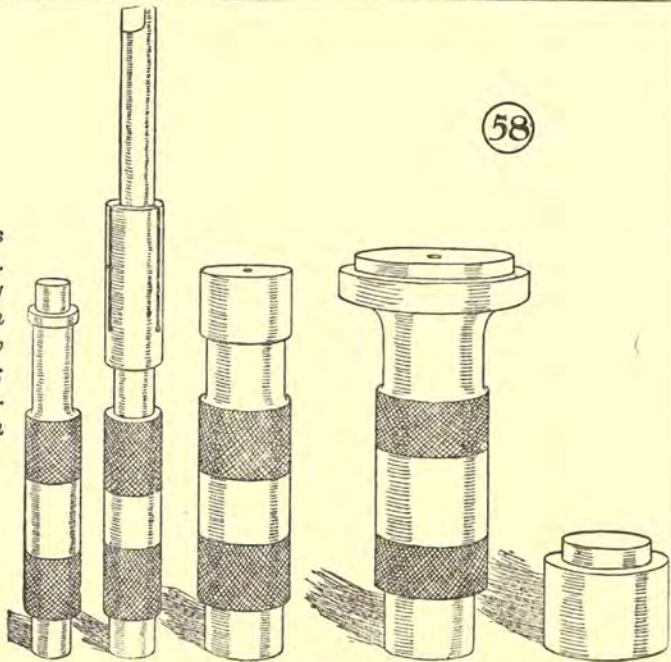




*Fig. 57—Reamers used in overhauling transmission. 28Z-97, slow speed gear bushing reamer; 28Z-253, reverse gear bushing reamer; 28Z-132, driven gear sleeve bushing reamer; 15/16-in. transmission driving plate bushing reamer; .679-in. Planet gear bushing reamer*

58

*Fig. 58 — Arbor press tools for transmission.  
A, triple gear bushing reamer; B, brake drum bushing driver; C, slow speed bushing driver; D, reverse drum bushing driver; E, driven gear puller block*



shift, the spring, the spring support and the thrust ring.

10—Clean the clutch disks in gasoline or kerosene and if they are cut or scored they should be discarded and new ones should be inserted when the clutch is reassembled. Slight scores may be smoothed out, but in case of doubt it is better to replace them.

### Replacing the Bushings

An arbor press is almost indispensable in removing and replacing the bushings in the transmission and it is used for the same purpose in rebushing various parts of the front and rear axle.

1—Place one of the drums on the plate of the arbor press with the round block shown in Fig. 59 underneath. This block is necessary to take the push of the press, otherwise this push would be taken by the rim of the drum and this would most certainly break or twist the drum.

2—Use the proper driver to fit the drum being operated on. The drivers used for transmission work are shown in

Fig. 58. Each is the correct size and has the right kind of a shoulder on so that the new bushings will not be damaged when pushing them in.

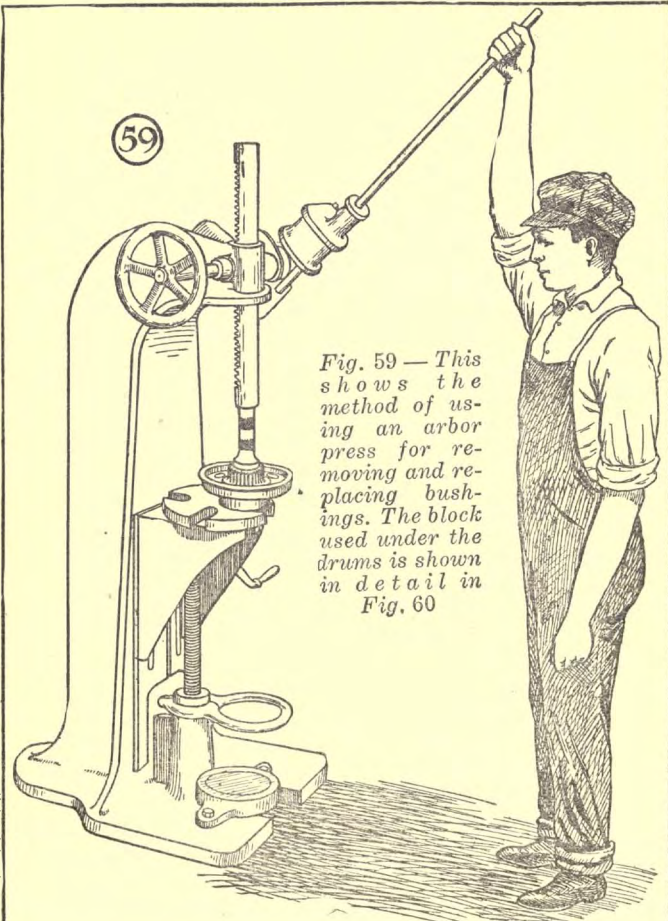
3—All three of the drums are to be rebushed in this way. See that the new bushings are a tight fit and if they are not, see whether the new bushing is at fault or whether the drum in some way has had the hole enlarged. If these bushings do not fit tight, it will be impossible to secure a satisfactory job.

4—The triple gears are to be rebushed in the same way, but before rebushing they must be tested to see if the rivets are tight and that there is absolutely no motion between the gears.

5—If it is necessary to re-rivet the gears, cut the heads of the old rivets out with a cold chisel.

6—Line the three gears comprising the unit up so that the teeth of all three gears are in line at one place. This will occur at only three points of the circumference of each set of gears.

7—Insert new rivets in the holes.



*Fig. 59 — This shows the method of using an arbor press for removing and replacing bushings. The block used under the drums is shown in detail in Fig. 60*

8—Head the rivets up on a jig like the one shown in Fig. 63. This will hold the heads of the rivets without disturbing the position of the gears.

### Reaming the Bushings

After the bushings have been pressed into the drums and gears, they must be reamed out to the correct size. Fig. 57 shows all the reamers necessary in reaming the bushings of the transmission.

1—Clamp the drums one at a time in a clamping device similar to the one shown in Fig. 61 or Fig. 62. This will hold the drum rigid and will not deface or scratch the surface of the drum and at the same time will allow the operator to use both hands on the reamer.

2—Run the reamer through each bushing all the way. In using a reamer, never turn it backward either to free it of cuttings or to take it out. Reamers that are always turned in a forward direction will not get dull as quickly as those that are turned backward from time to time.

3—The reamer must be held steady; chattering and an uneven hole will be the result otherwise.

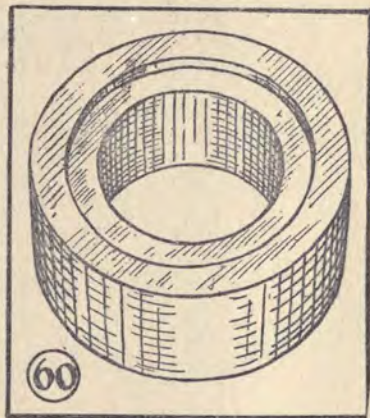


Fig. 60—Transmission drum support which is placed under the drum

### Assembly of the Transmission

1—The group consisting of the three drums, the driven gear and the triple

gears is the first thing to be assembled.

2—Put the brake drum (which is the one with the longest shaft) on the bench

4—Put the reverse drum over the slow speed drum so that the reverse gear surrounds the slow speed gear.

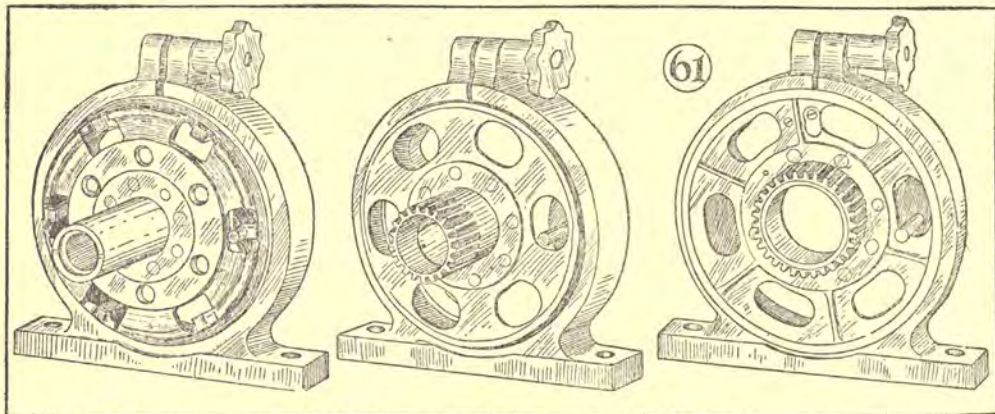


Fig. 61—A transmission drum clamping device for holding the drums while reaming the bushings. The tool is bolted to the bench and the faces of drums are not injured

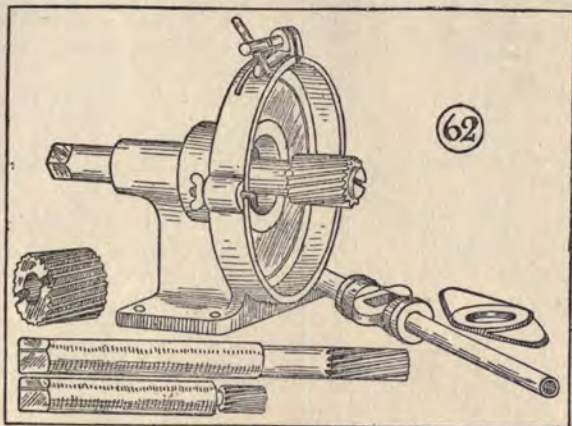
with the shaft or hub uppermost.

3—Put the slow speed drum on over this, the gear, of course, being at the top.

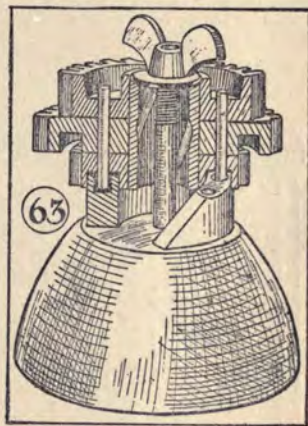
5—Slip the driven gear in place with the teeth downward so that they will come next to the slow speed gear, the two

Woodruff keys having been previously put in the two slots in the brake drum

far enough so there is no lost motion, yet so that the drums do not bind.



*Fig. 62—Another type of drum clamping device. This one has an extension to steady the reamer*

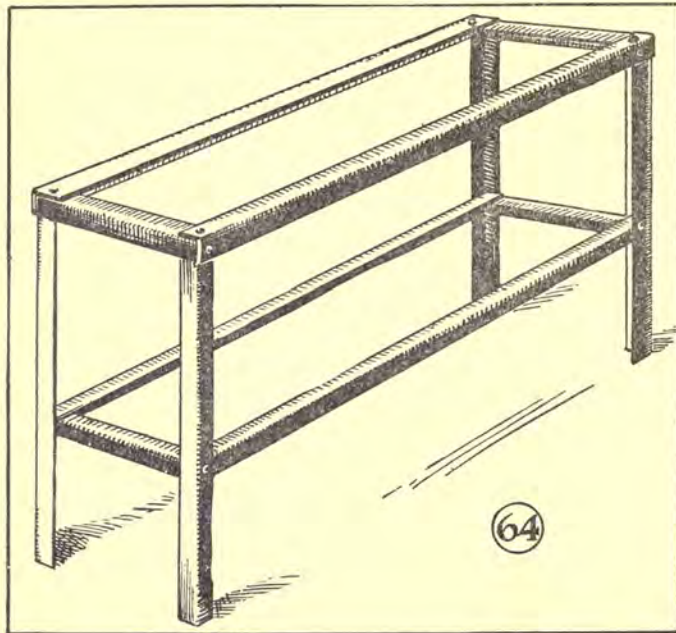


*Fig. 63—A jig for riveting the triple gears together*

hub. An arbor press can be used to force the gear into place.

6—The gear should be driven on just

7—Mesh the three triple gears with the driven gear so that the punch marks correspond, the smallest of the three gears



comprising the triple gear assembly being at the bottom.

8—Space the three triple gears around the driven gear so that there is an equal distance between them.

9—Tie string around the outsides of the triple gears to hold them in this position.

10—Examine the triple gear studs on the flywheel and replace if they are worn.

11—Place the flywheel face down on the bench.

---

*Fig. 64—A stand for holding flywheels, coil assemblies, etc. It is made of angle iron and will accommodate assemblies on top and on the shelf*



12—Turn over the assembly of drums and triple gears and slide them on the transmission shaft.

13—The studs should enter the holes through the triple gear bushings; if they do not do so readily, shift till they do.

14—Fit the clutch drum key in the transmission shaft.

15—Press the clutch disk carrier in place on the shaft.

16—Lock in position with set screw.

17—Put the distance plate on over the clutch drum.

18—Replace the clutch disks, starting with a small one, then alternating large and small. A large disk must come last as a small one would be liable to slip over the edge of the drum when the clutch spring is released.

19—Put the clutch push ring on over the clutch drum and on top of the disks. The three pins should project upwards.

20—Bolt the driving plate in position, the three pins of the push ring coming through to make contact with the adjusting screws on the clutch fingers.

21—If the transmission is properly assembled up to this point, the flywheel will revolve freely while any one of the drums is held stationary.

22—Slip the clutch shift over the hub so that the small end rests on the ends of the clutch fingers.

23—Put the clutch spring in place, the clutch supports being inside so that the flange will rest on the upper coil of the spring.

24—Place the clutch-spring thrust ring in place with the notched end down.

25—Compress the spring so that the pin can be put through the hole in the side of the spring support and then through the shaft. In order to compress the spring, the adjusting screws of the clutch fingers should be loosened all the way.



(65)

Fig. 65—  
Transmission  
turning bar

26—The only adjustment is that on the clutch and the three screws should be set up so that each one has the same number of turns. If they are screwed in until the clutch spring is compressed to a length of 2 1/16 in. the clutch should have sufficient hold to drive the car without any trouble.

The transmission can now be assembled to the engine at any time that the engine is ready.

#### Transmission Bands

If the shop is a small one, it will probably be found more profitable to install the new bands already lined as they come from the factory or branch, but where a large number of jobs are handled, it will be found profitable to save such bands as are still in good condition as far as the metal parts are concerned and reline them when work in some department of the shop slacks up enough to spare one or two men to do a bunch of the work at once.

1—Rip off the old lining and extract the old rivets.

2—Straighten up the metal parts if they are bent or if the strap is kinked or twisted.

3—The size of the brake lining is 23½ x 1½ x 5/32 in. Do not use brake lining with wire insertion or metal of any kind as this will wear off and eventually short circuit the magneto.

4—An old transmission brake drum can be held in the vise by its shaft or can be mounted permanently on the bench with some pipe fittings after the manner shown in Fig. 66.

5—The band with the lining in place is placed around the drum and the rivets driven through the holes. Brass rivets only must be used and these are 9/64 in. diameter and either ½ or 9/16 in. long. When the rivets are driven through the band and the lining they will clinch themselves on the drum and an extra blow will compress the lining enough so that the ends of the rivets will countersink themselves a short distance into the lining.

### Assembling the Bands

6—The bands should now be given a final straightening out around the drum so that they will be as round as possible and fit the drum without dragging at any one point.

The bands can be assembled to the drums with much more facility if this is done before the crankcase is assembled to the engine.

1—Slip the bands on the drums with the lugs upward.

2—If the bands are given a slight twist inward before they are put on, there will be enough friction to hold them in this position until the crankcase and transmission cover assembly is put on.

3—In assembling the bands with the crankcase on, the bands must be turned with the lugs downward and slipped over ahead of the forward drum.

4—Assembly will be facilitated if the flywheel is turned so that one set of triple gears is about 10 deg. to the right of top center.

5—The band is then pushed one way or the other until it has gone over all the gears.

6—The first band to be put on is slipped to the rear drum, the second to the middle, and the third to the front.

7—The bands must be turned with the lugs uppermost while they are over the triple gears as this is the only place where there is enough clearance to allow the lugs to be turned around.

8—A U-shaped piece made out of 5/16 or 3/8-in. drill rod is put over the lugs when they are all in an upright position. This will hold the lugs in so that the pedal shafts will rest in the notches when the transmission cover is put on. It will be impossible in this case to contract the bands so that they will stick to the drums and stand up themselves as the slipping on over the triple gears will have bent them outward. See Fig. 67. In lieu of the U-shaped rod, a piece of heavy cord may be used, but this is not as quick or as handy.

9—When putting the transmission cover on, the clutch release ring must be placed in the rear groove of the clutch shaft.

10—The U-shaped piece can now be pulled out and the lugs of the bands will be just where they belong.

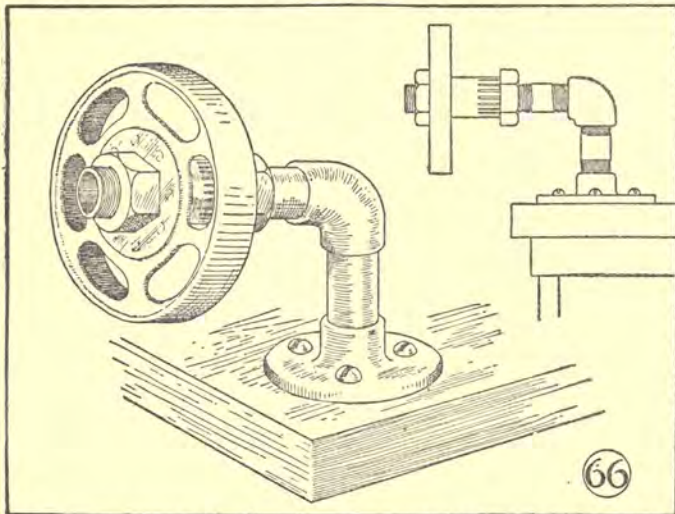
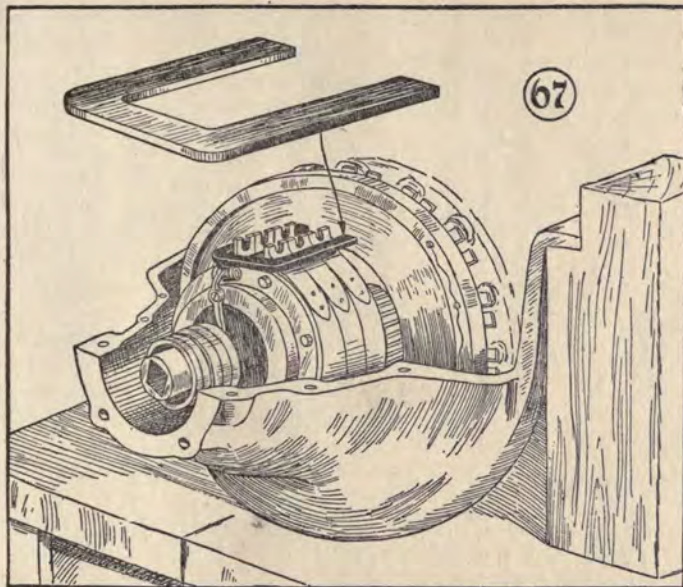


Fig. 66—A jig for clinching the rivets in the transmission brake linings

The jig shown in Fig. 66 is, as stated in operation No. 4, an old transmission brake which is a standard drum. A floor flange, pipe fitting, is securely bolted to the bench in such a position that the drum, when attached, will overhang the end of the bench by several inches. The upright is a close nipple which screws into both the floor flange and the elbow which is at the upper end.

The horizontal pipe is of a length to allow the drum to hang over the bench. It has a



*Fig. 67—The lugs of the bands are held together with a U-shaped rod so that the pedal shafts will rest in the notches*

standard pipe thread cut on the end that screws into the elbow and the other end is threaded long enough so that the threads will extend clear through the drum with enough over to allow a pipe locknut on both sides of the drum. This piece of pipe has to be specially threaded for this purpose and this can be obtained at any plumbing shop or it can be made up if the repair-shop has a set of pipe dies. In cutting a thread of this length it will be found easier to set the dies above standard and taking the thread in two or three cuts to standard.

## CHAPTER XV

### Reseating and Grinding Valves and Other Minor Engine Repairs

**W**HEN the valve seats are worn to a point where the seat is too wide, a remedy exists in the way of boring the port out larger, reamning the seat, and if there is wear in the guide; reaming the guide for oversize valve stems.

1—A tool for doing all three of these operations is shown in Fig. 68.

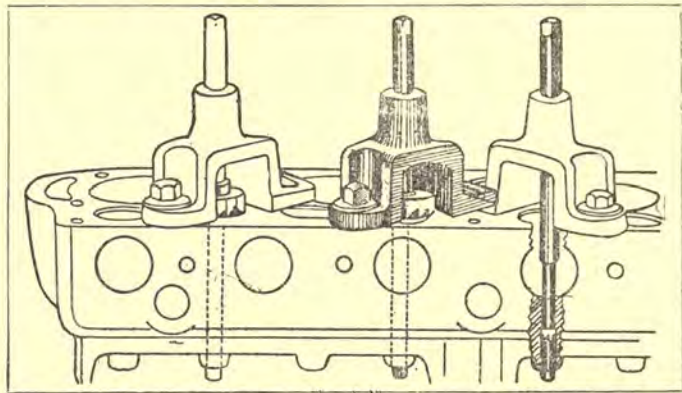
2—Place the enlarging reamer with the stem in the valve guide.

3—Put the clamp on over the reamer and set the bolts down tight.

4—Turn the reamer with a wrench until it goes all the way down

and enlarges the port the entire distance.

5—Replace the enlarging reamer with the seating reamer.



*Fig. 68—A tool for renewing the valve ports, the left showing the port enlarging tool, the center the reseating tool and the right the guide reamer*

6—Turn the seating reamer until a narrow even seat is formed.

7—Even light pressure is required on this reamer to prevent chattering and making an uneven seat.

8—Replace the reseating reamer with the guide reamer and run this all the way through, enlarging the guide to take the oversize valve stems.

9—The jig or clamp remains bolted to the cylinder head during all these operations, thus insuring the truth of the three operations. Two bolts are furnished which fit into the cylinder head bolt holes, and the jig is swung from one port to another by loosening only one bolt.

10—A straight reseating reamer for recutting the seat only is shown in Fig. 69. No clamp is necessary with this and the stem is simply inserted in the valve stem guide and the reamer turned until a good clean seat is obtained.

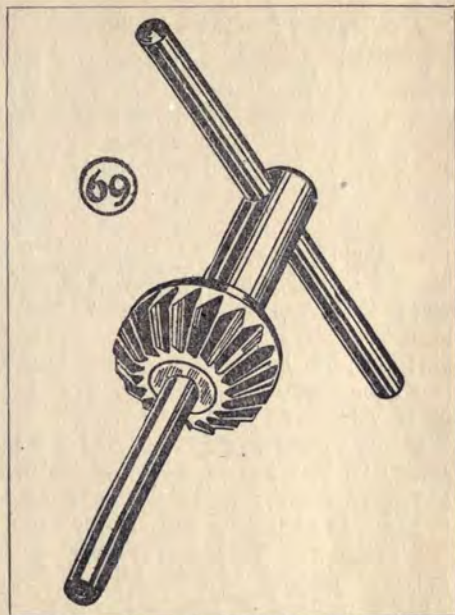


Fig. 69—A plain valve reseater

### Replacing Camshaft Bushings

1—When the camshaft bushings are worn, they should be replaced. They are removed from the casting, two of them being split and the other one being a one-piece bronze bushing. Clips hold the halves of the split bushings together.

2—A line reamer for the camshaft bearing is shown in Fig. 70. It is provided with two guide surfaces which bear in the casting so that the reamer part of the tool will ream the hole in the small bushing exactly in line with the other holes.

3—Before the camshaft is replaced it should be tested with the same testing and straightening press that was used in the case of testing and straightening the camshaft. This was shown in a previous chapter in Fig. 19 and 19A. Another method of testing is shown in Fig. 71.

4—If the crankshaft bearings have

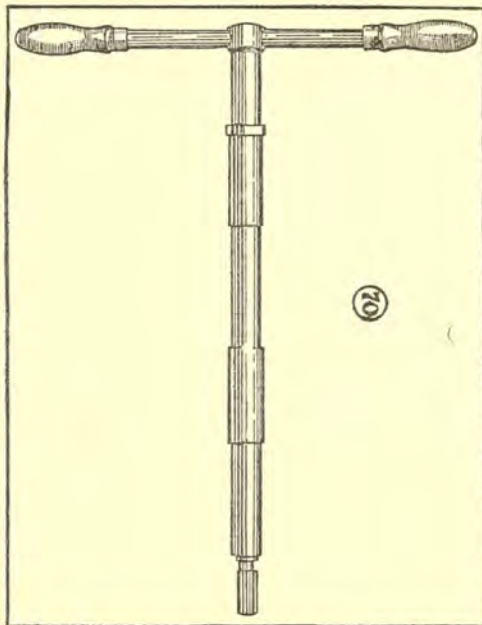
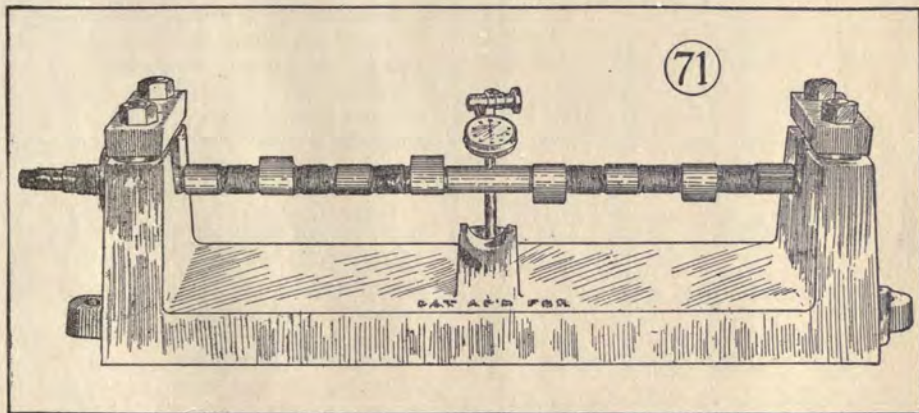


Fig. 70—Line reamer for camshaft bearing



been properly babbitted and burned in, the gears of the camshaft should mesh smoothly and nicely with the crankshaft

marks on the two gears should be put together and no further worry need be had over the timing.



*Fig. 71—A method of testing the straightness of the camshaft*

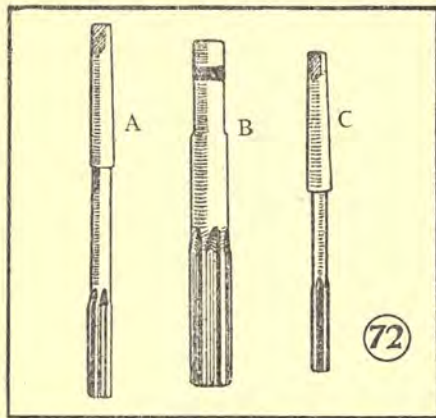
gear without grind and without any appreciable backlash.

5—In timing the gears, the punch

6—In case the punch marks have been removed by the use of a new gear or from other causes, the timing should

be made such that the valves and pistons have the following relation:

Exhaust valve opens when piston



*Fig. 72—A is the 29/64-in. reamer to ream the push rod holes 1/64 in. oversize; B is the camshaft bearing bushing reamer, and C is the 21/64-in. reamer for reaming the valve stem guides 1/16 in. oversize*

comes within 5/16 in. of bottom stroke, the distance from the top of the cylinder casting to the top of the cylinder head being 3 3/8 in. Exhaust valve closes on top dead center, the piston being 5/16 in. above the cylinder casting.

Intake valve opens 1/16 in. after top dead center.

Intake valve closes 9/16 in. after bottom dead center, the distance from the top of the cylinder casting to the top of the piston being 3 1/8 in.

7—In checking this valve timing, the clearance between the valve stem and the cam follower is supposed to be between 1/32 and 1/64 in.

The starting crank bushing should be replaced if it is worn so that there is considerable lost motion between the starting crank and the bushing. The bushing is simply pressed out in a press and a new one inserted.

### Brazing Crankcase Arms

1—Many large shops make a practice of riveting and rebrazing the crank-

case arms on all overhaul jobs which are turned out whether the operation is called for or not on the card. The advantage is that the job cannot be brought back by the owner to correct this fault later. It is a simple enough job when the crankcase is disassembled from the engine, but to do the job over requires taking the engine out of the car and taking it partly down, which is somewhat of an expense.

2—Either cut the old arms off with a chisel or melt the spelter with the torch.

3—Clean up the surface around the

arm so that it is bright and free from grease and oil.

4—Rerivet new arms in place, heading the rivets up with a ball peen hammer. A piece of shafting with a countersunk place in the top makes an excellent anvil.

5—Heat the vicinity of the arms up with the torch, applying borax and spelter when the proper heat is reached.

6—After brazing the arms, the crankcase should be tested to see if the heat has had any effect in the alignment. If it has, the crankcase should be straightened before assembly, as it will be hard to get the bolts in place otherwise.

## CHAPTER XVI

### The Carbureter

**F**ORD cars are fitted with either Kingston model L or Holley model G carbureters. In either case there is but one mixture adjustment, that being the needle valve. There are no supplementary air valves or anything else requiring adjustment providing the other parts of the carbureter are in perfect order.

#### The Kingston

The usual method of adjusting the carbureter is:

- 1—Start the engine.
- 2—Advance the throttle.
- 3—Retard the spark.
- 4—Cut down the gasoline supply by screwing down the needle valve in a clockwise direction until the engine begins to misfire.
- 5—Gradually increase the supply by turning the needle valve in the opposite direction until the engine picks up and

reaches its highest speed and with no trace of black smoke at the exhaust.

6—Tighten up the binding screw or locknut sufficiently to hold the needle valve in this position.

7—Should dirt or sediment clog up the spray nozzle, open the needle valve half a turn and give the throttle valve two or three quick pulls to race the engine. This will generally create sufficient vacuum at the needle-valve orifice to pull the obstruction through and the needle valve can then be reset to its correct position.

8—The drain cock should be opened occasionally to free the chamber of dirt and water.

#### The Holley

To adjust the carbureter:

- 1—Loosen the needle valve locknut until the needle turns freely.

2—Screw the needle valve in a clockwise direction until the needle valve touches the seat. Do not turn too far or use pressure on the seat and the point of the needle will be damaged. (See Fig. 74.)

3—Turn the needle to the left one complete turn. This is approximately the correct mixture for most cars, but it may vary between seven-eighths of a turn and one and one-quarter turns.

4—Screw the locknut down till it prevents the needle from turn-

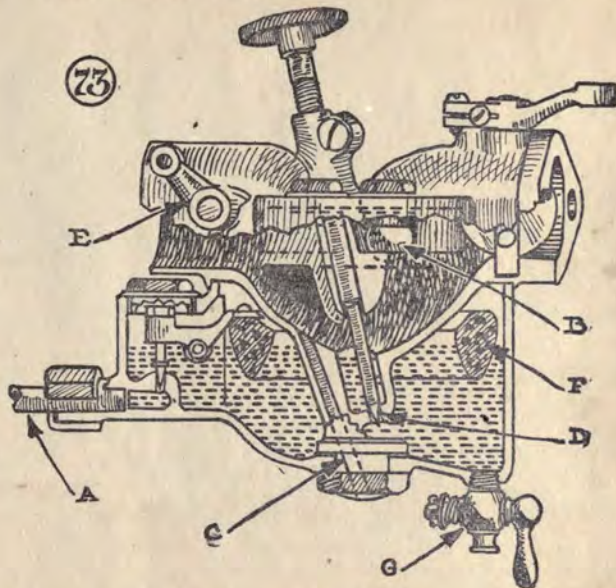


Fig. 73—Section of Kingston Model L carbureter. A is the fuel intake, B the air valve, C the low-speed tube, D the fuel nozzle, E the choke throttle, F the float and G the drain cock

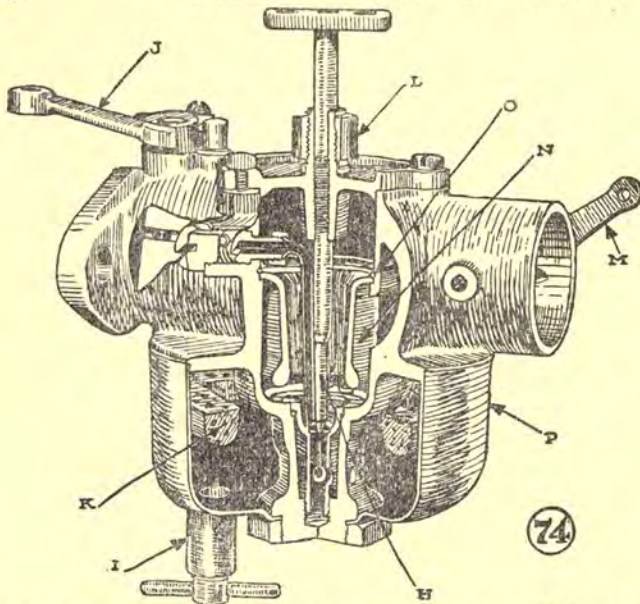


Fig. 74—Section of Holley Model G carbureter. H is needle valve, I drain cock, J throttle lever, K float, L needle valve locknut. M choke throttle lever. N choke tube. O locking ring

ing through vibration, yet is loose enough to be turned by hand.

5—Start the engine, choking if necessary, and let the engine warm up.

6—The adjustment can best be made by slipping the dash control rod out of the holes in the needle valve and turning the needle valve itself.

7—Turn the needle valve one way or the other till the engine does not backfire through leanness of the mixture, nor does black smoke come from the exhaust through richness.

### Setting the Float on the Holley

In any carbureter, the fuel level must be maintained at a certain height in the bowl so that it is slightly below the level of the fuel nozzle or needle valve. In the case of the Holley Model G (Fig. 74), there are certain set maximum and minimum levels outside of which the carbureter will not give satisfactory results. It is very easy to check these up with a gage.

1—Such a gage is made of flat steel stock  $\frac{5}{16}$  in. wide,  $\frac{1}{8}$  in. thick and 6 in. long. Fig. 75 shows the gage. A slot is filed in each end  $\frac{3}{16}$  in. wide and  $\frac{3}{16}$  in. deep. This leaves two points  $\frac{1}{16}$  in. thick at each end.

2—File one of these points at one end so that it is  $\frac{1}{16}$  in. lower than its mate.

3—File one of the points at the other end so that it is  $\frac{1}{8}$  in. lower than its mate.

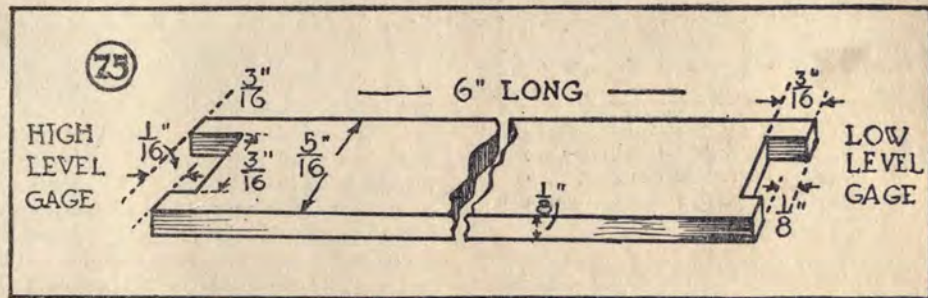
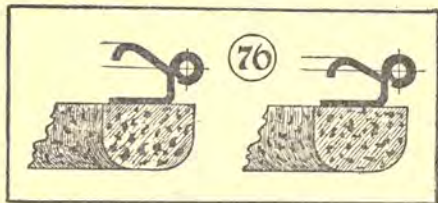


Fig. 75—Gage for testing the correctness of the float level in the Holley Model G carbureter

4—Inasmuch as the level of the gasoline in the bowl should be from  $1/16$  to  $1/8$  in. lower than the top of the nozzle, the points will show whether the level is too high or too low.

5—Place the gage so that the short point of the low-level end of the gage



*Fig. 76—Setting the float on the Holley. To lower the level, pry up the lever as shown at the left. To raise the level, push the lever down as shown at the right*

rests on the point of the cup at one side between the wrench lugs, holding the gage in a vertical position.

6—The gasoline should touch the long

point of the gage. If it does not touch it, the level is too low and the float should be adjusted accordingly. See later operations for adjustment of the float.

7—If the level of the gasoline comes above the longer point of the low-level end, turn the gage end for end and apply the same test, but this time the gasoline should not touch the long point, or at least it should just barely touch it. If the long point dips into the gasoline, the level is too high and the float should be adjusted accordingly.

8—The best operation of the carbureter is secured at the  $1/16$ -in. level.

9—To raise or lower the level of the fuel, the float lever is bent up or down as the case may be. Fig. 76 shows the operations of lowering the level by bending or prying the lever up or raising the level by bending the lever down.

10—It is desirable to make the float stand at a slight angle away from the flange with that part of the float which is opposite the hinge farther from the



flange than the hinge section itself. The pressure of the gasoline will then be greatest at the extreme end of the float and this will insure a tighter fitting needle valve which will prevent leakage at this point.

11—In making the above tests on a car which has been used, the bowl should be drained and allowed to fill up again, as when an engine is stopped there is always a certain amount of condensation in the intake manifold which finds its way back into the bowl and thus gives an artificially high level.

12—See that the float lever is tight on the float and that the rivets and screws are not loose.

13—See that the float is central about the mixing chamber and that it is not twisted to one side or the other as it might rub on the stem or on the inside of the fuel chamber and any rubbing or contact of this nature would cause erratic action of the float and consequently the gasoline level would vary considerably.

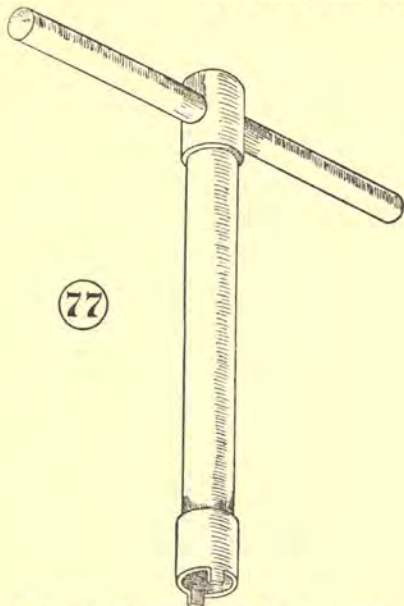
### The Holley Fuel Inlet Valve

The fuel inlet valve consists of a needle with a hard tip and this is lifted by the float as the fuel level rises until, when the level is correct, the tip of the needle enters the hole in the needle seat and so stops flow of gasoline from the tank until the level drops in the bowl.

1—For satisfactory operation, the needle must be true and without burrs or scratches and the seat must also be true so that when the needle touches the seat, a gasoline-tight joint will be made.

2—If either needle or seat is damaged, it is best practice to renew both parts as grinding is uneconomical and is not sure to produce a good job. The only excuse for grinding is lack of new parts.

3—The inlet needle seat is best removed with a special tool shown in Fig. 77, although it can be done with a screwdriver. The use of the tool, however, prevents burring and damaging the outside of the seat and the slot. The seat fits in against a gasoline-proof fiber



*Fig. 77—Special tool for removing and replacing the inlet needle seat on the Holley carbureter*

gasket. If this is torn or damaged during the removal of the seat, it should be replaced also, making sure that all of the old gasket is removed.

4—See that the needle seat is screwed in against the gasket.

5—Owing to the triangular shape of the needle body and the shoulders which guide it, there is a possibility that one of these shoulders might catch in the screw-driver slot in the needle seat when the float drops to the bottom of the empty float chamber. If the float chamber has been drained and floods upon again being filled, the needle can easily be jarred loose by a slight tap with a hammer or wrench on the side of the carbureter body.

6—The tightness of the fuel inlet needle may be ascertained by turning the carbureter upside down, allowing the weight of the float to hold the needle on its seat and then sucking lightly on the fuel inlet elbow. If the valve is tight it should stick to the tongue or

lips much the same as in the case of a small bottle.

### The Spray Nozzle

1—The spray nozzle is held down against a gasket by means of a thread on the lower end which extends down into the stem of the mixing chamber below the hole which admits the gasoline to the inside of the stem. It forms the seat for the needle valve and also embodies a cup into which the low-speed tube extends.

2—See that the nozzle is screwed tight down on its gasket. This is accomplished with a special slotted wrench shown in Fig. 78.

3—Check the size of the hole forming the needle seat. This should be a No. 52 drill, .063 in. diameter. The thickness of the disk through which this passes is  $1/16$  in.

4—Check the taper in the upper end of the needle seat hole. It should extend to a depth of between  $1/64$  and  $1/32$  in., and should be the same angle as the needle point, which is 30 deg. If

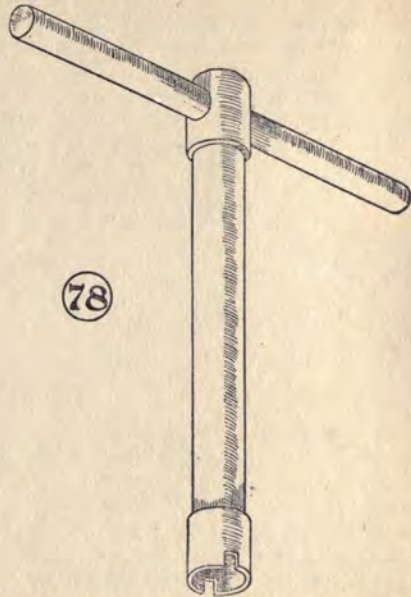


Fig. 78—Slotted tool for removing and replacing the spray nozzle on the Holley carbureter

the hole has been enlarged by screwing the needle in too far, the seat should be thrown out and a new one put in.

5—The needle hole and the four holes through the side walls immediately below the disk which forms the needle seat should be unobstructed.

### The Strangling Tube

The strangling tube is a die casting to give depression and mixing action above the spray nozzle and it is held on its seat by a spring wire at the top.

1—To remove the tube, take out the retaining wire and the tube can be lifted right out.

2—The older models had tubes with an inside diameter of 13/16 in., but the newer models are fitted with tubes of 23/32 in. diameter to more readily mix the lower grades of fuel on the market in the past two years.

3—Much better carbureter action can be secured if the larger tube on the older models is replaced with the new smaller tube. An old tube can easily be identified

by checking up the smallest inside diameter of the tube. The difference in carbureter performance will not vary much during hot weather, but there is a decided improvement in cold weather when the smaller tube is used.

### The Low Speed Tube

The low speed tube supplies gasoline for idling when the throttle is closed or only very slightly open.

1—See that the clamp nut at the upper end of the tube is tight.

2—See that the screw through the side wall of the mixing chamber to which the upper end of the tube is attached is tight.

3—The plug which fills the hole through which the low-speed tube is inserted must be tight.

4—The lower end of the tube must be tight against the small shoulder at the bottom of the cup in the spray nozzle, thus leaving a clear path for the needle valve to reach its seat.

5—The lower end of the tube is

beveled at a 7 deg. angle so that the edge nearest the spray nozzle is higher than the edge against shoulder in cup.

6—The lower edge of the tube farthest from the spray nozzle hole must be down to within 1/64 in. of the bottom of the spray nozzle cup.

7.—The tube must not be bent or dented.

8—The lower end of the tube is flattened, making a long narrow opening at the bottom. Be sure that this opening is not plugged up and do not enlarge it or change its shape as the original shape has been developed to give the best operation.

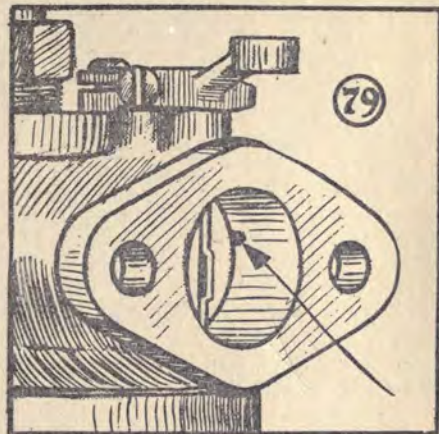
#### Low-Speed Hole in Mixing Chamber

When the throttle plate is set straight across the carbureter outlet, the edge of the low-speed hole in the mixing chamber should show from .02 to .04 in. outside of the throttle plate as shown in Fig. 79.

#### Throttle Plate, Rod and Lever

If the throttle rod or the holes in the

mixing chamber are worn sufficiently to make a loose fit, a new rod should be

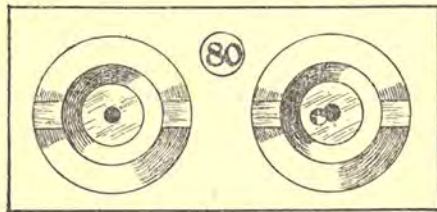


*Fig. 79—The low-speed hole should show between .02 and .04 when the throttle is shut on the Holley*

installed as looseness at this point will admit air from the outside and interfere

with satisfactory carbureter operation.

1—If the rod has a perceptible shake in the hole, replace it with an oversize rod, drilling or reaming out the hole



*Fig. 80—Result of the needle valve being out of adjustment. The spray nozzle is so damaged that it will have to be replaced and the point of the needle will no doubt have been hooked over*

in the mixing chamber to make a good fit for the new rod.

2—Standard oversize rods are 17/64 in. and 9/32 in., the original size of the rod being 1/4 in.

3—The plate when set squarely across the outlet hole of the mixing chamber

should not be less than .006 in. smaller than the hole. If there is more clearance than this the plate should be replaced with a new one that does fit or it should be peened with a hammer around the edges until it fits correctly.

4—When the plate is pinned to the rod, any clearance should be on the side nearest to the low-speed hole.

5—For pinning the plate to the rod, use a No. 55 drill .052 in diameter and have the pins fit tightly in the holes.

6—In adjusting the throttle lever for idling, set the clamp screw tight enough to hold the screw so that a screwdriver is required to turn it.

#### Assembling the Mixer Chamber Cap

1—The needle valve must register exactly with the hole in the spray nozzle.

2—To check this up, tighten the clamp-nut slightly, hold the cap between the jaws of a vise and turn the needle valve. There should be no sideways motion at the point. If the point is not true the needle is bent and it should be either straightened or replaced with a new one

3—Back the needle valve up several turns before putting the cap in place to prevent possible damage to the point or the seat. Fig. 80 shows damage done by bent needle.

4—Put the cap in place.

5—Attach the cap to the mixing chamber with the three screws, drawing them down equally so that the cap presses evenly on the gasket at all points.

#### Setting the Kingston Float

Three models of Kingston carbureters have been used on Fords as indicated—

1913-1914	Model Y
1915-early 1916	Model L
1916-1918	Model L-2

Each of these has a different float setting:

1—On the Model Y the clearance from the top of the float to the top of the float chamber should be  $9/32$  in.

2—On the Model L the clearance from the top of the float to the top of the casting should be  $9/32$  in.

3—On the Model L-2 the body must be turned upside down to check the float level and there should be a clearance of  $7/16$  in. from the top of the float to the top of the machined surface on the cup casting. In this model the float is hinged directly to the body instead of being pivoted to the cup, as in the two former models.

4—In many other respects the same precautions that are used in overhauling and assembling the Holley carbureter are applicable to the Kingston. The only radical change in construction is the air valve which rests on its seat when the engine is stopped or running slowly. As the speed of the engine increases, this valve rises and permits more air to pass.

5—The gasoline level is at all times above the fuel nozzle so that a tiny pool of gasoline is formed in the lower part of the mixing chamber. When the engine gets up speed, this pool is used up and the gasoline comes directly from the fuel nozzle.

## CHAPTER XVII

### Assembly of Engine and Transmission

**I**N going over the various operations that have preceded this, we find that certain parts of the engine have been partially assembled in the process of overhauling. In the preparation and burning-in of the bearings, for instance, the pistons, rings and other details were all attended to before the burning-in took place, so that these parts would not afterward have to be taken out. The connecting rods and bearings are all supposed to be properly fitted and in their right places, the camshaft and camshaft bearings have been fitted, the camshaft gears properly timed, the flywheel assembled to the crankshaft, the oil pipe in place and the transmission assembled so far as the drums, clutch, etc., are concerned.

#### Magneto Clearance

When the main bearings were fitted by the burning-in process, the ends of the rear main bearing were also fitted to

the crankshaft so that there would be no more end motion to the crankshaft than was absolutely necessary for the shaft to turn easily. If there is end motion, it will be impossible to maintain the magnets and the spools in the proper relation to each other and the result will be that when the shaft backs up the magneto distance will be increased with a consequent reduction in the current delivered by the magneto, and when the shaft moves forward the voltage will be greatly increased and the danger of burning out the lamps and pitting on the coil contacts will be much greater.

When assurance is had that there is no end motion to the crankshaft, the distance between the cores of the spools and the magnets should be definitely set so that there is a gap of exactly  $1/32$  in.



1.—This distance is changed by altering the number of magneto-coil support shims (Part No. 3272).

2.—These are shown in Fig. 81. They are made of sheet steel and increasing the number of shims decreases the magneto gap, while decreasing the number of shims increases the magneto gap.

3.—This distance is to be measured after the bolts have been set down tight.

### The Crankcase Nose

Before assembling the lower crankcase to the block, see that the nose is in proper condition.

1.—The rivets should all be tight.

2.—The brazing should be intact if the part is brazed.

3.—If the crank handle is loose in the bushing so that it rattles, it should be replaced with a new one.

4.—Drive the old bushing out.

5.—Insert the new bushing.

6.—Ream out the hole with the reamer shown in Fig. 82. This is the steering-bracket bushing reamer, but it is the

same size as the starting crank and is, therefore, used for this purpose.

7.—Put the starting crank in place in the bushing, first having slipped the spring in place. The spring can be slid

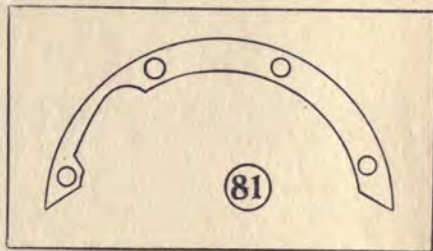


Fig. 81—Magneto coil support shim

down on the bend of the crank to facilitate matters in putting the ratchet and pin in place.

8.—Put the ratchet in place.

9.—Insert the pin and rivet the ends so that it cannot fall out and so the ends do not extend out more than necessary.

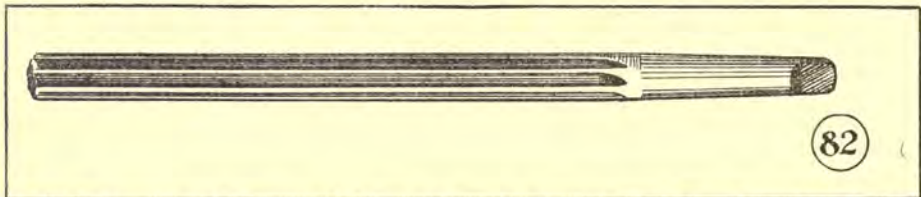
10.—Put the spring in its place.

### Replacing and Grinding Valves

1.—The push rods should have been examined previous to the installation of the camshaft, and if they are worn so that they would rattle or tend to change the timing of the valves, they should be

far outdistance fiddling with the old ones.

3.—The valves should be ground with a fairly thick mixture of powdered emery and thin oil, such as is ordinarily used for lubricating the Ford engine. This



*Fig. 82—Steering bracket bushing reamer which is used for reaming the starting crank bushing*

replaced with oversize push rods, reaming the holes with the oversize reamer which is provided for the purpose.

2.—In an engine overhaul, it is best to take no chances with the valves, particularly if the seats and ports have been reamed out, as the cost of new valves is so small that new ones will

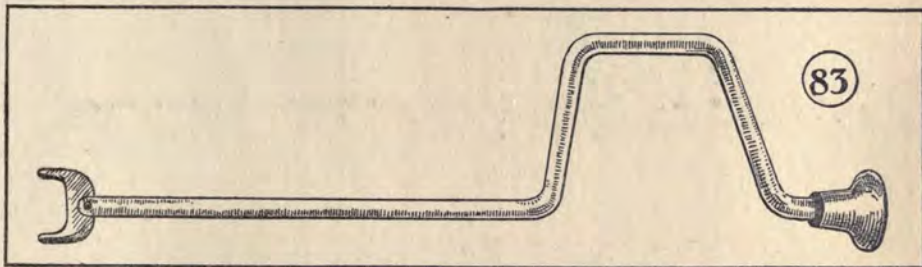
should be mixed so that it is not so thin that it will run down into the ports, and it should be used very sparingly.

4.—When grinding a valve be sure that the camshaft is in such a position that the push rod is all the way down or on the heel of the cam. If the cam is up, the valve will simply turn around

on the push rod and the seats will not touch each other.

5.—Use a valve grinder such as is shown in Fig 83. It is much easier and quicker than the short ones that are

6.—In grinding the valves, use an oscillating motion or a swing back and forth, covering a little more than half a circle each time. Every few swings change the position of the valve and lift



*Fig. 83—Valve grinding tool for ordinary shop work*

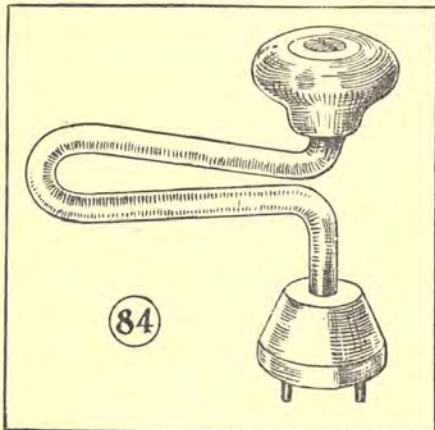
used by owners. However, when the valves are ground with the engine in the car, the clearance on the last two valves is so small that it will either be necessary to use a short grinder like Fig 84 or one with a universal joint like Fig. 85.

it up a little so that fresh grinding compound will get under the seat.

7.—A handy time-saver for this purpose consists in cutting an old valve spring so that it is just long enough to raise the valve about  $\frac{1}{4}$  in. from its seat when the pressure is taken off. A dia-

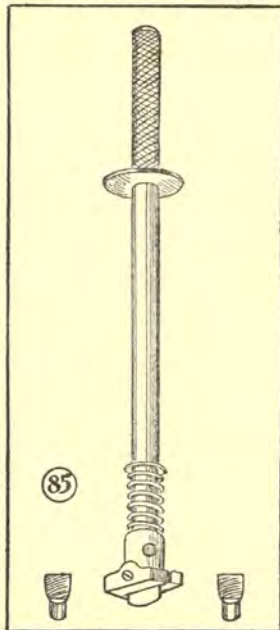
gram of this device is shown in Fig. 86.

8.—A good seat is obtained when there is an unbroken white line all around



*Fig. 84—Short valve grinder for fourth cylinder under dash*

both the valve and the seat. It is not necessary that the line be wide, in fact, a better seat is obtained with a very nar-



*Fig. 85—Valve grinder with universal joint*

row line. Neither is it necessary to have a high polish on the seat or valve.

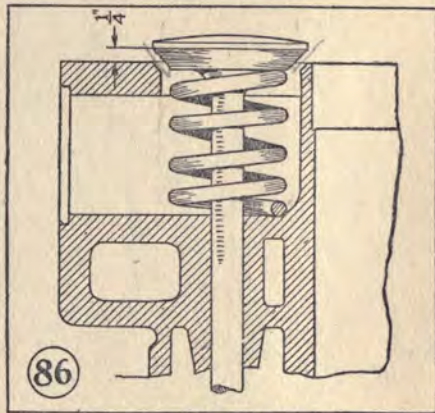
9.—If the valve shows white on one side only, this is evidence that it is bent, and it should be replaced with a new one rather than trying to straighten it. If only slightly bent, it may be straightened by hitting it a slight tap with a hammer when it is on the seat.

10.—If only one side of the seat shows the white line, the seat is warped or distorted and should be reamed out with one of the valve reamers shown in a previous chapter.

11.—After a perfect seat is obtained, remove all the abrasive and wash the surrounding parts with gasoline to remove every particle of emery so that there will be no chance of its getting into the cylinder or down into the valve guides.

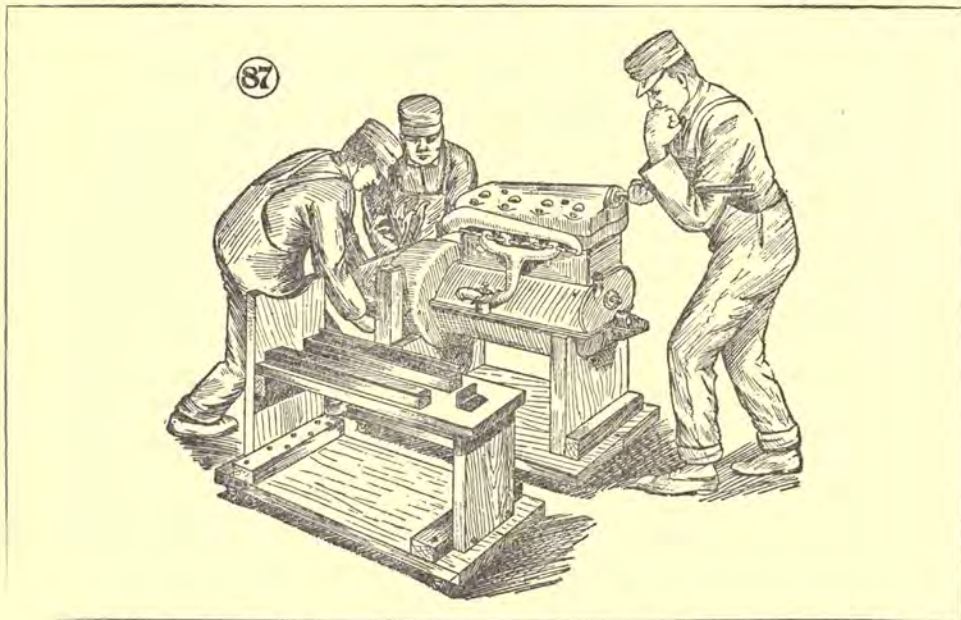
12.—The clearance between the lower end of the valve stem and the top of the valve should be checked up. The minimum distance is  $1/64$  in., and the maximum distance  $1/32$  in. The clearance

should be kept as close as possible. If the valve is too short, it is recommended that a new one be used rather than try-

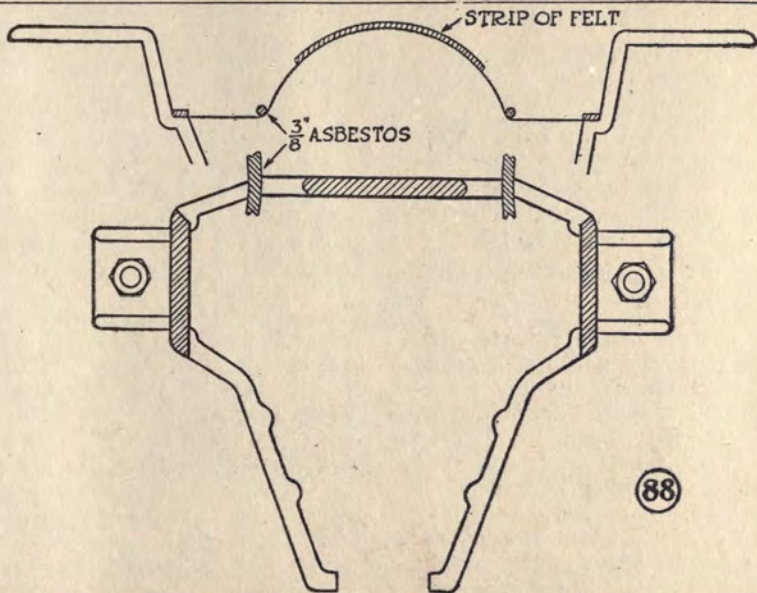


*Fig. 86—Spring cut off to lift the valve off the seat when grinding*

ing to draw it out by peening, as the expense and trouble are not worth the difference, and a valve that is not peened



*Fig. 87—Method used in turning the engine over. This requires three men*



88

Fig. 88—Double packing at certain points between the transmission cover and the crankcase prevents oil leakage at these points

is liable to last much longer than one that is peened.

13.—In case of a valve too long, it should be filed off, keeping the end of the stem absolutely square.

14.—The valves are then put in place with the springs and cups in place and the pins inserted in the stems with the use of a valve lifter, just the reverse of the method of taking them out.

#### Assembling the Crankcase and Transmission Cover

1.—Felt gaskets were formerly used between the crankcase and the block and between the crankcase and the transmission cover, but these have now been replaced with cork gaskets to a large extent. These parts are furnished standard from the factory or branches.

2.—Either shellac or cup grease may be used to coat the gaskets when assembling, but most of the larger stations and branches now use a heavy grease.

3.—Stand the cylinder block on its head on the upside-down engine stand.

4.—Put the crankcase gaskets in place with grease.

5.—Put the crankcase in position on top of the block.

6.—Insert four or six of the crankcase bolts, putting them through from the bottom of the crankcase to the top, so that the nuts will be uppermost when the engine is in its upright position. The nuts should be started on all of the bolts and the speed wrench used to tighten them up.

7.—The head of the right front bolt under the timer is just opposite, or with the head up and the nut down, as there is not room for the nut on top without shortcircuiting the No. 3 terminal of the timer when it is put in place.

8.—After the bolts are all tightened up evenly and as tight as possible, the cotters should be inserted.

9.—Turn the engine over onto the other engine stand. The turning is easily accomplished by inserting a bar in the outlet water hole on the cylinder head. One man can catch this in his



elbow to act as a pivot and two other men can pick up the transmission end of the engine, turning it right over. For convenience, the two stands should be side by side and close together. See Fig. 87 for the method of doing this. This is only possible, of course, when the cylinder head is bolted in place.

10.—The gaskets between the transmission cover and the crankcase require a little more care and there are certain points as shown in Fig. 88 that require

a double thickness of packing to prevent leakage of oil at these points.

11.—The lugs on the bands are still assumed to be held together with the U-shaped piece shown in a previous chapter, and the transmission cover can then be slipped into place by jiggling the pedals around a little till they drop down in the right place.

12.—Remove the U-shaped piece after the transmission case bolts have been inserted and tightened up. If any diffi-

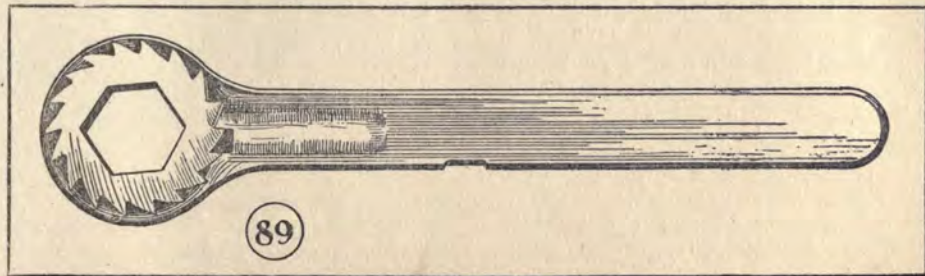


Fig. 89—Reverse and brake pedal tension spring ratchet wrench

culty is had in lining up the bolt holes, a tapered drift pin will soon bring them into line.

13.—In adjusting the clutch and brake, a ratchet wrench saves a great deal of time over a solid wrench. This is made especially thin so that it can be easily put in or taken out. This is shown in Fig. 89.

14.—The slow speed band is adjusted by loosening the lock nut at the right side of the transmission cover and turning the adjusting screw to the right.

15.—To tighten the brake and reverse bands, the transmission cover door is removed and the adjusting nuts turned to the right. The bands should not drag on the drums when disengaged as this will act as a brake and not only use up

power, but produce a heating effect and also wear the linings.

16.—The foot brake should be adjusted so that a sudden pressure will stop the car immediately or slide the rear wheels in case of an emergency.

17.—Replace the transmission cover door, using a new gasket.

The only parts now necessary for the complete assembly of the engine ready to put it on the test stand are the timer, the cylinder head, the fan with its belt and other apparatus, the valve cover doors and the manifolds. New gaskets should be used all around, and especially on the manifold, as a leak at this point will result in poor engine operation, especially at the intake.

## CHAPTER XVIII

### The Ignition System

**A**SIDE from the magneto, which was fully covered in a previous chapter, we have to deal with the coils, vibrators, plugs, timer or commutator, wiring and switch.

The coil box containing the four coil units is fastened to the rear of the dash and is not subject to trouble ordinarily unless in case of accident or grounding of some part of the connections. When the units are slipped into place, the proper contacts are automatically made with the wiring by means of the spring contacts. If there is not a good electrical contact, the springs either do not press sufficiently hard against the contacts or the metal has become corroded and should be scraped clean.

The spring contacts in the coil box connect with the porcelain insulators which extend through the dash over the engine. Sometimes these get broken, in

which case the current from the high tension leads of the units is liable to escape to the dash or some other point and so put that lead out of commission.

Sitting in the driver's seat and looking toward the front of the car, the coil unit to the left is numbered 4 and is connected with No. 4 spark plug from the bottom terminal and No. 4 contact on the timer from the upper terminal. From No. 4 unit at the left the figures run, reading toward the right, 3, 2 and 1, each of which connects with a similarly numbered spark plug and contact on the timer, the bottom or high tension wires going to the plugs and the upper or low tension going to the contacts on the timer through the 5-way assembly.

The entire electrical system on the Ford, including ignition, lights and horn, has a grounded return, or in other words is a one-wire system. The single pole



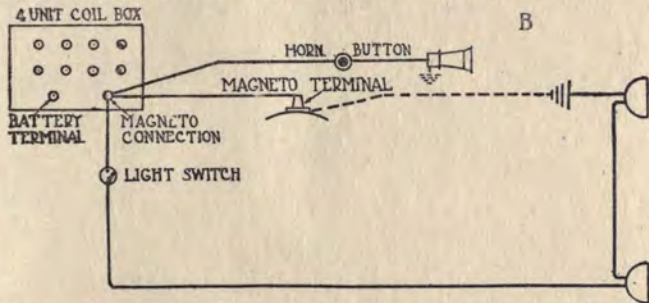
tact, the red to the No. 2 in each case and so on for the others.

In overhauling the wiring, observe the following points:

1—Examine the wiring and if it is oil

2—See that connections are clean and tight, scraping the metal if necessary to secure a good metallic contact.

3—Look out for broken wires, worn insulation, mixed wires at the terminals,

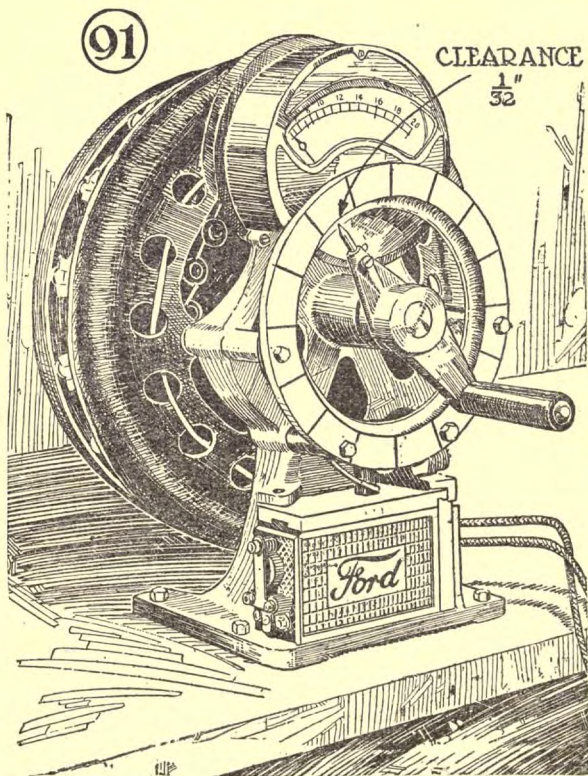


*Fig. 90B—Wiring diagram of Ford, showing the lighting and horn circuits. Note that this diagram does not apply to cars equipped with the Ford electric starting and lighting system*

soaked, frayed or otherwise in damaged condition, replace it with new wiring. This is furnished cut the correct length, in loom where necessary and all furnished with the necessary terminal connections.

wires so attached that the timer wires touch the gear cover, loose strand touching the gear cover or commutator case.

4—Consult the wiring diagrams in Figs. 90A and 90B,



*Fig. 91—This coil-unit testing machine is used for testing the units and adjusting the vibrators to the best possible position*

### The Coil Units

When any considerable quantity of Ford coil units have to be tested and adjusted, the use of a coil-unit testing machine shown in Fig. 91 is strongly advised. This consists essentially of a Ford flywheel with its assembly of magnets, the whole being revolved by means of a crank handle. The coil assembly is held stationary as in the case of the Ford engine and the magnets passing before the coils produce exactly the same current as in the engine. The current is conducted through wires to contacts which connect by springs to the coil unit when one is inserted in the receptacle provided for it. The high tension current is then conducted on one side to the ring surrounding the crank and on the other side to the pointer which is opposite to the crank and which revolves with the crank.

Presuming that a unit is in place,

1—Turn the handle around at a moderate rate of speed.

2—Adjust the vibrator screw in or out, as the case may be, till the vibrator buzzes.

3—The most perfect adjustment is obtained when the spark is seen in the form of a circle passing between the pointer and the ring.

4—If the spark only appears at a few points on the circle, the adjustment is not correct and should be changed. The more nearly the sparks assume the shape of a circle around the ring, the more sparks there are passing at the points of the plug when the unit is in place on the car and the more perfect the ignition. A smaller number of sparks reduces the possible chances of firing the mixture.

5—If it is impossible to adjust the unit so that it causes this circle of sparks, there is something the matter with the unit.

6—The points of the vibrator may be burned or not trued off correctly so that it is impossible to secure a satisfactory contact. In such case, the points should be either dressed off, or if they are badly

burned, should be replaced with new ones.

7—If it is impossible to secure any spark or any buzzing at all, there is either a broken connection in the coil or the condenser is punctured.

8—A punctured condenser may short circuit the primary so that the coil will not operate at all, or it may be punctured in such a way that the leaves do not short circuit each other, but simply allow excessive sparking at the contact points.

9—The best remedy for a damaged unit is to replace it with a new one.

10—The voltmeter on the machine is used to check up the voltage given out by the magneto. At normal speeds it should give about 18 volts. It should be possible to produce a spark at the points when the machine is running so slowly that only 6 volts are being produced.

11—Another cause of trouble is moisture in the coil units. This may possibly be remedied by a slow drying out. It should not be remedied by putting the

unit in a very hot place, such as an oven, as this will only melt the insulating compound in the unit and more trouble will result.

### Spark Plugs

The best and quickest way to conduct repairs on spark plugs is to put new ones in where there is any doubt about their performance. The small expense involved will be repaid in the better running of the engine, and any faults that develop in the test can be better and easier located if the repairman is sure that the plugs are all right.

1—In case of doubt about a plug, the trouble will either be a short circuit from carbon on the lower part of the insulator, a short circuit from a broken or cracked porcelain or incorrect gapping of the electrodes.

2—If the plug is otherwise perfect, the carbon can be cleaned off the porcelain by unscrewing the compression nut and wiping the carbon off with a rag soaked in gasoline. If the carbon does not respond to this treatment, it may be

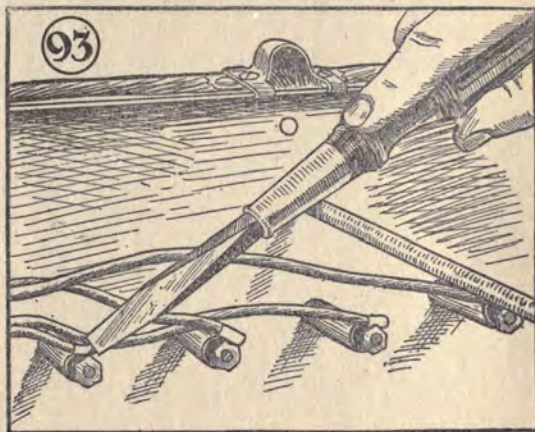


scraped off, but care must be used not to scrape the glazed surface off the por-

3—In reassembling the plug, be sure that there is no dirt or grit and set the



*Fig. 92—Spark plugs are tested with a screwdriver by shorting them to the cylinder block*



*Fig. 93—The terminals of the coil units can be conveniently shorted to the radiator stay rod with a screwdriver*

celain, as this will allow the carbon to accumulate more rapidly at this point

nut up tight so that the porcelain makes a tight fit against the gaskets. Leakage

at this point can be tested when the plug is in the engine by pouring a few drops of oil around it. When the engine is running, bubbles will appear if there is a leak.

4—A broken porcelain is usually evidenced by the upper part of the porcelain being loose. It usually breaks just at the lower part of the stem.

5—A cracked porcelain can sometimes be identified by looking at the plug in a dark place when the current is passing through. A leak will show up by the spark jumping through it at this point.

6—The electrodes should be clean and should be gapped about  $1/32$  in. This is about the thickness of a worn dime. If the construction of the plug admits, the electrodes should be bent so that the oil will run away from the gap by gravity and not down to the gap.

7—The size of the plug is  $1/2$ -in. pipe thread which has a taper of  $3/4$  in. to the foot, so that when the plug is screwed in it forms a tight joint without the necessity of a gasket. The length of

the plug should be such that the electrodes just extend down into the combustion chamber. If a plug has been designed so that the hexagonal part of the shell extends pretty well up, this will facilitate easy removal and replacement.

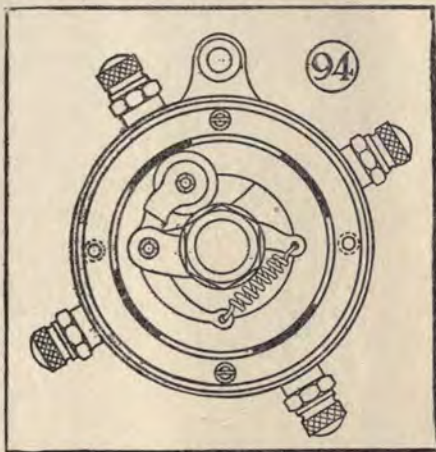
8—While plugs can be tested with a 6-volt current from a battery, the most accurate tests are secured by using the testing machine which produces just exactly the same current as the magneto in the Ford engine.

9—Methods of testing the plugs and coil terminals by shorting them one at a time are shown in Figs. 92 and 93.

### The Timer

The timer is probably the cause of as much trouble as all the rest of the ignition apparatus put together, and the trouble is mainly due to improper care on the part of the owner. The timer should be lubricated regularly and frequently with very light oil and if it is neglected, there is an accumulation of

gummy oil that covers the contacts and it is difficult if not impossible to get



*Fig. 94—The Ford timer, with the shell removed to show the parts*

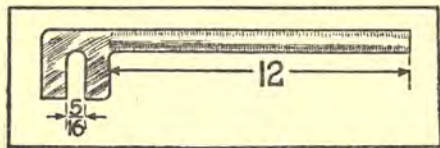
the current to pass across this gap. Regular oiling is the only way to keep the timer working correctly.

determines very directly the wear on the parts and consequently the life of the timer. When not lubricated, parts of the shell wear and other parts wear more slowly so that the shell does not present a true circle. The result is that when the engine gets to running at any fair rate of speed, the roller jumps over some of the contacts, and the units connected to these missed contacts fail to buzz, consequently that cylinder misses. This is a particularly frequent trouble.

1—The quickest and best remedy for this is to replace the timer shell with a new one and also replace the roller and arm if there is any wear apparent. It is difficult and expensive to turn the timer shells out and the tool usually jumps into the soft fiber so that it is practically impossible to turn the timer shell out to a true circle. Grinding will produce a true circle, but usually the expense of setting up the parts is out of all proportion to the ends attained.

2—The roller should press against the shell with sufficient force to make a good

ments. Sometimes the arm becomes bent and in such a case it should be bent back to its correct position. When the timer shell is taken off, the roller should extend to a point about  $\frac{1}{4}$  in. further out than the inside circle of the shell. A screwdriver placed under the roller as shown



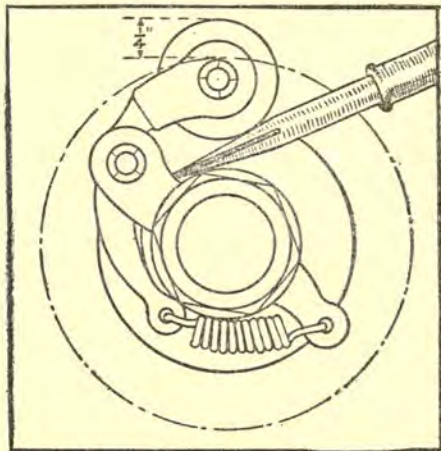
*Fig. 96—A bending bar for bending the timer pull rod*

in Fig. 95 will bend the arm out to this position.

3—The commutator pull rod not only advances and retards the spark, but is also the adjustment as to the timing of the spark as related to the spark lever on the steering wheel. The shorter the rod, the earlier the spark, and vice versa. If the rod is bent, therefore, it will be shortened.

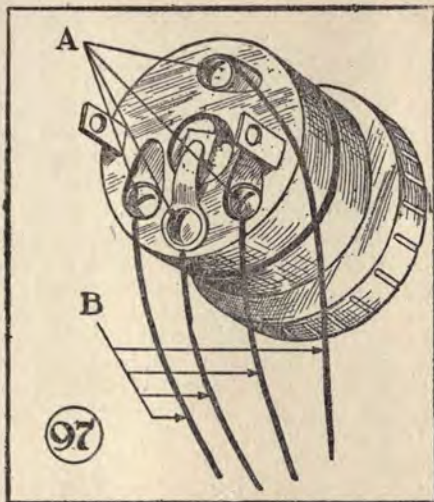
A tool to make the quick and easy

bending of this rod possible is shown in Fig. 96.



*Fig. 95—The roller arm can be pried out with a screwdriver*

4—The ordinary troubles that may be looked for in the switch are shown in Fig. 97.



*Fig. 97—The switch may cause trouble. A shows possible loose or poorly made connections shorting into switch housing. B shows possible wires grounding at point of entering switch housing or conduit on steering column*

Where the wiring is at all ragged or soaked with oil or water, it should be replaced. In replacing wiring, it will save much time to use the standard Ford wiring assembly in which the wires are all cut to the correct length. The wires are all furnished with terminals and are the proper color in every case so that they can be connected up by anyone with the assistance of the regular wiring diagram.

The terminals should all be tight, but care should be exercised not to pull the nuts up so tight that the stems will be broken off. As a general rule, set them hand tight and then give them a half turn with a pair of pliers. This will prevent any of the terminals from coming loose.

As far as possible, arrange the wiring so that the terminal points in the direction that the wire is to take. This will prevent making awkward bends in either the wire or the terminals, as these turns are liable to break under vibration. As an extra precaution, see that all the connections are bright and clean and, if they are not, scrape them till they are.

## CHAPTER XIX

### Testing the Engine

**T**HE completion of all the overhaul operations described in the previous chapters now leaves the engine and transmission ready for running-in and testing. In order to carry out this work, some kind of a stand must be used to hold the engine rigidly in place and the stand should be fitted up so that the engine can be quickly fastened in place and connected up so that as little time will be lost in this operation as possible. One of these is shown in Fig. 98.

The stand will serve two purposes, running-in and testing.

1—Three quick clamping devices are required, two at the rear engine supports and one at the front engine bearing. These consist simply of U-shaped loops riveted or bolted to the stand and having hand screws to tighten the arms against the stand. When they are unscrewed a little way, the loop can be thrown back

and the engine lifted out. In lifting the engine in and out of the stand, use the engine tongs which were described and illustrated in the early chapters.

2—After clamping the engine in position, the water connections must be connected to some source of water supply. This can either be city pressure in which a small quantity of cold water from the city mains is allowed to pass through the water jackets, or a hopper system shown in Fig. 99 in which the same water is used over and over until it evaporates or gets dirty, in which case it is renewed.

3—The hopper system is to be preferred as it makes testing conditions as nearly like actual operating conditions as possible.

4—Install a boiler or tank of about 40 to 50 gal. capacity on a stand in such a position that the lower end of the boiler

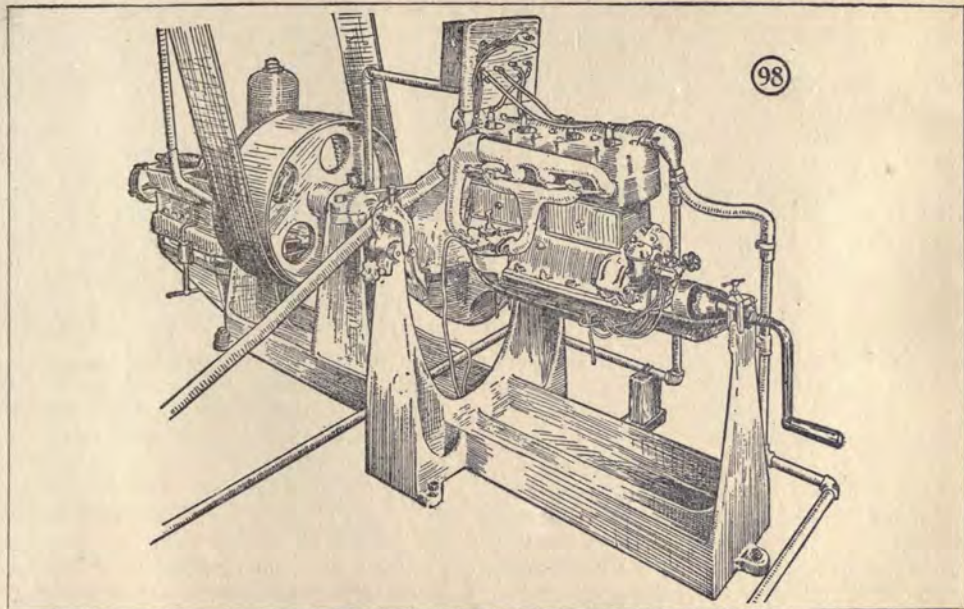


Fig. 98—One type of engine testing and running-in stand in which the belt supplies the power from an outside source

will be below the level of the lowest point of the water jacket of the engine when it is in place on the engine stand. The boiler should not be more than 6 or 8 ft. away from the engine.

5—Two water connections are to be made in the boiler, using at least 1 in. pipe connections to secure a sufficient flow of water to allow for proper cooling. One of these is made near the bottom of the boiler and is connected to the inlet water connection of the engine, the other being made at a point in the side of the boiler about 8 in. above the level of the outlet water connection of the engine when it is in place on the stand. This is connected to the outlet water connection.

6—The top of the boiler is left open, either removing the pipe plug which is usually a stock fitting on a boiler or else cutting a hole about 2 in. in diameter at this point. This opening is to permit the escape of steam and to allow a water gage to be installed so that the operator can know at all times how much water there is in the boiler.

7—The proper amount of water to carry in the boiler will depend on the temperature of the air, hot weather requiring a larger amount than cold weather.

8—Another connection can be fitted for filling the boiler from the city supply when such filling is necessary or else the water can be put in through the opening in the top. The gage mentioned in the previous paragraph is shown in a general way in Fig. 99, but this may be altered to suit the fancy.

9—When the connections are completed, the water will have a natural circulation through the water jackets of the engine and the boiler and the engine will be cooled, but will run at a temperature near the boiling point of water which is the proper temperature to run and test the engine.

10—If the city pressure is to be used in cooling the engine, cocks must be inserted in the line to control the water as too much will make the engine run too cold and will not allow of proper testing.



A convenient way is to have two cocks in the supply pipe, one a globe valve which has a screw handle and the other a lever

handle. The screw handle can be regulated to allow the right amount of water to pass, then simply opening or shutting

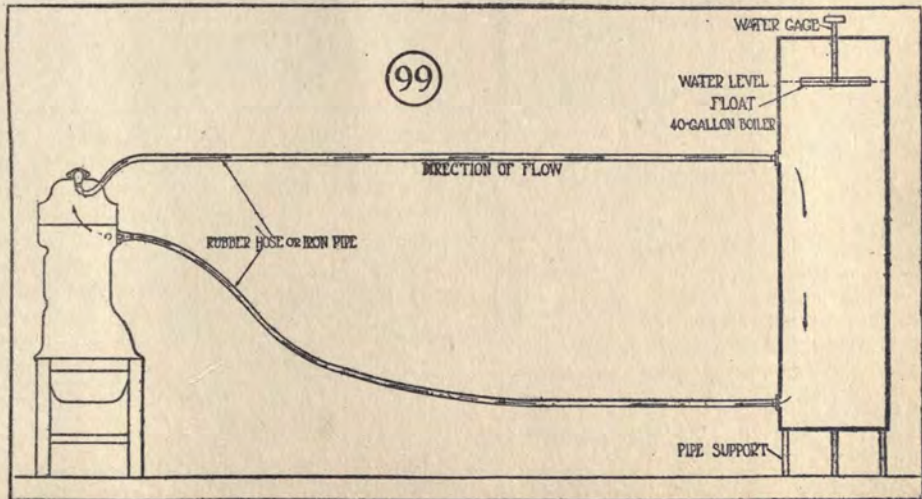
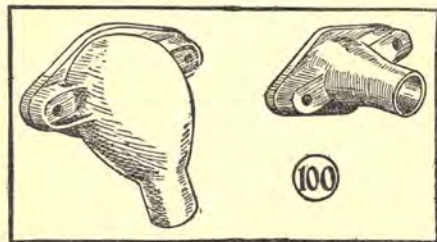


Fig. 99—Diagram showing the water connections for the hopper system of cooling

the lever handle will allow the water to pass or cut it off and it will not be necessary to make the adjustment every time



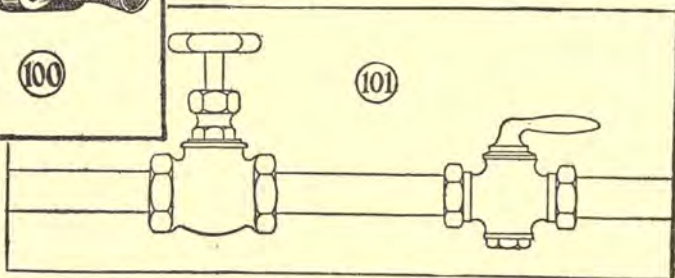
*Fig. 100—Details of inlet and outlet water connections for testing*

the engine is started up or a new engine put on the stand. This arrangement is shown in Fig. 101.

11—The special water connections to be used with either of these two methods are shown in Fig. 100. The rubber hose

fits tightly over the end and is secured with a hose clamp.

12—An important point in the installation is the piping of the exhaust. This should be piped to the outside air by all means, as the exhaust is not only disagreeable, but highly poisonous and will



*Fig. 101—Two cocks installed on the water line permit of quick action*

have a very bad effect on the workmen in the shop. It is quite an easy matter to make up a permanent exhaust pipe from the testing stand to the outside air, using

a regular Ford exhaust pipe and pack nut to make connection with the engine to be tested. As this pipe gets quite hot, it should not be allowed to come in contact or near any wood, oil, grease, or anything else which would be liable to take fire from the heat. It should also be so protected that workmen will not get burned on it.

13—After the engine is run-in, which will be covered later in this chapter, it will be necessary to run the engine under its own power for a time to discover whether there are any faults in any of the parts and also to limber it up a little. For this purpose, in addition to the water and exhaust connections, it will be necessary to hook up the ignition and the gasoline. The general practice in the matter of ignition is to have a set of coils attached to some kind of a swinging support close to the testing stand. The wire is maintained on this test set of coils, and it is only necessary to connect the proper wires to the timer, the magneto contact to the magneto terminal

and the cables to the spark plugs. The engine being tested will then generate its own current, using the timer which will be left on the engine. When the engine is to be taken off the stand, the wires are simply unhooked and the support with the coils on it swung back out of the way.

14—The supply of gasoline for testing the engine is taken from a small tank, holding a gallon or less, a regular feed pipe and connection being left on the tank so that it can be quickly attached to the carbureter. Some engine testing stands have a tank as part of the regular equipment.

### Running the Engine In

The engine should be run-in from outside power for a period of from 1 to 2 hr., or until it has lost most of its stiffness. Here are some suggestions for use in connection with running-in:

1—Fill the crankcase with oil to the level of the top cock and then add about 1 qt. more.

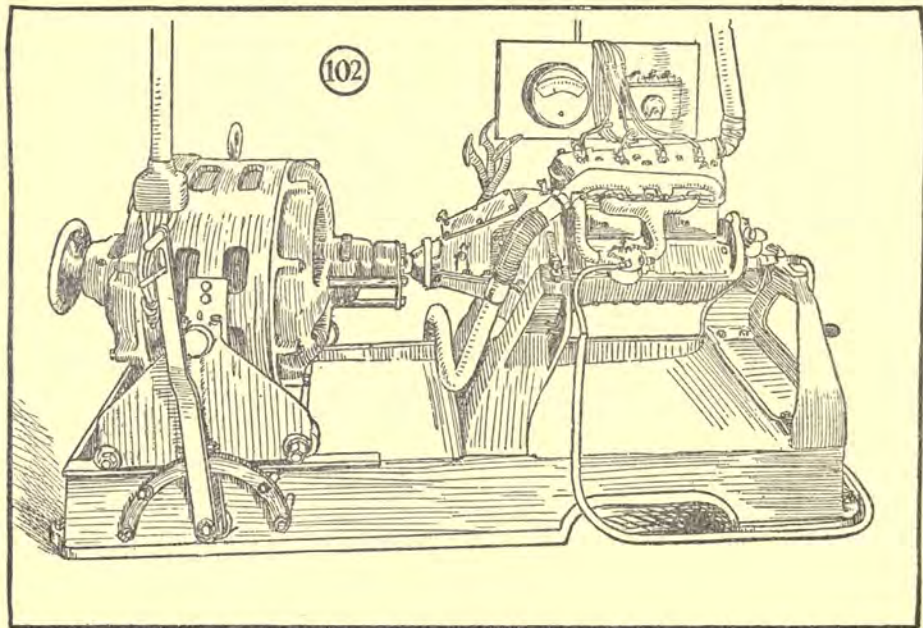


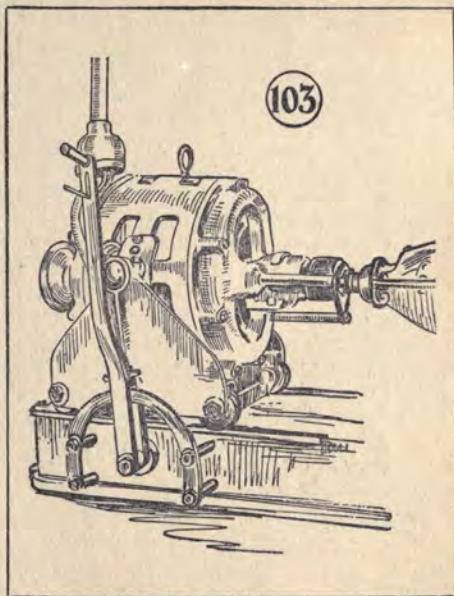
Fig. 102—An electric motor rigged up in connection with an engine testing

2—Squirt a generous quantity of oil in on top of the pistons through the spark-plug holes and souse plenty of oil on the valves, tappets, pedal mechanism, etc.

3—If a combined test stand and burning-in stand is used, the power from the belt is used and this should be applied gradually at first so as not to put too much strain on any particular part that may be stiff or may not yet have gotten its supply of oil from the lubrication system.

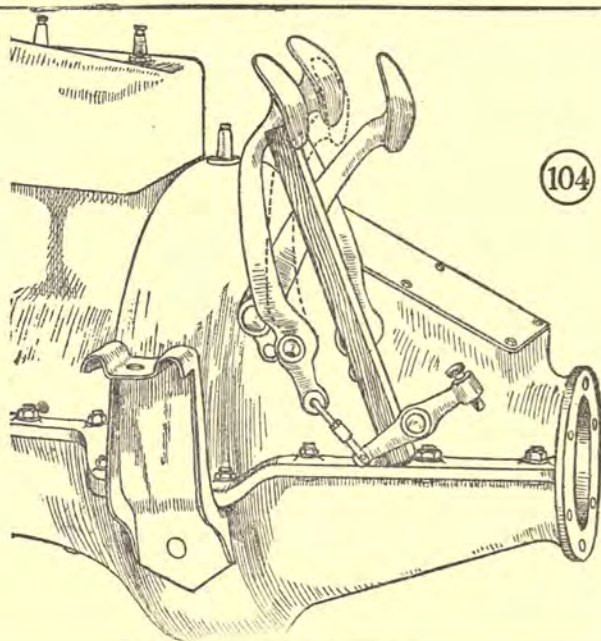
4—If a separate engine testing stand is used, apply the power in whatever way it is intended to be applied. Fig. 102 shows an installation which combines a testing and running-in stand with an electric motor which is used to start up and run the engine. As soon as the engine runs under its own power, the motor is shifted back out of the way and the current cut off. Fig. 103 shows detail.

5—After running under outside power for about 1 hr., shut off the power and try to turn the engine over with the hand



*Fig. 103—A close up view of the motor shifting mechanism*

*Fig. 104 — The clutch is held in neutral with a block of wood which is cut the right length to go between the crook on the pedal and one of the crankcase bolts. This block should hold the pedal out about 2 in.*



crank. Experience will tell when the bearings and other parts have loosened up enough to start running the engine under its own power. It should be possible to lift the crank without too much exertion.

6—The gasoline can now be turned on and the switch thrown on and if the carbureter is given approximately the correct adjustment at the needle valve the engine should start. If it stops after the outside power is thrown off, then there is either poor compression, a bad mixture, or the engine is still too stiff.

7—After the proper remedy has been applied for this condition, run the engine under its own power for a period of from 1 to 2 or 3 hr. It should be stopped at intervals after the first hour and tested with the hand crank. As soon as the engine can be cranked without too great difficulty, the test can be terminated as it will loosen up a good deal in the first few miles of running after it is installed in the car.

8—While the engine is running and

during the test, the clutch may be held in neutral by cutting a block of wood to fit between the clutch pedal and one of the crankcase bolts as shown in Fig. 104. The clutch should be out about 2 in.

9—While the engine is running under its own power, the clutch, reverse and foot brake should be tested. This can be done by manipulating the pedals by hand. For instance, holding the clutch in neutral with the block,

10—Push in the reverse pedal. It should turn the shaft at the rear end of the engine in the opposite direction without any noise.

11—Push the clutch pedal all the way forward and try the low speed.

12—While one of the gears is in, apply the foot brake slowly and see that it takes hold and slows down the engine.

### Engine Noises

During the test the operator must watch out for unusual noises which would tend to indicate something wrong with the assembly.

Here are some things that may happen:

1—Bearing knocks. Either main or connecting rod, caused either by bearings which have not been burned in properly or through oil not getting to the bearings as soon as the engine is run on the stand.

2—Knocks caused by pistons or rings sticking and seizing in the cylinders. This is caused by pistons which are too tight or rings which have not been filed off enough at the lap joints. Sometimes this can be remedied by running-in a little longer with an extra supply of oil at the places which bind.

3—Timing gear noises. These might take the form of a grind, indicating that the timing gears are meshed too tight or a gear rattle, indicating that the gears are meshed too loosely. There is really nothing that can be done with gears that are meshed too loosely excepting to tear down the engine again and do the job properly. A slight grind may disappear after the engine gets worn a

little. This is especially true with new gears.

4—Valve noises may be caused by improper clearance between the tappets and the valve stems. If the engine misses, and the missing can be corrected by inserting the blade of a screwdriver between the coils of any one of the valve springs, this indicates that the particular spring is weak and it should be replaced with one which has the right amount of tension.

5—Improper timing of the valves would be indicated by a refusal of the engine to start or by impossibility of keeping it running after it was started. This can be roughly checked up by taking out the No. 1 spark plug and noting whether the piston is at its top stroke when the exhaust valve just closes and the inlet just starts to open. The piston should rock on top stroke between these two valve positions. If the first cylinder is right the others are bound to be right. The timing of the ignition is very simple and the adjustment of the



pull rod was taken up in the chapter on ignition.

6—Loss of compression, evidenced by lack of power, may be caused by leaky valves, leaky rings or leaks around the spark plugs or cylinder-head gasket. The latter two can be checked up by dropping a little oil around the plugs and the edges of the gasket. Leaks will be evidenced by bubbles through the oil in the case of slight leaks or by forcible blowing out of the oil in the case of bad leaks. Apply the proper remedy in either case.

7—Compression leaks through valves or around rings can be tested by pulling the crank handle slowly against compression for one cylinder at a time. As a rule, the compression can be heard leaking out in addition to the ease with which the crank handle can be pulled up.

8—A defective cylinder-head gasket or a crack in the cylinder may allow water to enter the cylinder. This will be shown by an accumulation of water on the points of the plug in the defective cylinder. Water in any considerable

amount will cause missing through the water short-circuiting the plug, but a very slight amount may be turned into steam while the engine is running and is hot, so that a slight defect would not be noticed until after the engine has cooled off a bit.

9—After the engine has been run in and tested, the oil should be drained out, the crankcase washed out with kerosene and a fresh supply of oil put in the crankcase, filling the level to the top cock, and then adding about  $\frac{1}{2}$  pt. This will give ample lubrication to the rebuilt engine and at the same time it will not be excessive so as to cause fouling of the plugs. The owner should be cautioned to keep the level of oil right up to the top cock, especially during the first 200 miles. Carrying the level near the lower cock means more rapid wear and a hotter running engine.

10—In testing the engine on the stand, a timer advance device can be rigged up out of an old timer pull rod to hold the timer in the desired position.

## CHAPTER XX

### The Radiator

A FORD radiator brought into the shop for repairs is usually in such bad shape that it has to be taken up to the bench and taken down to effect proper repairs. The condition is due in many cases to the ignorance or carelessness of the operator, and when the cause of the trouble is ascertained, some advice to the operator would not be amiss. The causes of leaking may be divided roughly into—

1—Freezing.

2—Shaking apart through rough driving or the use of solid tires.

3—Radiator support breaking from same causes as No. 2.

4—Chafing caused by worn hood leathers.

5—Puncture caused by accident.

Regardless of the cause of the leak or the kind of leak, the repairshop should be equipped to fix it. There are

two separate and distinct operations to be gone through in overhauling the radiator: testing and repairing.

A testing outfit should include:

1—A testing tank, which is a wooden trough large enough to immerse the whole radiator with sufficient room to allow the hands to get around the edges. Sometimes this trough is built out of wood alone, the joints being made very close and caulked with cotton, the same as the seams in a boat. The usual way, however, is to have it lined with a sheet of galvanized iron or other metal, the joints being soldered. This absolutely prevents any leaking as long as a hole is not punched in the sheet metal, and in this case the wood only acts as a support. It is very convenient to have a drain board on one side of the tank so that after the radiator is tested in the water, it can be laid on the board to

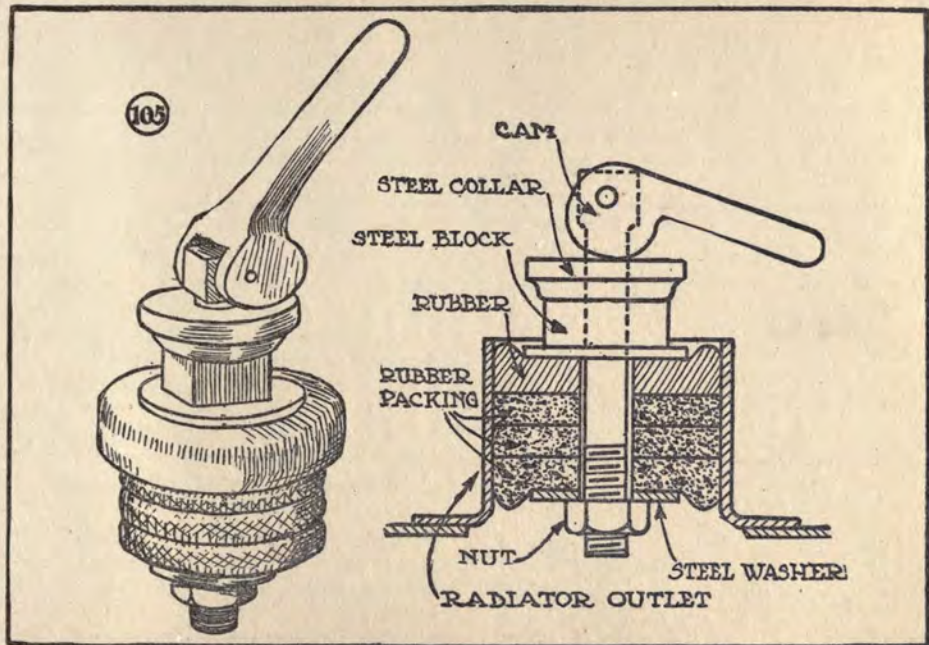
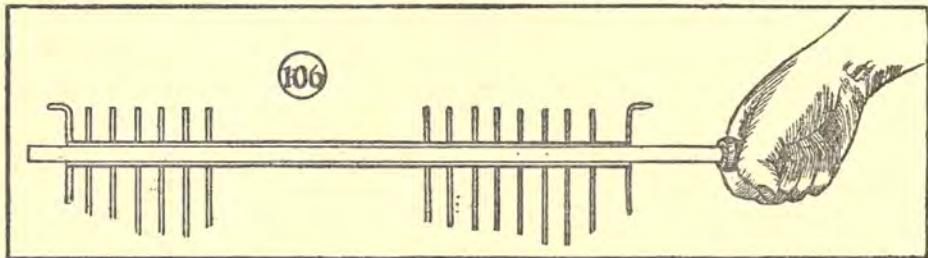


Fig. 105—Rubber compression plug used for making tight joints at inlet

drain and the water will drain back into the tank. This makes for a dry shop as there is no necessity for splashing water all over the floor.

2—A set of plugs to stop up the inlet and outlet water connections and the

may be, there being one plug for each of these openings. In operation, the plug is shoved in as far as it will go and the cam is then tightened. Tightening the cam compresses the rubber and expands it outward, forming a water



*Fig. 106—A bent tube is straightened by running a rod through it*

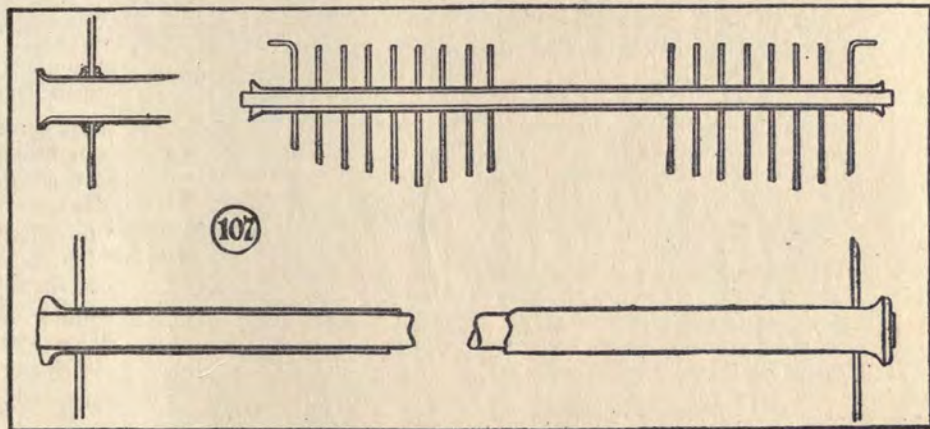
filler neck. Some of these are shown in Fig. 105. Each one consists of three rubber packing disks and a soft rubber disk, all mounted on a bolt and capable of being compressed by a steel block and a cam. The disks are cut to fit the inlet, outlet or filler neck as the case

and air-tight opening. When it is desired to remove the plug, the cam is simply pulled up and the plug comes right out.

3—Air pressure from a tank or a shop pump is necessary. The pressure is applied to the overflow pipe after the

other openings are closed up, then the radiator is immersed in the water contained in the testing tank. The air

for the repairman. After the repairing is all finished, the radiator should be tested again to check the work and



*Fig. 107—These sketches show the stages in inserting a tube*

pressure will force its way through any leaks that may be in any part of the radiator and these can then be marked

insure the stoppage of all leaks. The pressure used for testing radiators should not exceed a maximum of 15 lb.,

and 10 lb. will be found sufficient to locate any leak. More than 15 lb. is likely to put a serious strain on the headers. In case this low pressure is not available, the line pressure in the shop should be reduced by some kind of a regulator.

4—It is convenient to have full line pressure of from 100 to 150 lb. available for blowing the water and dirt from around places in the radiator that are to be soldered. This should be brought from one of the stop cocks through a rubber or flexible metallic hose to a short piece of pipe drawn out to a sort of jet about  $3/16$  in. diameter. After the radiator has been tested, this jet of air will quickly drive off the water and dry the spot up so that it can be soldered.

The results of the test and a careful examination will indicate the kind of a repair to make on the radiator. A slight leak in one, two or three tubes can be repaired by inserting special thin repair tubes in the original tubes, soldering

these in place. This will stop the leaks, but the additional thickness of the metal at these points will result in a reduction of the cooling efficiency of the radiator, and this kind of repair should not be used when more than three tubes leak.

When the support which extends across the lower part of the radiator is broken loose at the sides through jarring, the outside bands of the radiator are usually cracked or broken also, and if no serious damage had been done to the tubes the support can be anchored again and new side panels put in the radiator. In many cases, however, the breaking away of the support also chafes or tears some of the tubes and a more extensive repair job is necessary.

In any one of these repairs, the radiator will have to be torn down by unsoldering the sides and opening the top and bottom headers. New tubes or repair tubes can then be inserted without any trouble.

The following is a list of equipment that is necessary in radiator work:

Oxy-acetylene welding outfit with smallest tip.

Solder.

Soldering compound.

Scrapers.

Light hammer.

Punch.

Knife.

Pliers.

Rod for straightening tubes.

Emery paper.

1—The welding outfit with small tip is used both for soldering and for breaking joints. Properly used, it can melt the solder just at the desired points without allowing other joints to come apart. A large flame is absolutely useless, as the flame and consequently the heat cannot be confined to a small compass, and when you solder up one place two or three other places come unsoldered.

The soldering compound used depends largely upon personal likes and dislikes. The most common material is muriatic or hydrochloric acid which has had zinc



*Fig. 108—This is a handy stand for soldering and working on a radiator*

dissolved in it until it will not act on any additional metal which is put into it. This is called "killed" acid because it still retains its power of cleaning the metal, but has lost its strength so that it will not bite very deep into the metal. The purpose of a soldering compound is to clean the dirt and oxide off the metal so that the solder can get hold. Acid, although commonly used, is not the best material in the world to use because some of its power is still available, and if the joint is not perfect a small enclosed bubble of acid may in time eat through the joint. Various compounds of rosin and sal ammoniac are just as effective on brass and copper, the usual components of radiators, and there is no after-effect. However, the metal should be scraped or cleaned up with emery paper first, whereas the acid does not need this preparation unless the dirt is caked on too thick.

#### Inserting Repair Tubes

To permit of the insertion of repair tubes, the radiator tubes must first be

straightened. This is done by running a length of rod through each tube, the rod being fitted with a file handle and having a rounded end so that it will push out the bent places without cutting the metal away. (See Fig. 106, page 164.)

1—Make both ends of the leaky tubes bell mouthed and scrape the insides clean with a knife as far as can be reached.

2—Slide the repair tube into the other tube and cut the end off so that it extends about 1/16 in. at each end.

3—Apply soldering compound to the tube ends.

4—Using the small tip of the gas jet, heat the tip of the thin inner tube and run the solder into the bell shaped opening that has been formed.

Where the radiator is very badly damaged, it may be wise to insert a whole new core and if the headers and sides are also in bad shape, a new radiator would give more satisfaction



and be little more expensive than repairing the old one.

In replacing the radiator make sure that the springs are in place on the lower parts of the radiator studs and that the nuts are not set down too hard so that the spring action is destroyed.

This is the most frequent cause of radiator trouble. The springs are placed there to take the strain from the radiator and if they are omitted or their action is reduced or made inoperative, the radiator will not last long and will soon need rebuilding again.

## CHAPTER XXI

### Engine Numbers

**E**VERY Ford engine when it leaves the factory has a number stamped immediately above the inlet water connection at the side of the cylinder block. This number is not only useful in identifying the model and date the car was turned out of the factory, but it is also necessary in most states for the owner to supply the number to the automobile registration authorities in order to secure a license.

When replacing a cylinder block in an engine, therefore, the old number that appeared on the block should be stamped on the new block. For this purpose a set of numbering stamps is necessary. In some states it is even a criminal offence to be in possession of a car with an altered number or a car without any number at all. It is, therefore, important to attend to this detail.

The engine number is one that is used for reference on the Ford. There is

another number on the name plate on the dash, but this does not correspond to the number on the engine. It is to be particularly noted that the yearly models of the Ford begin in August of each year with the exception of the earlier years when this was a little different. The models previous to the Model T are practically extinct at the present time, but can be recognized by the fact that the circulating water pump is in front of the radiator.

The following list gives the engine numbers of all the machines turned out by the Ford Motor Co., with the month and year that each was turned out of the factory. This list may be used for identifying the parts which may have been changed from time to time, and will also serve as an indication of the age of the car for purposes of buying and selling. When the number of the engine does not agree with the age stated by

the owner, there may have been something entering into the matter that does not appear on the surface, such as the

substitution of another engine. In such cases inquiry of the factory or nearest branch will clear up the difficulty.

### Engine Numbers by Yearly Models

1911 Model (Oct. 1911-Dec. 1911).....	80,000 to	88,900
1912 Model (Jan. 1912-Sept. 1912).....	88,900 to	147,300
1913 Model (Oct. 1912-July 1913).....	147,400 to	299,200
1914 Model (Aug. 1913-July 1914).....	299,200 to	517,800
1915 Model (Aug. 1914-July 1915).....	517,800 to	855,500
1916 Model (Aug. 1915-July 1916).....	855,500 to	1,362,213
1917 Model (Aug. 1916-July 1917).....	1,362,213 to	2,113,500
1918 Model (Aug. 1917-July 1918).....	2,113,500 to	2,756,251
1919 Model (Aug. 1918-July 1919).....	2,756,251 to	3,277,851
1920 Model (Aug. 1919-June 1920).....	3,277,851 to	4,055,280

### Engine Numbers by Months

1908		1909—Continued	
Engine Number	Month	Engine Number	Month
I-II .....	October	2,025-2,691 .....	April
II-101 .....	November	2,691-4,036 .....	May
101-309 .....	December	4,036-5,980 .....	June
	1909	5,980-8,107 .....	July
309-646 .....	January	8,107-9,840 .....	August
646-1,052 .....	February	9,840-11,148 .....	September

1909—Continued		1911—Continued	
Engine Number	Month	Engine Number	Month
12,405-13,132 .....	November	66,700-70,500 .....	September
13,132-14,161 .....	December	70,500-83,100 .....	October
		83,100-86,300 .....	November
		86,300-88,900 .....	December
			1912
14,161-15,500 .....	January	88,900-92,000 .....	January
15,500-16,600 .....	February	92,000-95,900 .....	February
16,600-19,700 .....	March	95,900-103,800 .....	March
19,700-23,100 .....	April	103,800-112,900 .....	April
23,100-26,500 .....	May	112,900-123,800 .....	May
26,500-29,500 .....	June	123,800-132,000 .....	June
29,500-30,200 .....	July	132,000-139,700 .....	July
30,200-31,000 .....	August	139,700-144,500 .....	August
31,000-31,900 .....	September	144,500-147,300 .....	September
31,900-32,500 .....	October	147,300-156,300 .....	October
32,500-33,700 .....	November	156,300-161,200 .....	November
33,700-34,900 .....	December	161,200-171,300 .....	December
			1913
34,900-37,000 .....	January	171,300-186,900 .....	January
37,000-40,000 .....	February	186,900-203,300 .....	February
40,000-45,000 .....	March	203,300-218,900 .....	March
45,000-50,800 .....	April	218,900-242,300 .....	April
50,800-57,200 .....	May	242,300-260,000 .....	May
57,200-60,500 .....	June	260,000-282,700 .....	June
60,500-62,100 .....	July		
62,100-66,700 .....	August		

1913—Continued		1915—Continued	
Engine Number	Month	Engine Number	Month
282,700-298,200	July	723,500-805,500	May
298,200-306,800	August	805,500-839,700	June
306-800-314,800	September	839,700-855,500	July
314,800-324,900	October	855,500-881,000	August
324,900-344,900	November	881,000-913,000	September
344,900-370,400	December	913,000-949,000	October
		949,000-985,400	November
		985,400-1,029,200	December
1914		1916	
370,400-395,500	January	1,029,200-1,071,800	January
395,500-419,500	February	1,071,800-1,119,000	February
419,500-447,600	March	1,119,000-1,167,900	March
447,600-473,200	April	1,167,900-1,219,400	April
473,200-490,920	May	1,219,400-1,272,000	May
490,920-507,102	June	1,272,000-1,326,900	June
507,102-517,800	July	1,326,900-1,362,213	July
517,800-538,200	August	1,362,213-1,400,900	August
538,200-558,300	September	1,400,900-1,452,200	September
558,300-583,400	October	1,452,200-1,510,500	October
583,400-599,100	November	1,510,500-1,570,700	November
599,100-611,100	December	1,570,700-1,614,600	December
1915		1917	
611,100-614,200	January	1,614,600-1,680,000	January
614,200-630,500	February	1,680,000-1,739,900	February
630,500-682,400	March		
682,400-723,500	April		

1917—Continued		1919	
Engine Number	Month	Engine Number	Month
1,739,900-1,812,000	March		
1,812,000-1,888,000	April	2,831,400-2,880,170	January
1,888,000-1,968,629	May	2,880,170-2,933,000	February
1,968,629-2,044,100	June	2,933,000-2,997,100	March
2,044,100-2,113,500	July	2,997,100-3,067,700	April
2,113,500-2,162,800	August	3,067,700-3,140,000	May
2,162,800-2,231,000	September	3,140,000-3,210,800	June
2,231,000-2,310,400	October	3,210,800-3,277,851	July
2,310,400-2,383,900	November	3,277,851-3,346,900	August
2,383,900-2,449,100	December	3,346,900-3,429,400	September
	1918	3,429,400-3,515,400	October
2,449,100-2,503,200	January	3,515,400-3,588,000	November
2,503,200-2,558,200	February	3,588,000-3,659,970	December
2,558,200-2,611,400	March		
2,611,400-2,657,500	April		
2,657,500-2,700,800	May		1920
2,700,800-2,735,700	June	3,659,970-3,743,075	January
2,735,700-2,756,250	July	3,743,075-3,817,430	February
2,756,250-2,774,600	August	3,817,430-3,910,000	March
2,774,600-2,787,800	September	3,910,000-3,969,150	April
2,787,800-2,792,300	October	3,969,150-4,055,280	May
2,792,300-2,805,100	November		
2,805,100-2,831,400	December		

## CHAPTER XXII

### The Front Axle Assembly

**O**VERHAUL operations of the front assembly may be divided roughly into two classes which require somewhat different treatment. In the first place, where the wheels only are to be worked on, a quick-acting jack which will raise the front wheels clear of the ground is all that is necessary.

In the second place, complete overhaul of the front assembly or any operation which entails the removal of the axle itself or the removal of the spring will necessitate lifting the frame of the car and thus leave the axle hanging.

Such a device is shown in Figs. 109 and 110.

1—There are two hooks at the lower end of the device and a ring at the top. Hook the hook of a chain hoist into the ring and adjust the height so that the hooks are a little below the level of the lamps.

2—Hook each of the hooks on the fender iron below the nut on the end of the lamp bracket.

3—Raise on the chain hoist until the wheels are just clear of the floor.

4—Remove the cotter pins and take the nuts off the studs which hold the ball cap of the radius rod.

5—With a speed wrench, remove the nuts and bolts from the cap on the ball socket on the lower end of the steering arm.

6—Remove the cotter pins, nuts and bolts from the spring shackles.

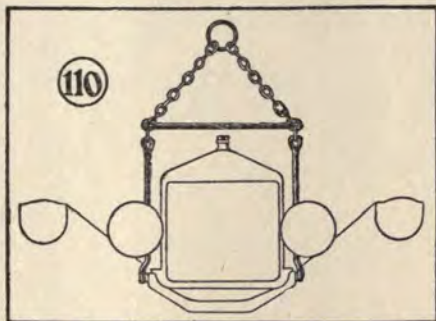
7—This will allow the axle to drop down till the wheels rest on the floor and the connections will be loose so that the axle can be wheeled out to the bench.

8—If the hoisting hook is needed elsewhere, the car can be dropped down on a couple of short jacks placed under





11—Remove the hub caps with the hub cap wrench. The quickest way to do this is to start the cap off by holding



*Fig. 110—Front end hook in position. Each hook is placed on the fender iron below the nut on the end of the lamp bracket. The large ring at the top is put on the hook of a chain fall*

the tire of the wheel with one hand and striking a few blows with a hammer on the wrench when it is in position on the

hub cap. As soon as the cap is loosened, hold the wrench with one hand and spin the wheel with the other.

12—Remove the surplus of grease.

13—Take out the cotter pin.

14—Loosen the nut with the hub cap wrench which has a smaller hexagon hole in the other end for this purpose. The nut is usually on so tight that the wrench must be struck with a hammer to start it.

15—Take off the lock washer which slips off by hand.

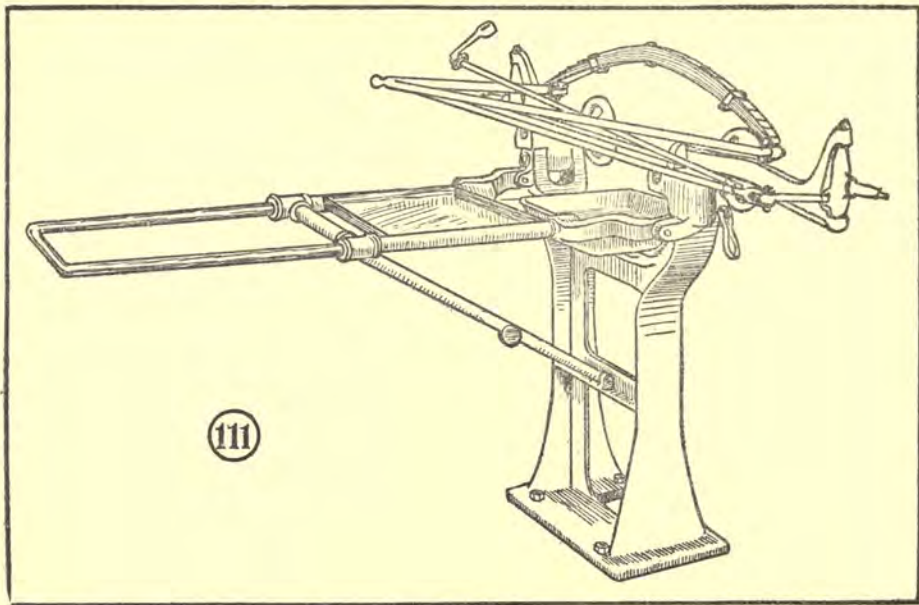
16—Unscrew the outer cone. This sometimes will come off by hand, but if it will not, there are two recesses, one on each side and any adjustable wrench can be used to unscrew them.

17—The wheel will now lift off.

18—Repeat the operations with the other wheel.

19—Wash off all the parts, removing all grease and particles of ground metal.

20—Examine the balls in both the inner and outer races, checking them



*Fig. 111—A combination stand which is used for holding the front axle.  
The two jaws hold it firmly while the operations are performed*

up to see whether any are missing and then roll them around with the fingers to see if any of the balls have flat sides or are broken. A broken or damaged ball must be replaced and if several are damaged or missing, it is best to replace

not give readily. They should be elastic enough to hug closely so as to keep the grease in and the dust out.

22—Examine the wheels themselves. If the spokes are loose or shaky or if the wheels have been strained so that



*Fig. 112—Spindle bushing reamer which reams the two bushings so that they are in perfect alignment*

the entire set. It is really best to replace the entire set anyway as the new balls will all be of one size, whereas replacing one or several puts new balls of standard size in the same race with balls that may be worn below size. This will throw all the strain onto the new balls and may cause them to break or to score the races.

21—The felt dust washers should be replaced if they are so stiff that they do

they are out of alignment, new wheels should be installed.

23—To remove the hubs from the wheels, hold a blacksmith's chisel on each of the flange nuts in turn and hit it a sharp blow with a hammer. This will break off the bolt, as the bolt is pretty hard. The old bolts can then be driven out with a punch, the parts of the hub separated and a new wheel put in.

24—The bearing races are removed on the arbor press with the drivers shown in Fig. 115 on page 182.

### Assembly of Wheels

1—Replace races which are worn or cracked. The wheel parts of the races are inserted on the arbor press with the same drivers that they were removed with.

2—New balls are inserted by laying the wheel flat, filling the race with grease and sticking the balls into the grease. The adhesion of the grease will keep the balls from falling out. After the retaining rings are slipped into place the balls cannot fall out.

3—The inner race of the large bearing can be removed by cracking it off with a hammer or driving it with a cold chisel. The new one is replaced on the spindle by driving it on with a short piece of pipe and a hammer.

4—In adjusting the wheel bearings, set the adjusting cone up with the wheel spinning. When the cone gets tight enough to brake the wheel, loosen

it about one-third turn, put on the lock washer, replace the nut and tighten it up as hard as it will go.

5—Test the wheel again. It should be loose enough to allow the wheel to spin freely and finally rock back and

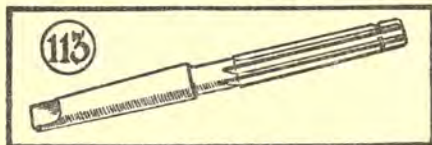


Fig. 113—Spindle arm and spring perch bushing reamer

forth with the valve at the bottom. If it stops abruptly at any point, the bearing is too tight.

6—It should not be so loose that there is a perceptible shake to the wheel.

### Spindle Body Bolt and Bushings

1—Before the spindle bolts are removed the nuts and bolts connecting the steering arms to the tie rod should be

disconnected so that when the spindles come out, the spindle bodies can be lifted right out either with or without the wheels, as the case may be.

2—Remove the cotter pin and the nut underneath the axle.

3—If the spindle has been oiled pretty regularly, there should be little trouble in turning the bolt out. If, however, the spindle has never been given any lubrication, as is often the case, heroic methods may be necessary to get the bolt out. The following methods have been used to advantage:

4—Pour kerosene through the oil filler and around the crack between the spindle body and the bushings, allowing it to remain there some time. This may cut the rust sufficiently to allow the bolt to be turned out.

5—If it does not respond to the kerosene treatment, heat the lower lug on the axle with a blow torch. It should not be heated much more than the boiling point of water because the axle is heat treated, and if the heat applied is too great, it will soften the axle, result-

ing in possible bending of the part, which may result in a serious accident.

6—If neither of these methods proves successful, saw the bolt off with a hack saw just under the top lug of the axle. Then with a large wrench bend the spindle body out until the spindle body can be pulled off the bolt. Then bend the bolt back in position and turn it out with a pipe wrench.

7—If it refuses to respond to the pipe wrench, saw the bolt off flush and drill the old stump out, retapping the hole. If the threads are gone, the hole is bored larger, a plug inserted and then the plug is drilled and tapped.

8—There are hundreds of ways of taking out the spindle body bushings. Two of these methods are shown in Fig 116 and another tool for the same purpose is shown in Fig. 115 at A. These are self-explanatory.

9—When the new bushings are inserted they are to be reamed with the reamer shown in Fig. 112. This is in the form of a lining reamer so that the two holes will be absolutely in line.

Where the lining reamer is not available, the bushings should be taken out one at a time and reamed through the old bushing, using this as a guide.

10—The bottom bushing should be filed with a flat mill file till the spindle body with its bushings will just go in the space between the lugs on the axle. Lost motion is to be avoided at this point, so that the filing will have to be done carefully. As a rule, not very much filing is necessary.

11—In replacing the spindle bolt, see that the oil passage is clear so that the bushings will be properly lubricated when oil is put in the filler.

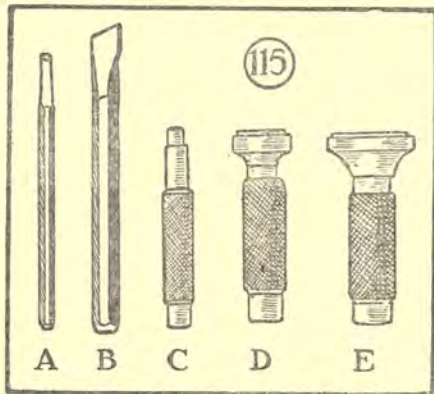
### Spring Repairs

All of the rattle can be taken out of the springs by rebushing the eyes and inserting new bolts. The bushings are driven out on an arbor press and new ones inserted in the same way.

1—Use the proper driver on the arbor press.

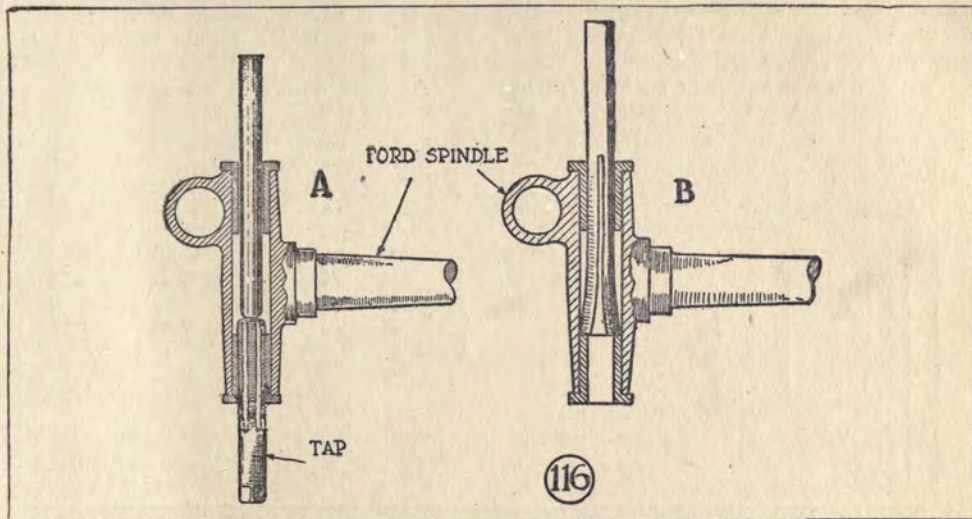
2—After replacing the bushing, ream it with the reamer shown in Fig. 113.

3—Put in new bolts, set up the nuts and insert cotter pins.



*Fig. 115—A is a spindle body bushing bracket, B an inner or outer ball race remover, C a spindle arm bushing driver, D a front wheel outer ball race driver, E a front wheel inner ball race driver*

4—In replacing a broken leaf, the spring must be taken apart, the broken



*Fig. 116—Two methods of removing spindle body bushings. A shows a tap started in one of the bushings so that an old spindle bolt can be driven against the bottom of the tap, both tap and bushing being driven out. B is a split pin which is compressed to get it in the top bushing, the legs then spreading out so that they will push the other bushing out*

pieces removed and a new leaf inserted.

5—The leaves should be laid up in a mixture of grease and graphite.

6—The center bolt can be inserted by

### Straightening the Axle

1—A bent front axle is straightened cold by using the bending bar shown in Fig. 114. This has sufficient leverage to

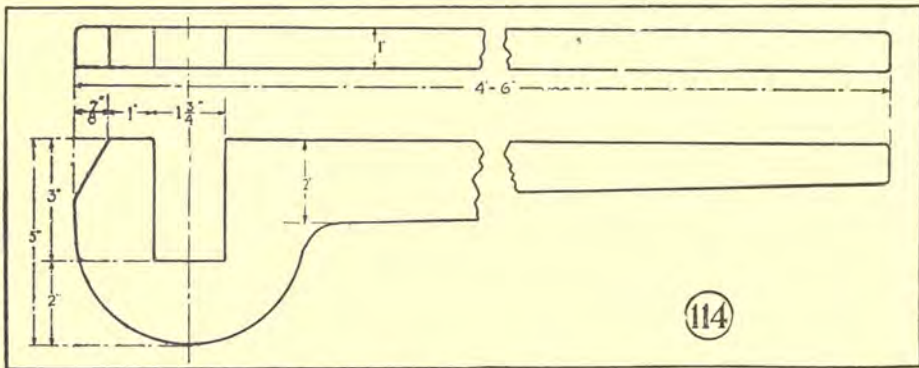


Fig. 114—Front axle bending iron

gripping the leaves in a vise and tightening the jaws up until the nut can be put on the center bolt.

bend any part of the axle.

2—A template is convenient for use when using the bending bar and one can



be cut out of a piece of wood or sheet metal, using a new axle as a guide. It should be so cut that it touches the upper part of the I-beam of the axle all the way across. By bending the old axle to correspond to this template, one can be sure that the axle is straight. Another template can be made to fit across the top of the axle to check up the alignment in this direction.

3—Place two steel bars which are the same diameter as the spindle bolt and threaded on the lower ends in the spindle bolt holes. By looking across these the alignment of the spindles can be checked up and corrected if necessary.

4—A bent radius rod had best be replaced with a new one, as the slightest buckle will weaken it and make another bend imminent at any time. The old rod is removed by taking off the two nuts in front and driving out the stubs.

5—New bushings are put in the steering connections by driving out the old ones, inserting new ones and reaming

them out to the correct size. New bolts should always be used.

6—In lining up the front wheels, the bolt is slipped out of one end of the tie rod yoke and the yoke turned one way or the other till the distance between the fronts of the rims is about  $\frac{1}{4}$  in. less than the distance between the rear of the rims. The distance between the tops is considerably greater than between the bottoms so that the center of the tire comes approximately beneath the spindle bolt.

7—Before turning the front assembly out as being properly adjusted, check up the following points:

8—Grease in the hub caps.

9—Connections all tight with no rattles.

10—All bolts and nuts tight.

11—All cotter pins in place.

12—Spring clips set up tight and cotter pins in place.

13—Grease in spring leaves.

14—Wheel bearings correctly adjusted.

15—Axle and wheels in line.

## CHAPTER XXIII

### The Rear Axle Assembly

**T**HE first step in the economical overhaul of the rear assembly is to have the necessary tools at hand and in such places that the mechanic knows instinctively where each tool is and where to lay his hands on it with his eyes shut if necessary. This can be accomplished by having a series of pegs or nails on a large board where it is within reach of the axle stand. The tools can be arranged logically on the board so that the mechanic can soon learn where they belong. Then the next step is to insure that these tools shall always be where they belong.

There are essentially three parts to the job—

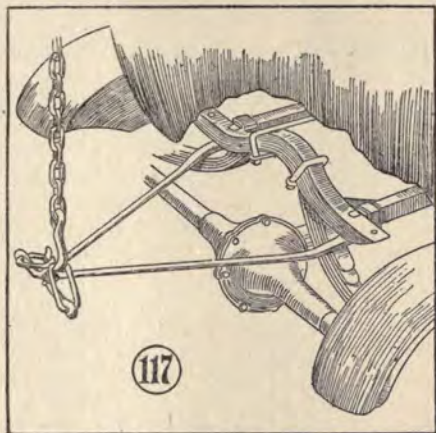
1—Disconnecting the axle from the chassis and taking it out from under the car.

2—Disassembling, replacing parts and assembling.

3—Replacing the axle in the car.

The quickest way to get the axle out is to have a rear end hook which is shown in Figs. 117 and 118. This is attached by placing the clamps on each end of the bar on the frame and then bringing the ends of the bars together, one bar resting in the safety clevis on the other bar. The links are then placed in the hook on the chain fall. This hook will lift the chassis and body up independently of the axle.

A combined rear axle jack and truck is placed under the axle so that when the connections are broken, the axle can be wheeled right out from under the car. This jack which is shown in Fig. 124, is triangular in form, the base being constructed of 2½-in. angle iron. The pieces are bolted together and mounted on swivel castors. The two strap iron supports carry the axle and the steel handle is used as a lever to force the supports under the axle to raise it from the floor



*Fig. 117—Rear end hook in position for raising the rear end of the Ford. In attaching the hook, place the clamps on the end of each bar on the frame, then bring the ends of the bars together, one bar resting in the safety clevis on the other bar. The links are then placed in the hook on the chain fall*

and also as a handle to pull the whole outfit around with.

1—Put the rear end hook in position and raise on the chain fall until the wheels are clear of the floor.

2—Slip the axle jack under the axle so that it takes the weight off the springs.

3—Block the front wheels in front and in back.

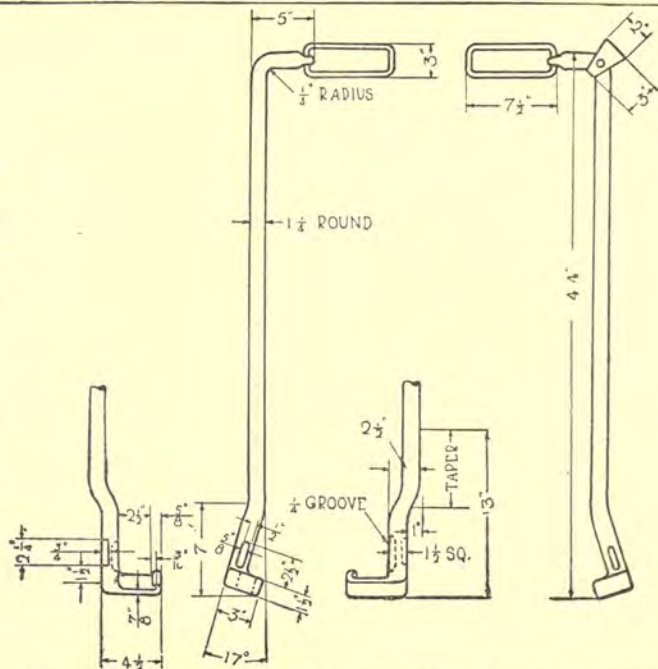
4—Remove the hub caps with the hub cap wrench. These will most likely have to be started with a hammer, then when loosened, the wheel is turned while the wrench is held still.

5—Remove the cotter pins from the axle ends.

6—Remove the nuts, starting them with an L-wrench if necessary, then finishing the job with a speed wrench.

7—Grasp one of the rear wheels by the tire and pull outward. If the wheel does not come off easily, hit the axle end with a medium weight hammer, interposing a piece of wood to protect the threads and the wheel should pop right off.

*Fig. 118 — Detail plan of the rear end hook. This can be made by any blacksmith. The hooks are put inside the frame and hooked around the side members, the chain hoist being hooked into the links*





front by taking out the cotter pins and pulling out the clevis pins.

12—Remove the cotter pins from the universal joint flange bolts.

13—Remove the flange nuts and bolts, using a 6-ft. speed wrench with a  $\frac{3}{8}$ -in. socket. The use of this long wrench enables the mechanic to remove these bolts without getting under the car or working in the cramped space under the floor boards.

14—This frees the axle entirely from the car and it can be pulled out on the truck jack and brought to the rear axle stand.

15—Two kinds of axle stands are shown in Figs. 119 and 123. The entire axle is placed on one or the other of these.

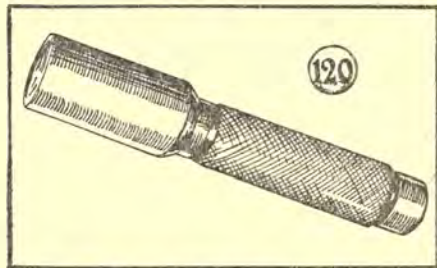
#### Disassembling the Axle

16—Remove the cotter pins and nuts from the ends of the radius rods, using a speed wrench.

17—Using a  $\frac{7}{16}$ -in. socket speed wrench with a  $4\frac{1}{2}$ -ft. handle, remove the torque-tube retaining nuts.

18—The drive-shaft housing or torque tube can now be pulled right out, bringing the drive shaft, pinion, etc., with it.

19—A Jew speeder shown in Fig. 126 is used for removing the bolts and nuts



*Fig. 120—Tool for driving roller bearing sleeve on propeller shaft*

that hold the halves of the axle housing together.

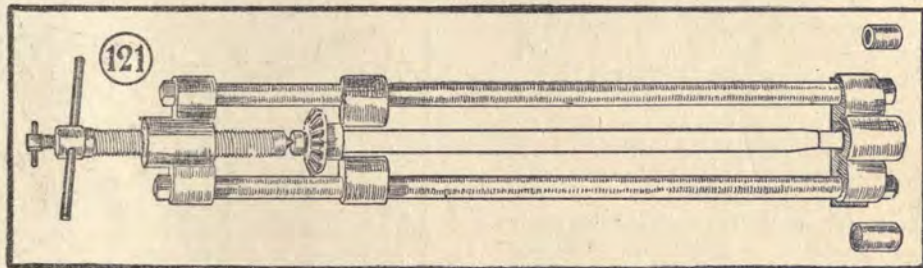
20—Pull the halves of the housing apart, having previously placed a bucket underneath to catch the "soup" or soft grease.

21—The keys are removed from the shafts, the right one before the housing is slipped off and the left one after the right half is taken off. This will permit the complete disassembly of the axle, the differential casings being separated

this is too tight a fit, it may have to be taken down a little with a fine mill file and this must be carefully done.

#### Disassembling the Drive Shaft

1—Remove both top and bottom pipe



*Fig. 121—Rear axle pinion gear press*

by removing the three bolts. The thrust washers will now drop out.

22—The overhauling is completed by replacing parts which have to be renewed. There is no fitting required on any of the parts with the possible exception of the babbitt thrust washer. If

plugs from the forward end of the drive shaft housing.

2—Turn the shaft around until the universal joint pin comes into view.

3—Drive out the pin with a punch.

4—Drive the universal joint away from the housing.

5—Remove the cotter pin from the nut that holds the pinion gear on the shaft.

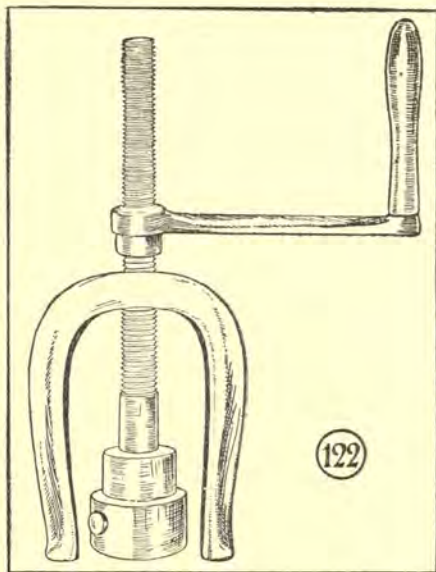
6—Remove the nut with a heavy  $\frac{7}{8}$ -in. socket wrench.

7—Place the shaft in the press shown in Fig. 121 and placing the stud at the end of the shaft and the pipe over the shaft, apply pressure. This will force the pinion gear off. Do not lose the key unless you are going to replace it.

8—To replace the gear on the shaft, place the short pipe under the gear and apply pressure directly to the end of the shaft, having first inserted the key. This will push the gear on.

9—Before replacing the shafts, center them in a lathe or in the testing centers which were described in the section devoted to crankshaft work. If the shafts are bent, straighten them in the same press that was used for crankshaft and camshaft work or else replace them with new ones.

10—Before assembling, all parts are to be washed off and examined for wear



*Fig. 122—Rear axle sleeve puller*



and breakage and replacements made accordingly.

11—The differential should turn freely by hand and the gears should mesh throughout their tooth length. Everything must be set up tight and new cotter pins used in every case.

#### Assembly of the Units

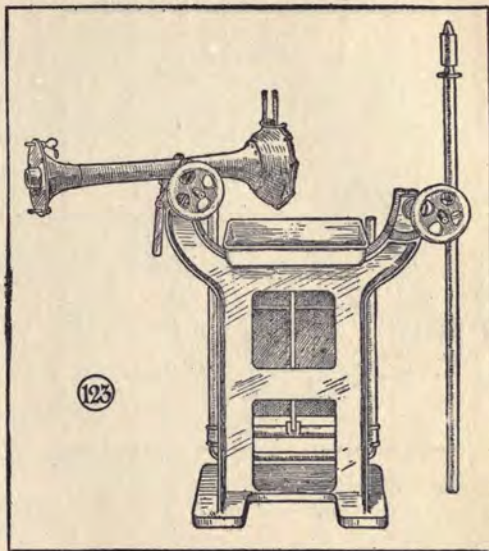
1—Fill the bearings with grease in every case as the parts go together.

2—The assembly is just the reverse of the disassembly.

3—Pack the universal joint in grease and fill the differential with grease. This insures lubricant getting right where it is supposed to go as soon as the car starts off. After the assembly of the axle is complete, more grease can be put into the housing with a gun.

4—Roll the axle under the car.

5—Use a bicycle wrench, thin solid wrench or spark plug wrench to turn the square end of the universal joint so that it will enter the square hole in the transmission.



*Fig. 123—All-metal combination stand which is used for rear axle*

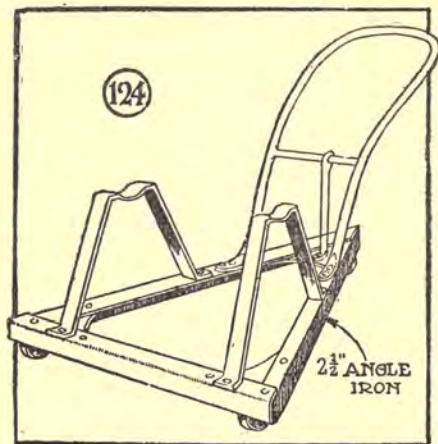


Fig. 124—Quick-acting rear axle jack and truck

6—Be careful not to damage the round gasket.

7—Insert the bolts in the flange, tight-

en them with the speed wrench and put on the nuts and cotter pins.

8—Connect up the springs to the axle.

9—Connect the brake rods, adjusting

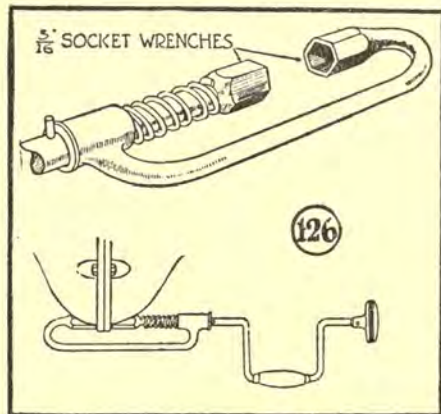


Fig. 126—Jew socket wrench for removing differential flange nuts

them so that the brakes take hold equally and do not bind. This is done by loosening the lock nut and turning the yoke in or out until the correct adjustment is obtained. If the brake shoes are worn so that a good adjustment cannot be ob-

sure that the keys are in place.

13—Insert the cotters.

14—Replace the hub caps.

15—Replace cups and fill with grease.

16—Be sure that the pipe plugs are in place in the top and bottom of the drive

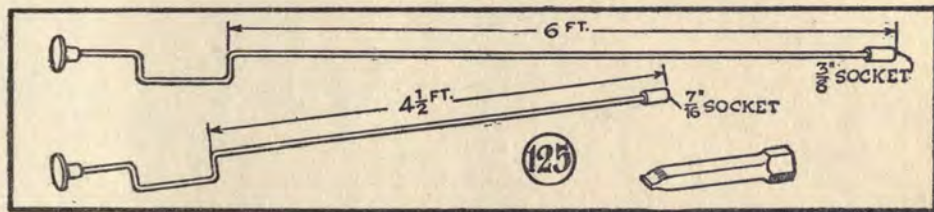


Fig. 125—Special speed wrenches for rear axle work

tained, they should be replaced with new ones.

10—Replacement of broken springs is taken care of in the same manner that was used for the front springs, this being described in the previous chapter.

11—Replace the wheels.

12—Set the nuts up tight, being first

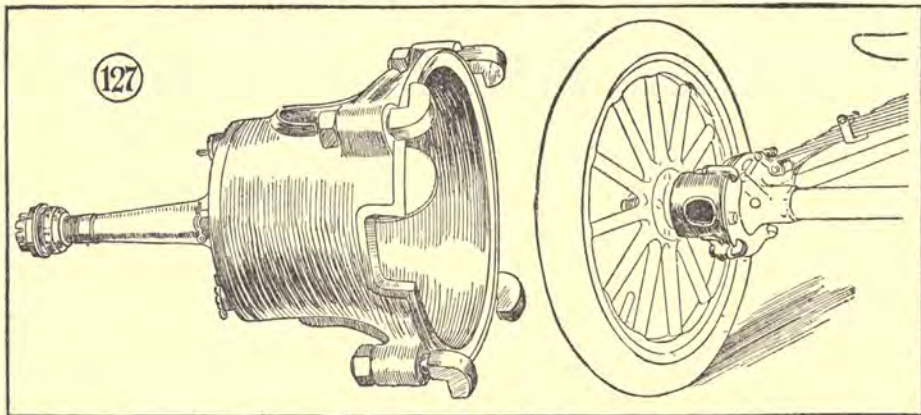
shaft housing.

The total time for overhauling an axle should not be over 1 hr. for one man if all things are in proper order and if the modern methods described here are used.

A device for towing in Fords with broken rear axles is shown in Fig. 127. While this is not strictly repairshop

equipment, yet every shop is called upon at times to tow in a car with a broken shaft and there are so many slouchy methods of doing this that the correct and best method seems worth mention-

ing. This device can be attached in a few minutes' time and there will be no worry about getting the disabled car into the shop in safety. Of course, the car cannot be driven in.



*Fig. 127—A device for towing a Ford with a broken axle. A front wheel is mounted on the spindle and the clamps tightened over the axle*

## CHAPTER XXIV

### Miscellaneous Parts

**T**HE Ford steering gear is probably unique in automobile design on account of the gear reduction taking place in the head of the steering column rather than through worms or quadrants at the base of the post. The usual overhaul job on a steering gear is for the purpose of either taking out lost motion or replacing broken or damaged parts.

The lost motion may be looked for in the following places—

1—Wear in the pinions, internal gear case or drive pinion. The gears need infrequent lubrication, in fact the Ford manual calls for packing with grease but once a year on the average, and yet, the large majority of steering gears do not get even that much, and the consequence is that the gears wear out.

2—Wear between the balls and caps, one on the bottom of the steering arm and one at the right side of the tie rod

looking forward.

3—Wear on steering knuckle pins and bushings.

4—Wear on spindle bolts and bushings. This would ordinarily be taken up in the front assembly overhaul.

To disassemble the steering gear—

1—Remove the acorn nut on top of the steering wheel.

2—Drive off the steering wheel spider as shown in Fig. 128.

3—Unscrew the lockscrew on the steering gear case. If it is not necessary to remove the spider from the shaft, omit operations Nos. 1 and 2.

4—Unscrew the cover of the gear case and lift it off. If the wheel spider has been removed, the cover will slide up over the shaft which is pulled out afterward. If the spider has not been removed, the spider, shaft and cover will all come off together.

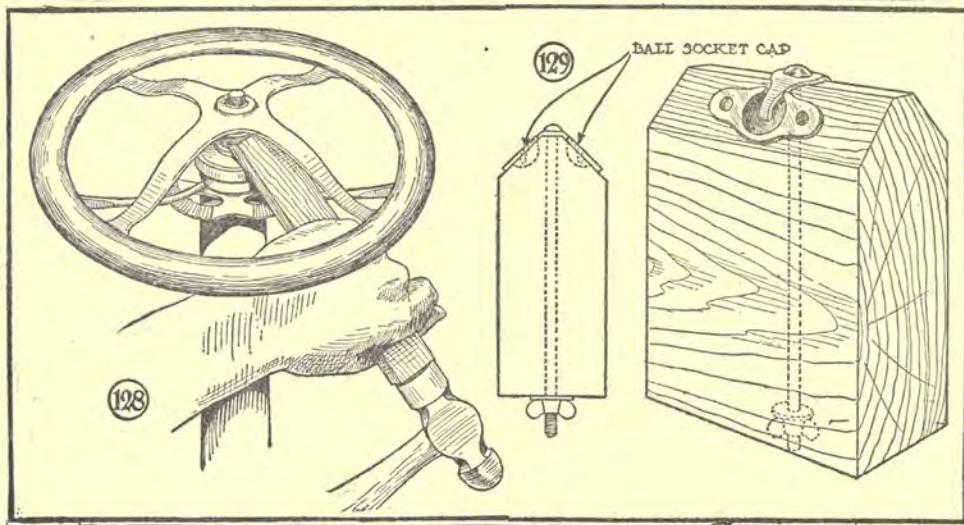


Fig. 128—The steering wheel is removed by taking off the nut and driving the spider off with a block of wood and a hammer

Fig. 129—This is a jig for grinding down ball caps to take up for wear. Two of them are clamped in the jig and the faces ground on an emery wheel

5—Lift out the pinion gears.

6—Remove the steering column nuts from the bolts that go through the dash, using a speeder.

7—Remove the cotter pins, bolts and nuts from the ball cap on the lower end of the steering arm.

8—Remove the timer and throttle rods.

9—Remove the bolt and nut from the lower support of the steering column. This will permit the steering gear to be withdrawn from the dash. For minor overhauls it will not be necessary to take the steering gear completely out and therefore some of these operations may be omitted.

10—Most likely the ball caps on the steering gear will need taking down to get rid of the lost motion at this point. Fig. 129 shows a device for performing this operation quickly and accurately. A block of wood is cut to the shape shown and a T is welded to the end of a long stud which goes through a hole in the block. By placing two of the caps in the recesses cut in the wood and then tightening the thumb screw down on the stud,

they will be held rigidly in position and the faces of the caps can be dressed down on the side of an emery wheel.

11—Dress the caps down so that there is no rock to the caps, but do not take so much off that the cap binds on the ball.

12—Pack the caps with grease before replacing.

13—Replace the necessary parts in the upper part of the steering gear and pack with grease before assembling the cover.

14—The arms on the throttle and timer shafts should be tight and if much worn should be replaced.

15—A new rim can be put on the spider by unscrewing the screws, removing the old rim and putting on a new one. See that the screws are good and tight.

16—The assembly of the gear is exactly the reverse of the disassembly.

17—Be sure to set all bolts up tight and put in cotter pins where required.

18—In the older model cars with wooden dash, set the steering column support nuts tight. Sometimes the wood splits away at the lower side of the dash

and if there is not sufficient damage done to warrant a new dash, the trouble can sometimes be remedied by placing a few washers under the nuts.

19—The steering wheel should have just the slightest amount of lost motion. If too tight, the ball caps have been ground down too much or some of the other parts are not set up right. If too loose, there is wear in the gears, the gear housing is loose from the steering column, or there is lost motion in the ball caps or at the spindles.

20—The adjustment of the front wheels was covered in the chapter on overhauling the front assembly.

### The Muffler

1—The Ford muffler is very easily and quickly disassembled if the body is off the chassis, but if the engine is in place and the body bolted on, it is most convenient to remove the bolts which hold the muffler bracket to the frame. This is done from underneath. A section of the muffler is shown in Fig. 130.

2—The muffler will now slide off the

exhaust pipe and can be taken right out.

3—If the muffler is badly rusted up or broken it is an economy to replace it with a new one.

4—If susceptible of repairs, the through bolts are taken out and the two headers will come apart allowing the inner shells to drop out. These are either cleaned or repaired as the case may be, and then replaced as they were.

5—See that the slots on the smaller shell are at the rear and the slots on the larger shell are at the front. Otherwise the muffler will not perform its function correctly.

6—Replace the headers, the shells fitting into the ledges on the headers.

7—A new asbestos sheet is wrapped around the outside and held on with the tin strips.

8—Replace the muffler and bolt to the frame.

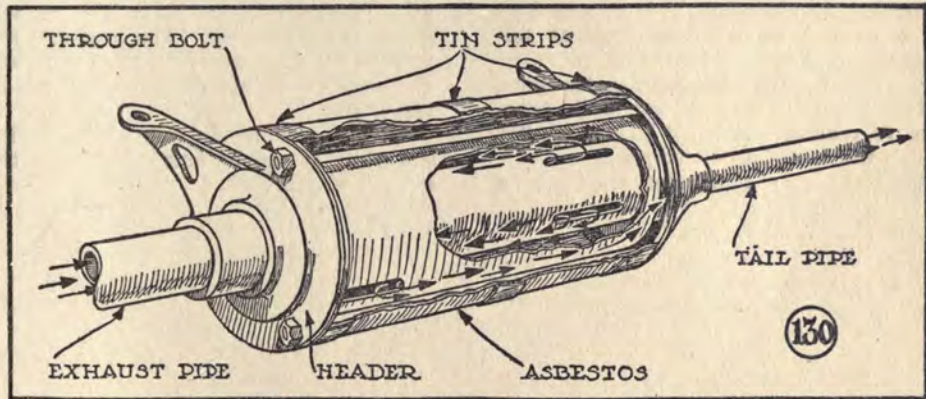
### The Gasoline Tank

1—The tank is supported on the frame with two supports, one of them being in the form of a cradle with two points of



support and the other with one point of support. The only thing liable to get wrong with the tank outside of a punc-

2—If the tank is punctured, it can be soldered up in the ordinary way, first removing all the gasoline and allowing



*Fig. 130—The muffer is easily disassembled by taking out the three long bolts which will allow all the parts to drop out. The headers have ledges to hold the shells in their proper position, and in re-assembling the slots must be put at the opposite ends of the muffer*

ture is the loosening of the bolts which attach it to the frame.

fresh air to blow in the filler hole to remove all the gasoline vapor so there will

be no chance of an explosion occurring.

3—A stopped up feed pipe is remedied by removing the coupling nuts at both ends, taking the pipe out of the car and removing the obstacle. This may be done in a number of different ways as follows:

4—Run a stiff wire through the pipe, afterwards washing it out with gasoline to remove the small pieces of dirt which the wire has dislodged.

5—Make up a connection with a feed

pipe coupling so that the feed pipe can be connected to the steam supply by means of the coupling. A stop cock will allow the steam to be turned on and off. If steam is not accessible, connect up to the air supply. The pressure will remove the obstruction in most cases and the heat of the steam will generally do the trick.

6—The strainer is cleaned by taking it apart. It can be unscrewed from the bottom of the tank.

## CHAPTER XXV

### Care and Repair of the F. A. Starting and Lighting System

THE F. A. starting and lighting system now being installed on Ford sedans and coupés is of the two-unit type and consists of:

- 1—Starting motor.
- 2—Generator.
- 3—Storage battery.
- 4—Charging indicator.
- 5—Lights.
- 6—Necessary wiring and connections.

The starting motor is mounted on the left side of the engine and is bolted to the transmission cover. When in operation the pinion of the Bendix drive shaft engages with the teeth of the engine flywheel.

#### Instructions for Starting the Engine

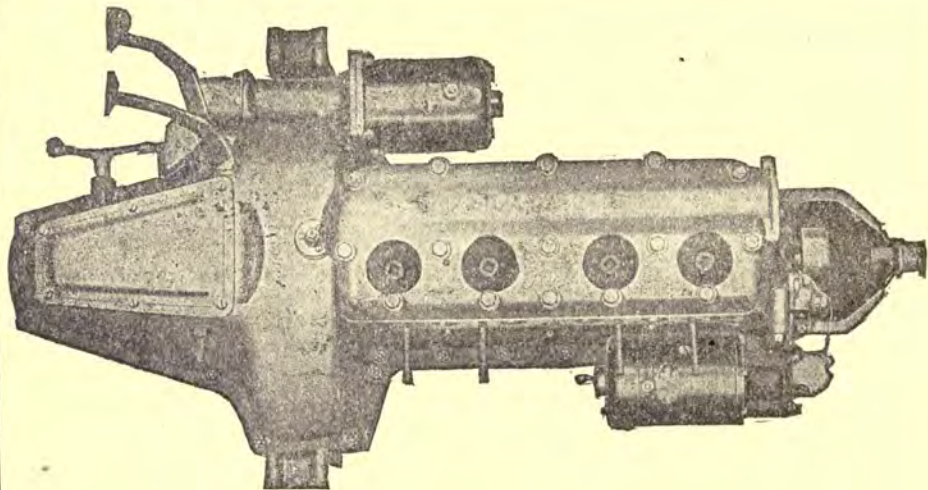
1—Place the spark and throttle levers in the same position on the quadrant as when starting by hand—the spark lever in the third or fourth notch and

the throttle lever in the fifth or sixth notch.

2—Turn on the ignition switch. The engine may be started either on battery or magneto, but the use of the magneto is strongly recommended, as just as hot a spark will be produced and the battery will have less drain put upon it. However, in very cold weather, when the starter will not turn the engine over very fast, owing to thickened oil, the battery will give quicker results in starting. As soon as the engine starts, switch to the magneto.

*The spark must not be advanced too far or the engine will backfire, and this may bend or break the shaft of the starter.*

3—Press down on the starter push button, which is located on the floor of



*Fig. 1—Top view of the Ford power plant, showing the generator mounted at the right front of the engine and the starting motor engaging the teeth of the flywheel through the transmission cover*

the car at the driver's feet. This button connects the circuit and makes the current flow from the battery through the starting motor, causing it to turn and causing the Bendix drive shaft to engage with the flywheel teeth, turning the engine over.

4—If the engine is cold, it is primed by pulling out the carbureter priming rod, which is located on the instrument board. This should be held out for only a few seconds at a time to prevent flooding the carbureter.

#### Causes of Failure to Start

1—If the starting motor turns the engine over and the engine refuses to start, the trouble is not in the starting system, but is in the engine or some of its accessories or equipment. In such a case release the button and look for trouble with ignition, carburetion, or other trouble with the engine. Continuing to press the button will only discharge the battery and will not remedy the trouble.

2—If the starting motor does not act

when the button is pushed, then the trouble is in the starting system, and faults may be looked for as follows:

3—See that the connection to the terminal of the starting motor is tight.

4—See that the connections to the two battery terminals are tight.

5—See that the connections to the two terminals on the starting switch are tight.

6—See whether any of the wires are broken or have the insulation damaged so that a short circuit exists between the wire and the frame of the car or some other metal part.

7—Examine the condition of the battery. It may be run down. Test it with a hydrometer. If it is less than 1.225 there will not be enough current to turn the engine over. There may not be enough electrolyte in the cells to cover the tops of the plates and this may be caused either by evaporation or by a leaky battery jar.

#### The Generator

1—The generator is mounted on the

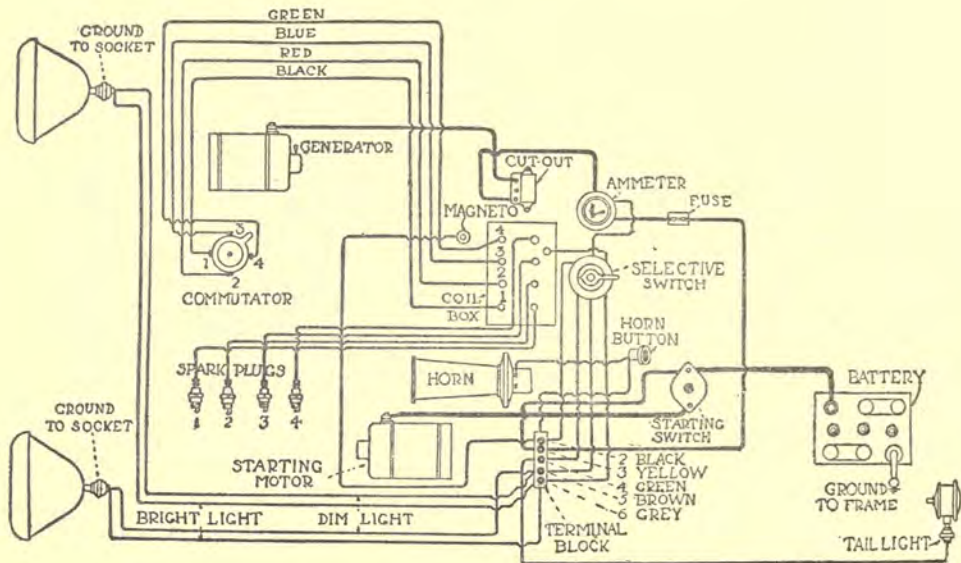


Fig. 2—Wiring diagram of the F. A. Starting and Lighting system as now installed on Ford Sedans and Coupes

right side of the engine and is bolted to the cylinder front end cover. The pinion of the armature shaft engages with the large timing gear, and the charging rate of the generator is set to cut in at engine speeds corresponding to car speeds of 10 m.p.h. It reaches its maximum rate at 20 m.p.h.

2—To remove the generator take out the three cap screws holding it to the front end cover.

3—Place the point of a screwdriver between the generator and the front end cover, prying it off. Start at the top and force it backward and downward at the same time.

4—If necessary to run the car without the generator, plates can be obtained from Ford branches to put over the timing gear.

5—If the engine is to be run with the generator disconnected from the battery, be sure that the generator is grounded to the engine frame by running a wire from the terminal of the generator to one of the valve-cover stud nuts. A piece of wire at least 1/16 in. in diameter should

be used and both connections must be made tight. Failure to ground the generator when the engine is running with the generator disconnected will seriously injure the generator.

6—Ford dealers are instructed by the factory not to take the generator or starter apart, but to return the units to the Ford branch for repair or replacement.

7—The generator is lubricated by splash from the timing gears. There is also an oil cup at the front end of the generator housing, and this should have a few drops of light oil each week.

#### The Cut-Out

The operation of cutting in and cutting out at suitable speeds is accomplished by the cut-out, which is mounted on the dash. This is set correctly at the factory and should need no other adjustment during its entire life.

#### The Charging Indicator

The charging indicator is on the instrument board. It registers "charge" when the generator is charging the bat-

tery and "discharge" when the lights are burning and the engine is not running at a greater speed than that corresponding to a car speed of 10 m.p.h. At a speed of over 15 m.p.h. the indicator should

3—With the generator running at a moderate rate of speed, take a pair of pliers or a screwdriver and short circuit the terminal stud on the generator to the generator housing.

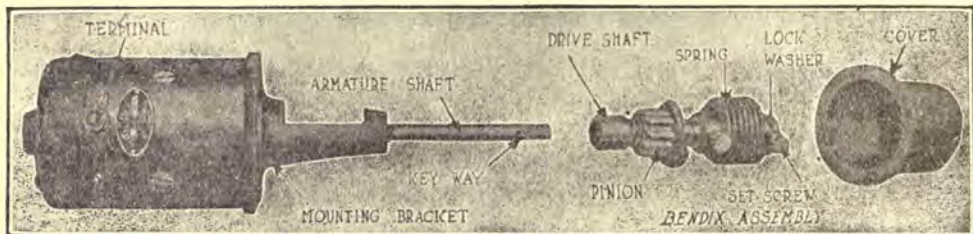


Fig. 3.—The starter with Bendix drive. The cover on the opposite side of the transmission cover allows room for the pinion to move

show a reading of 10 to 12 amperes with the lights burning. If the indicator does not show "charge" under such conditions,

1—Inspect the terminal posts of the indicator.

2—Disconnect the wire from the terminal on the generator.

4—If the generator is generating current, a good hot spark will be observed.

5—Inspect the wiring from the generator through the charging indicator to the battery.

#### Removing the Starting Motor

1—Remove the left engine pan.



2—Remove the four small screws which hold the shaft cover to the transmission cover. These can be taken off with a screwdriver.

3—Take off the gasket.

4—Turn the Bendix drive shaft around so that the set screw on the end of the shaft is in an upright position or on top.

5—There is a lock washer immediately under the set screw and it has lips or extensions on it opposite each other on the outside diameter. One of these is turned against the collar and the other against the side of the set screw.

6—Bend back the lip which has been forced against the screw and remove the set screw.

7—The lock washer will be broken or weakened and should be junked and replaced with a new one.

8—Pull the assembly out of the housing. *Do not lose the small key.*

9—Remove the four screws that hold the starter housing to the transmission cover.

10—Pull out the starter, taking it down through the chassis where the left engine pan was taken out.

11—In replacing the starter, reverse these operations and be sure that the terminal connection is at the top.

12—If the engine is to be operated without the starter, plates can be obtained from Ford branches to put over the holes to keep the oil from flying out.

### The Lights

The lighting system consists of two 2-bulb headlights operated by a combination lighting and ignition switch on the instrument board. The large bulbs are 6-8 volt, 17 c.p., and the small bulbs are 6-8 volt, 2 c.p. A small bulb, 6-8 volt, 2 c.p., is used in the tail lamp. All lamps are connected in parallel and the burning out of one lamp will not affect the others.

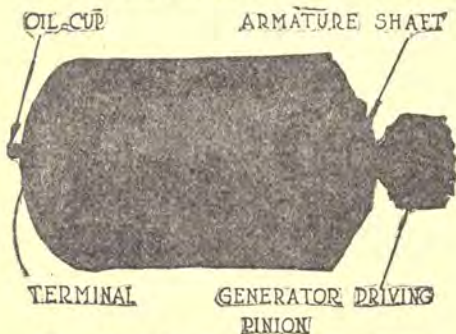
*Caution—Do not connect the lights to the magneto, as this will burn them out and may discharge the magneto magnets.*

The wiring and connections to the different lamps are shown in Fig. 2.

### Battery Care and Maintenance

The battery is a 6-volt, 13-plate Exide type 3-XC-13-1. The following points are to be observed in testing, adjusting and taking care of the battery:

1—Under no circumstances must the current from the battery be allowed to



*Fig. 4—The generator is driven from the large timing gear. It will be noted that the gears are spiral*

pass through the coils of the magneto. Current flowing through these coils even

for an instant would discharge the magnets and require the taking down of the engine and the installation of new magnets, not to speak of possible damage that might be done to the coils themselves. To guard against this, disconnect the positive wire from the battery before doing any testing or working around the wires and wrap this terminal with tape so that it cannot make contact with anything. As the negative terminal is grounded to the frame, this will prevent the current from going anywhere until the positive terminal is connected again.

1—Add nothing but distilled water to the battery. This filling should be done at least once a week on cars that get ordinary use, and oftener on cars that are used constantly. Water will evaporate more quickly in summer than in winter and replacement will therefore be necessary at more frequent intervals in warm weather.

2—Test the density of the electrolyte at frequent intervals to make sure that

the generator is keeping the battery charged. This is done by removing the filler cap of each cell in turn, sucking up some of the liquid with a hydrometer syringe and noting the number on the scale of the hydrometer that comes even with the top of the liquid.

A fully charged battery should read from 1.275 to 1.300.

A battery half charged will show a reading of 1.225 to 1.250.

A battery completely discharged will show a reading of less than 1.200.

3—Return the electrolyte to the cell from which it was taken and then proceed to the next one. The electrolyte of one cell must not be put in another cell.

4—Hydrometer tests must be taken after the battery has been charging. If the test is taken after adding water, the water will not have had a chance to mix thoroughly and the test will not show the true condition of the battery.

5—Continued operation of the car with the battery in a discharged condi-

tion will injure the battery. The cause of the run-down condition should be ascertained and fixed and the battery then charged from some outside source to bring it up to a fully charged condition.

6—Keep the filler caps in place and screwed down tight.

7—Keep the battery connections clean and tight. They should be coated with heavy grease or vaseline to protect the metal from the acid.

8—The battery must be secured firmly in place, and if the holddowns are loose, tighten them, as a loose battery will shift and jump around breaking the connections or damaging the insulation.

9—A voltmeter test of the cells should show 2.2 volts for each cell, or 6.6 volts for the three cells if the battery is fully charged. If the battery is discharged this voltage will drop to 1.75 volts per cell, or 5.25 volts for the three cells. The voltmeter reading is not as reliable or as accurate as the hydrometer for testing the condition of the battery, but it can be used as a check.

*Never connect an ammeter in circuit directly with the battery, as this will burn out the instrument or heat it so badly that it will be useless. It also imposes a severe drain on the battery.*

### Making Circuit Tests

Where there is trouble in the circuit due either to an open circuit or a ground, connect up a dry cell to a small electric light and run two leads off, one from the cell and one from the lamp. When these are touched together, the lamp should light. By attaching these wires to two ice picks, a simple but useful test set is made and this can be used to prod all

the terminals and wiring to locate the trouble.

If the lamp fails to light when the test points are placed at the terminals where there is supposed to be a complete circuit, there must be an interruption of some kind and by getting down closer with the test, the exact point can be located.

In the case of a ground, the battery will most likely be discharged when the car is brought into the shop and the battery terminal should be disconnected immediately to prevent further damage. The wiring can then be tested out at leisure, making use of the wiring diagrams in discovering the faults.

## CHAPTER XXVI

### Reading Wiring Diagrams, with Blueprints of 25 Internal and External Circuits Used on Ford Cars

**E**VERY car, every individual electrical system and every unit of a system will vary from other cars, systems and parts of systems in some details. The terminals come in different places, the terminals vary in number and the wires go in different directions. In order that the mechanic who is working on the car may understand very clearly just what he is doing, it is convenient to have a wiring diagram of the particular installation he is working on. This simply consists of a series of lines, each of which indicates a particular wire. Most of the units are conventionally represented so that by tracing the lines out with a pencil on the paper he can see where the wires start from and where they go to.

Every standard starting, lighting and ignition system must include the four following component parts:

1—Generator.

2—Storage battery.

3—Starting motor.

4—Spark plugs.

The generator is mechanically connected to the engine in such a way that all the time the engine is running, the generator is generating current which is used to charge the battery.

The storage battery serves as a means of storing up energy while it is available from the generator and then delivering it at such time as the generator may not be running.

The starting motor is a simple electric motor with windings especially adapted to the low voltage, high amperage current from the storage battery.

The ignition device transforms the electrical energy which is supplied by the battery, magneto, dry batteries or gen-

erator into heat energy or spark which is arranged to take place in the interior of the cylinder.







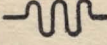








In addition to the units thus briefly described, there are any number of additional parts required to make all these perform their proper functions at the proper time. Some of these are wire, switches, connectors, ammeters, voltmeters, fuses, circuit breakers, automatic current and voltage regulators, lamps, sockets, etc.

In the blueprint section of this book are a number of wiring diagrams of different systems that have been adapted for use especially on the Ford car. Such diagrams permit the circuits to be traced much more easily than on the actual wiring of the car. Consequently the ability to read a wiring diagram is essential in locating troubles in circuits.

Certain conventional symbols have come to be used almost universally in wiring diagrams to represent the different pieces of apparatus and their connec-

tions. These are really shorthand pictures of the thing represented. They are not all standard, but some of them, such as the ground connection and the battery, are standard. Lamps, for example, may be represented by a circle, a bulb or the complete lamp assembly. The most usual symbols are shown on the page plate opposite.

In reading a wiring diagram, start to trace from some particular point and go through all the wiring till you get back to the point where you started. A complete circuit comes back to the same place where it started, if it can be said to start any particular place. If there is any break in this circuit it must be in the nature of some piece of apparatus that is capable of being closed at the proper time, such as a switch or a commutator. In most of the starting and lighting diagrams there will be at least a half dozen separate and distinct circuits. Some of these will be entirely separate and distinct from the others, and in some cases two or more circuits will use a common

-  Positive.
-  Negative.
-  Battery, either storage or dry cells.
-  Generator, Commutator and Brushes.
-  The proper method of showing a coil which surrounds an iron core but very seldom used on Delco Drawings.
-  The method used in showing a coil where there is no chance of confusion—Used in field coils, ignition coils, etc.
-  The method used to show resistance such as a resistance unit and charging resistances.
-  Contact points such as in switches, distributors, etc.
-  Ground connection where the wire is connected to the chassis, engine or generator.
-  Method used to show lighting switches.
-  Motor Commutator and brushes with brush lifting switch.
-  Primary and secondary windings of an ignition coil.
-  Condenser.
-  Crossed wires not connected.
-  A round dot on a circuit diagram usually represents a terminal for connecting a wire or wires.

wire. A little practice in tracing these things out will enable the mechanic to easily solve the problems of ignition wiring.

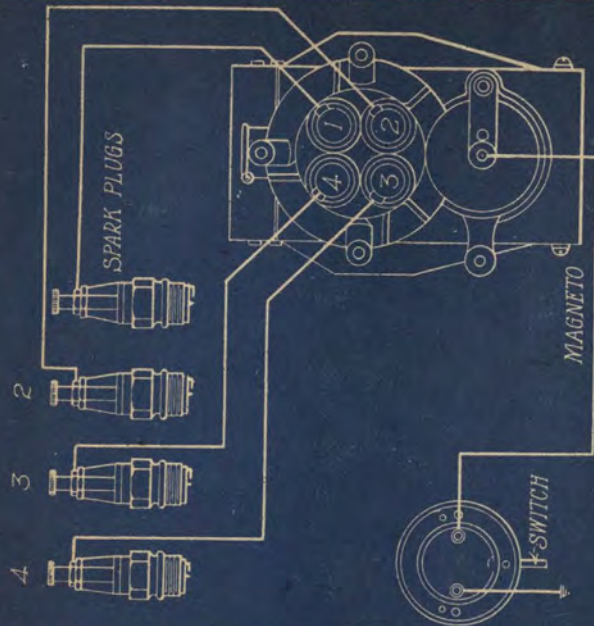
Most all diagrams that include switches, show the switches open, so that in tracing these wires, it is necessary to assume the switches closed and to jump these connections.

One thing that usually causes a lot of

trouble to those unused to reading wiring diagrams is the fact that the diagram does not usually show the parts in their relative positions that they occupy in the chassis. This is usually done to simplify the wiring lines so there will be the fewest possible number of lines and crosses to get from one part to another. Needless to say, if the parts are recognized, there will be no difficulty in tracing out the circuits.

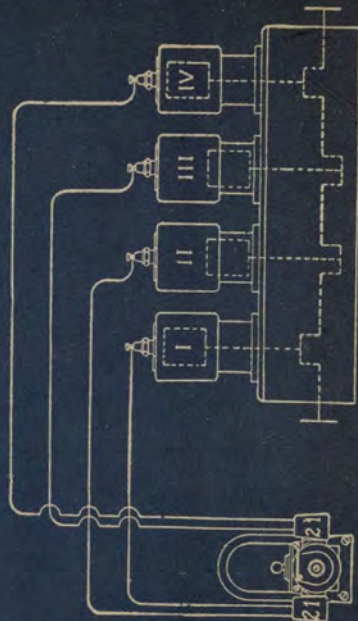


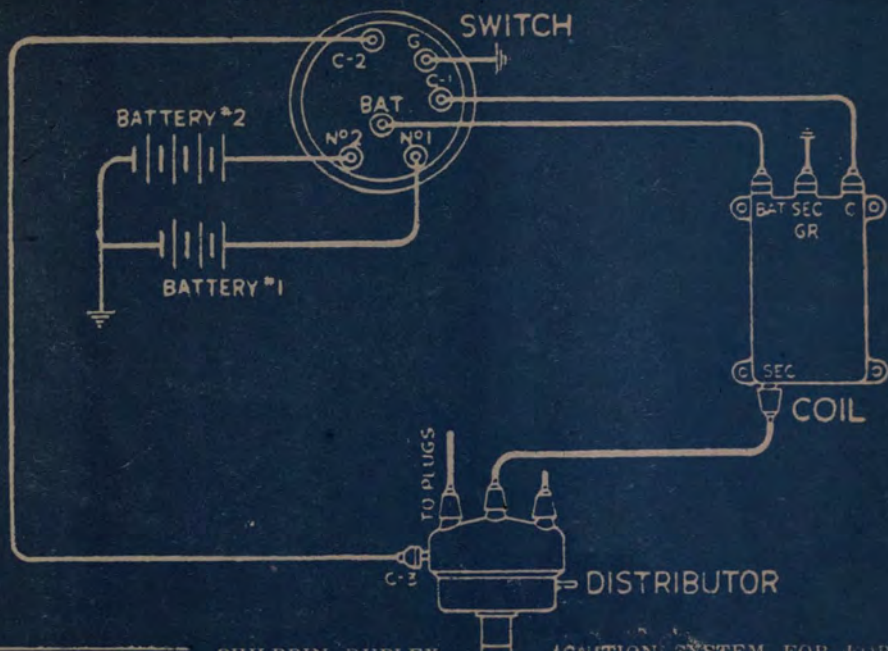


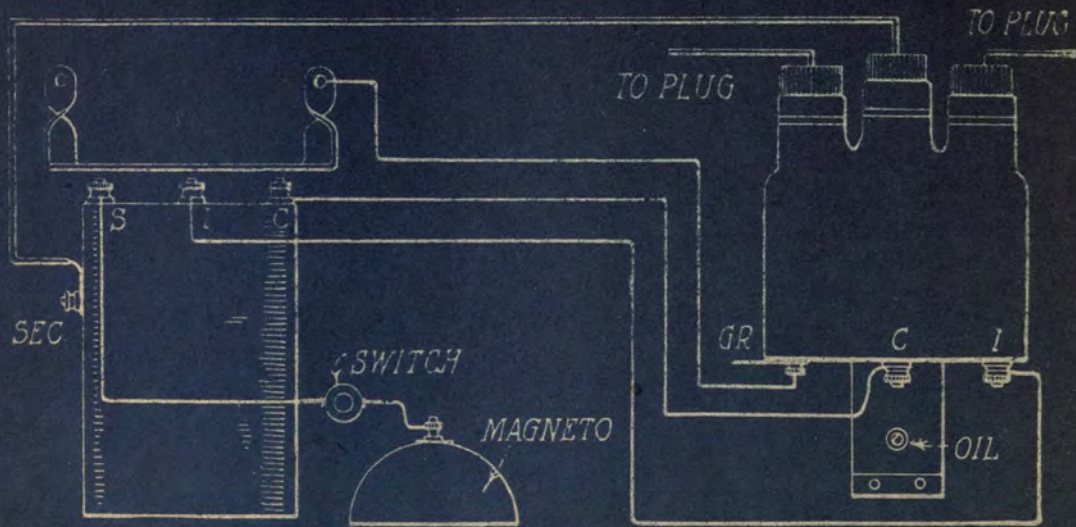


BOSCH DU4 GEAR DRIVEN MAGNETO FOR FORD

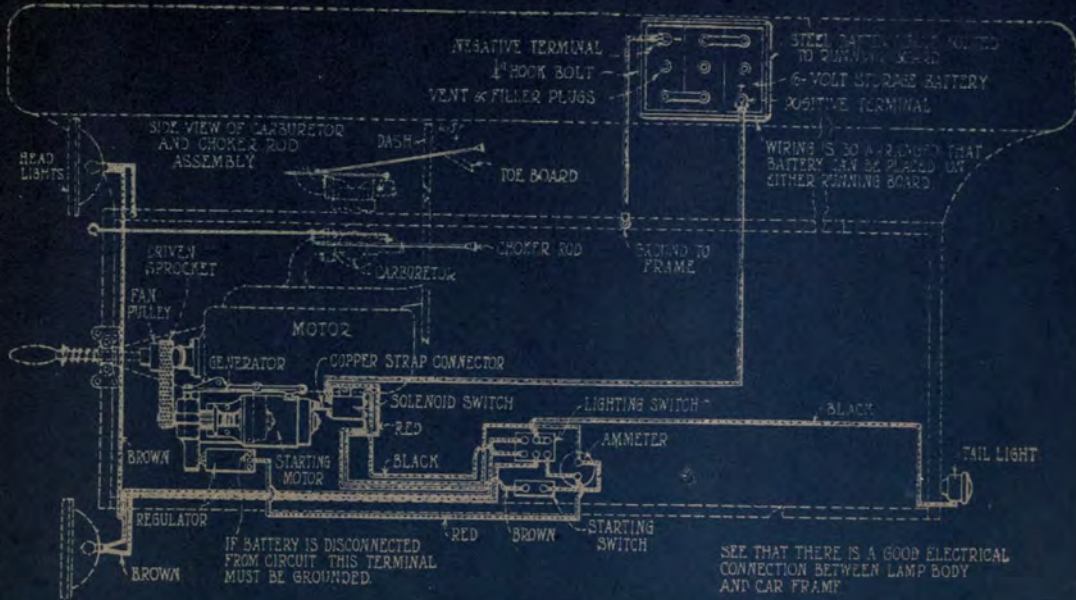
DIXIE MAGNETO IGNITION SYSTEM FOR FORD





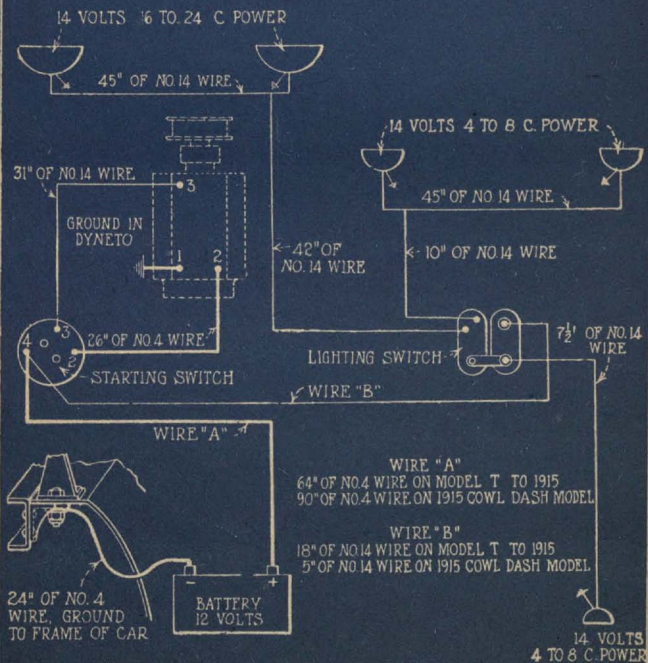


VIBRATOR-LES IGNITION SYSTEM FOR FORD

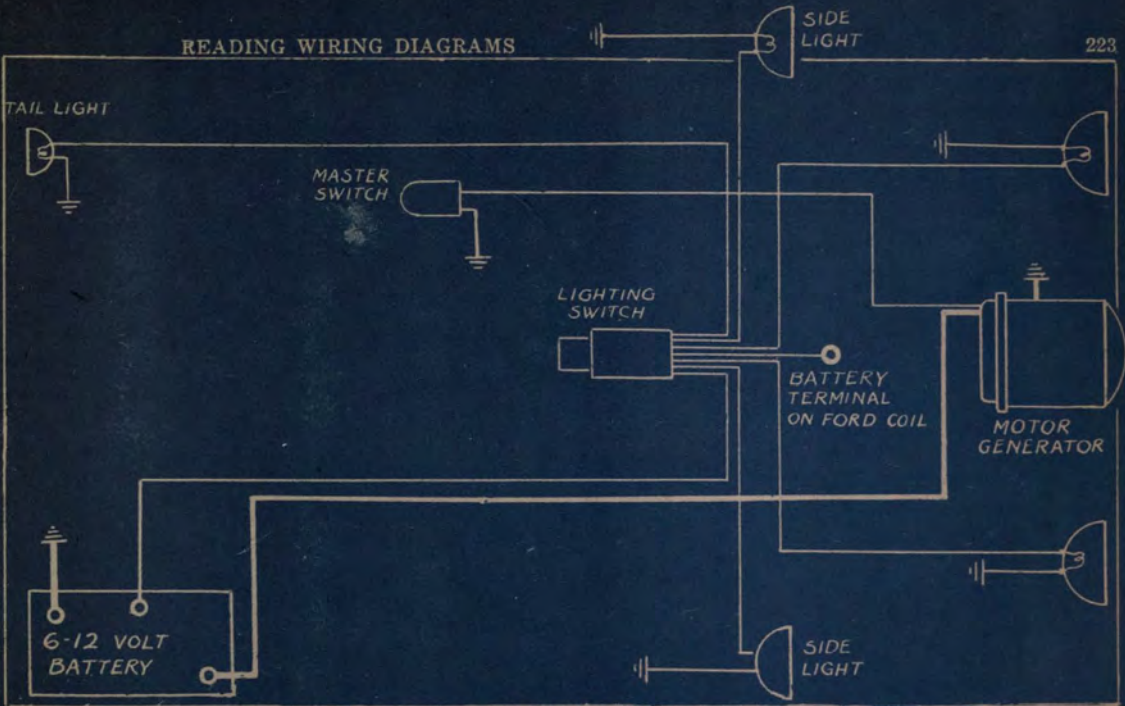


DISCO TWO UNIT STARTING AND LIGHTING SYSTEM FOR FORD

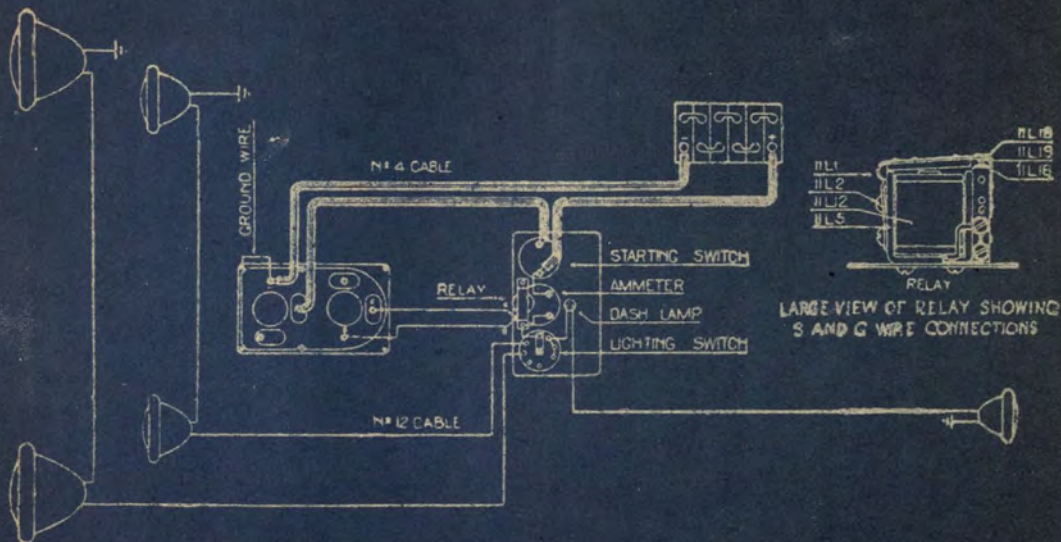
## MODERN METHODS OF FORD REPAIRING



DYNETO STARTING AND LIGHTING  
SYSTEM FOR FORD 1913-14



EVEREADY STARTING AND LIGHTING SYSTEM FOR FORD



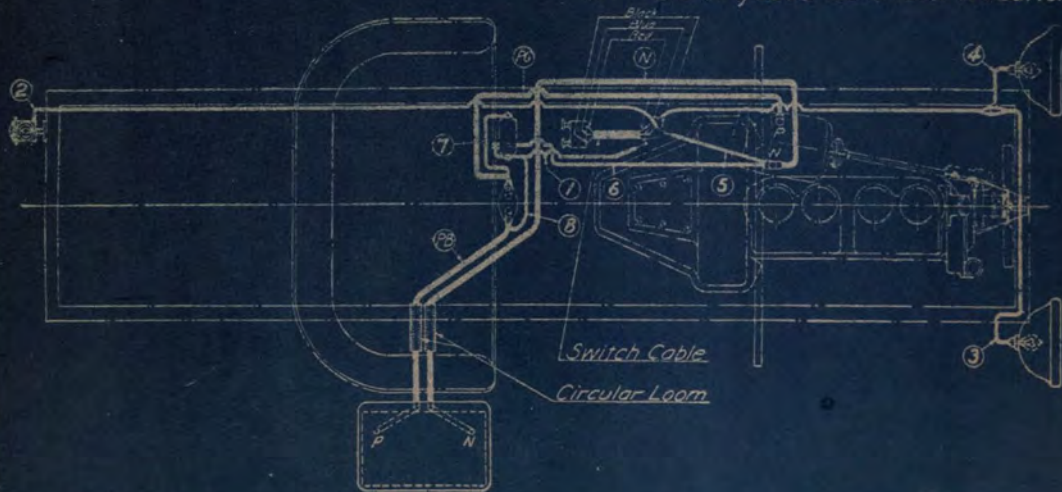
FISHER STARTING AND LIGHTING SYSTEM FOR FORD



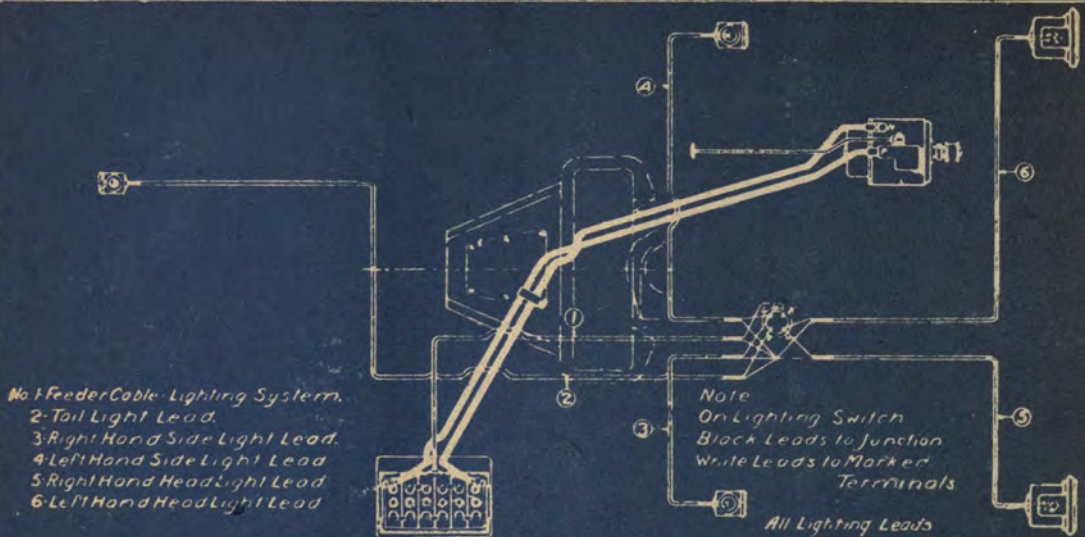
## READING WIRING DIAGRAMS

No: 1 - Feeder Cable - Lighting System  
 No: 2 - Tail Light Lead  
 No: 3 - Right Hand Head Light Lead.  
 No: 4 - Left Hand Head Light Lead.  
 No: 5 - Return Lead to Genemotor.

No: 6 - Shunt Lead to Cut Out.  
 No: 7 - Cut Out Jumper - Genemotor Side  
 No: 8 - Cut Out Jumper - Battery Side  
 P.G - Starting Lead - Genemotor to Switch  
 P.B - Starting Lead - Switch to "P" Battery  
 N - Starting Lead - Genemotor to "N" Battery



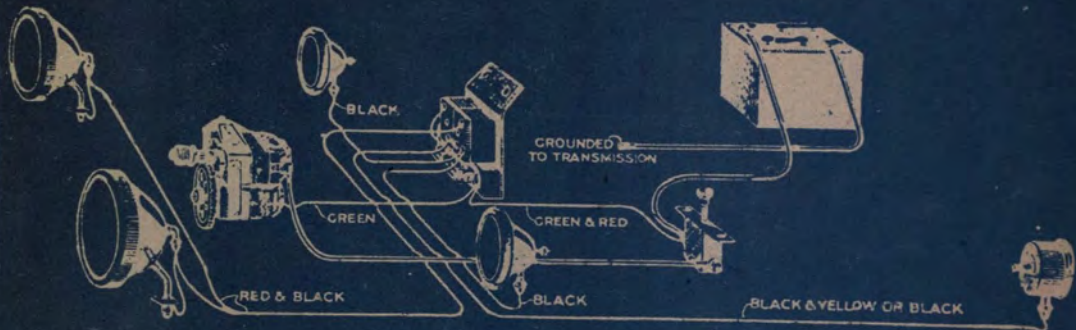
GENEMOTOR STARTING AND LIGHTING SYSTEM WITH SHAFT DRIVE



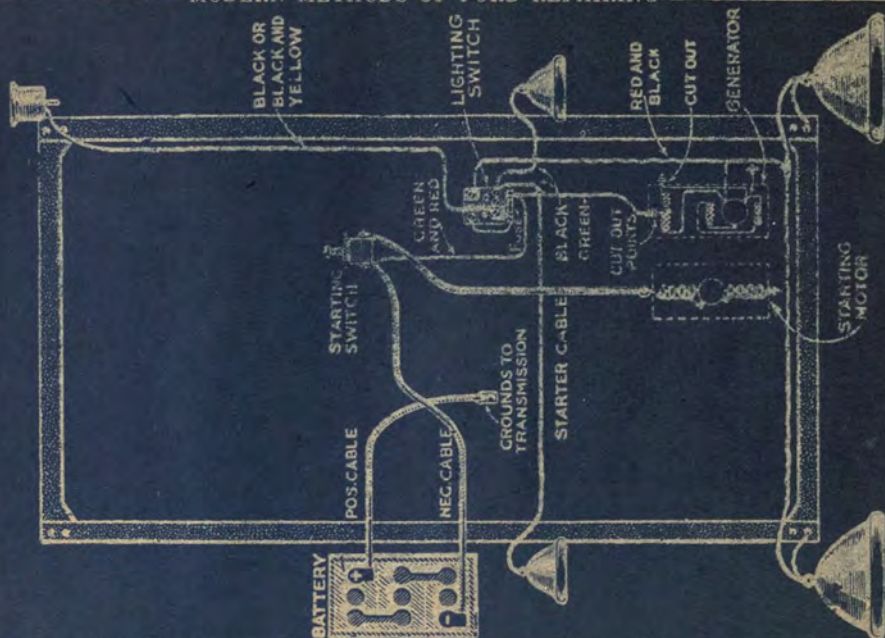
Connection Diagram.

G.E. Starting and Lighting System.

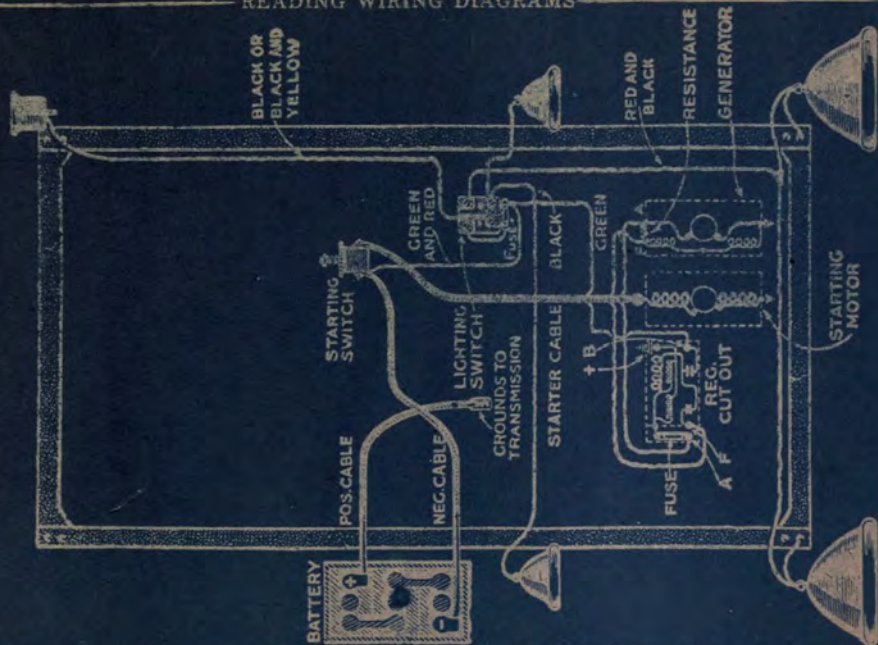
Ford Cars



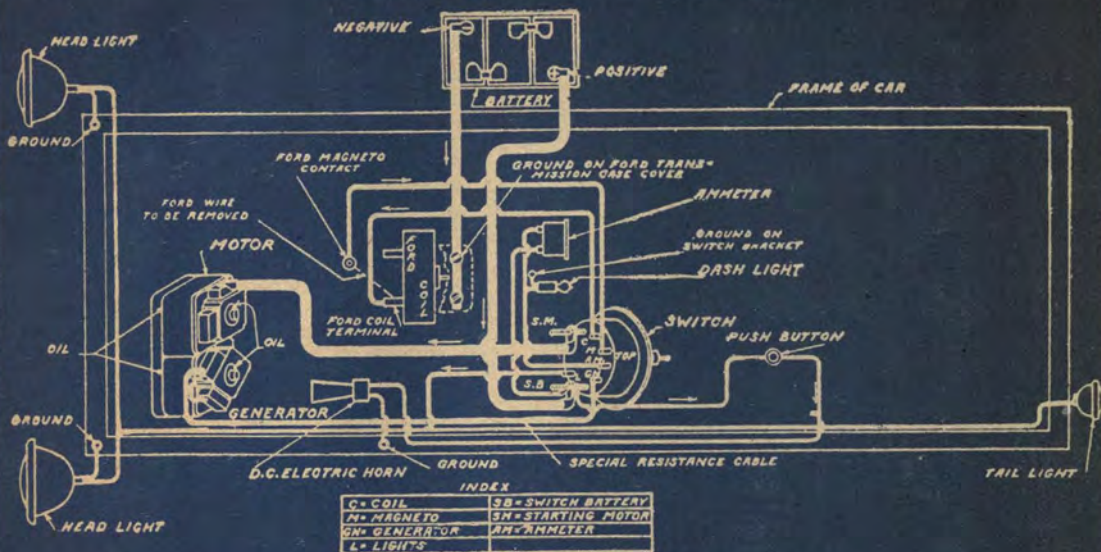
PERSPECTIVE VIEW OF GRAY & DAVIS SYSTEM ON FORD



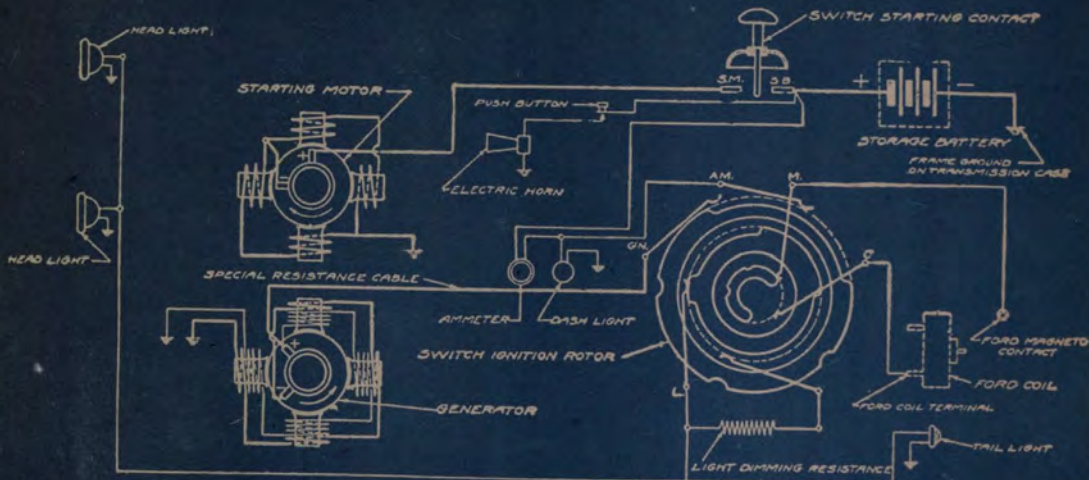
GRAY & DAVIS STARTING AND LIGHTING SYSTEM FOR FORD, THIRD BRUSH REGULATION



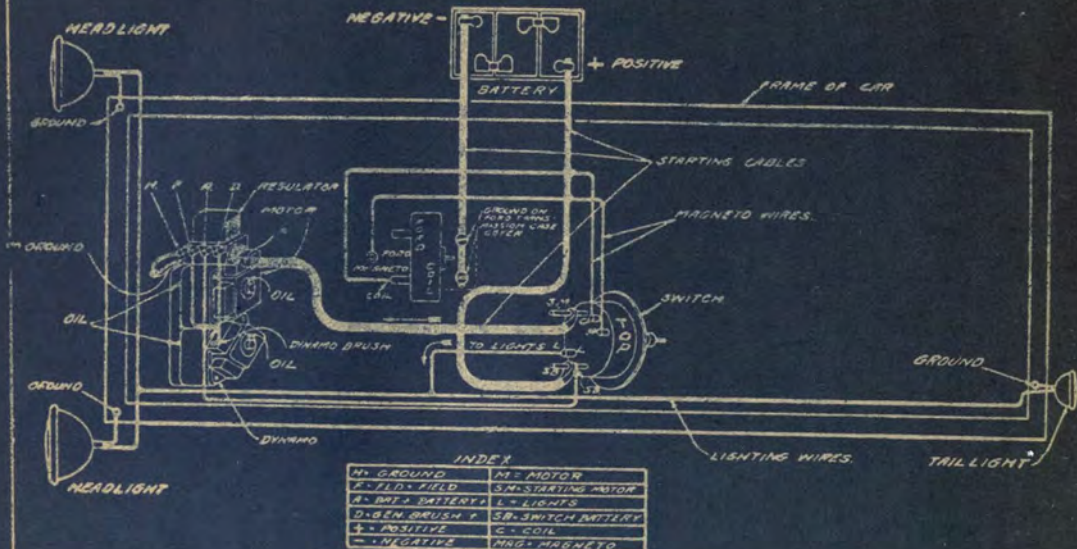
GRAY & DAVIS ELECTRIC STARTING AND LIGHTING SYSTEM FOR FORD  
ELECTROMAGNETIC REGULATION



HEINZE-SPRINGFIELD, MODEL 33, STARTING AND LIGHTING SYSTEM FOR FORD, GENERATOR REGULATION BY BUCKING FIELD COIL

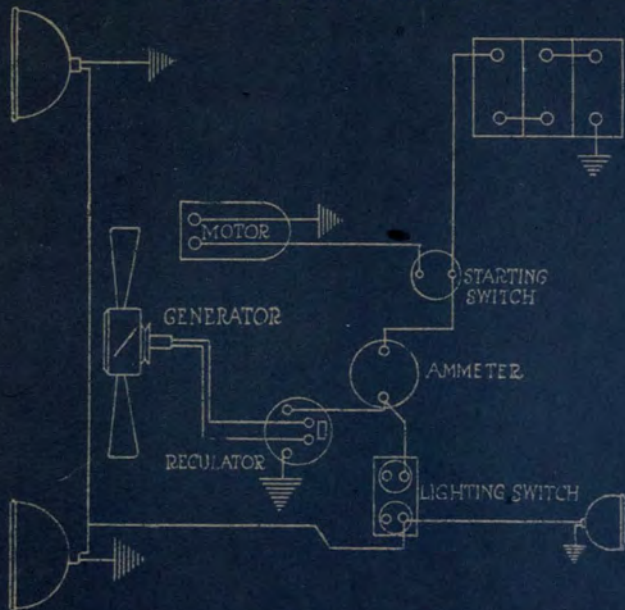


HEINZE-SPRINGFIELD, MODEL 33. INTERNAL CONNECTIONS

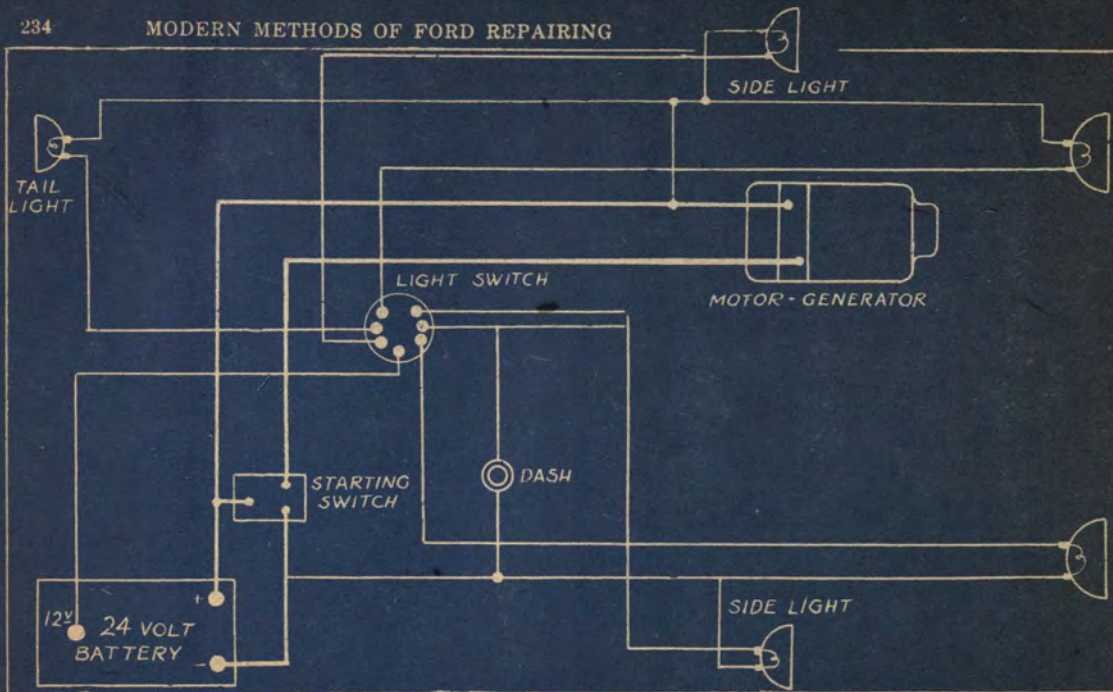


HEINZE-SPRINGFIELD STARTING AND LIGHTING SYSTEM WITH ELECTRO-MAGNETIC REGULATION

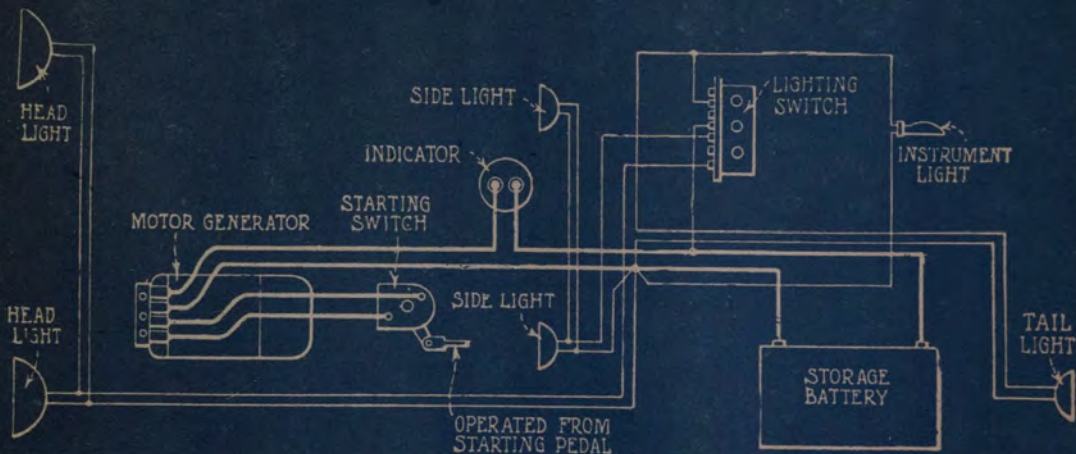




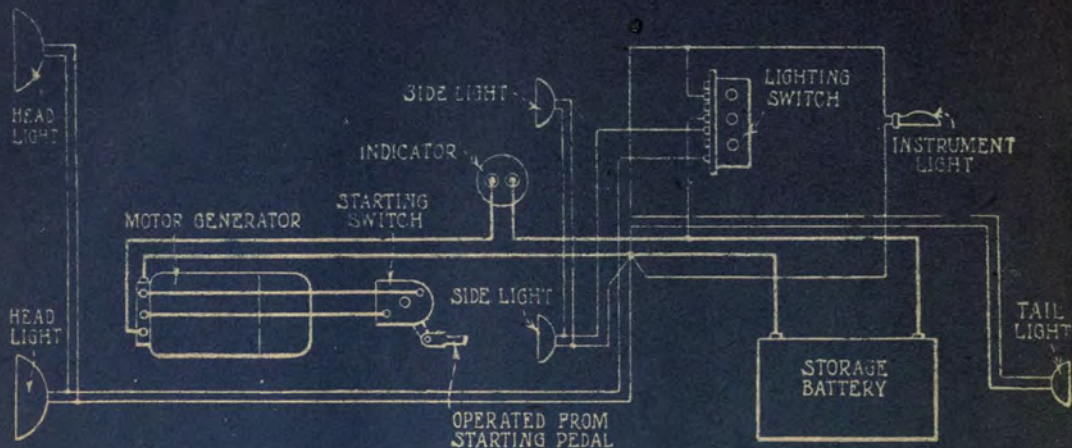
KEMCO STARTING AND LIGHTING SYSTEM FOR FORD



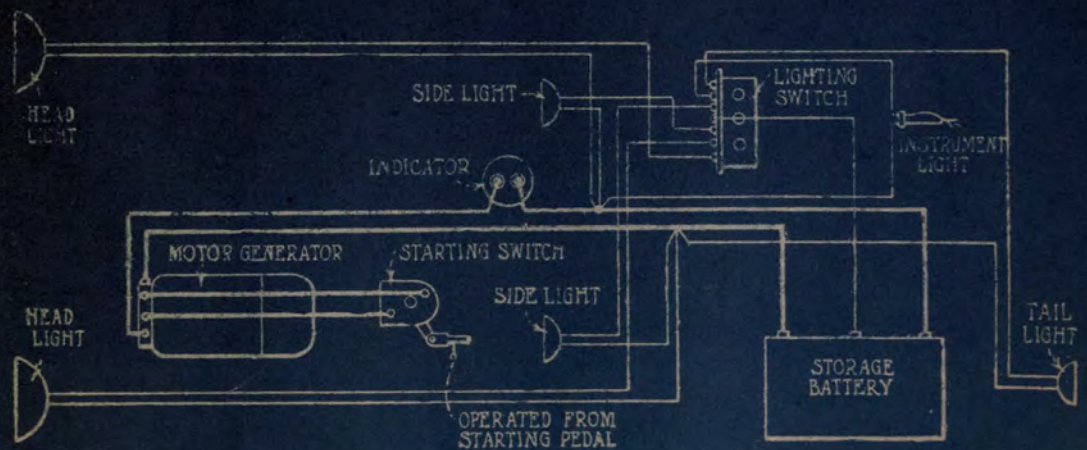
LEECE-NEVILLE STARTING AND LIGHTING SYSTEM FOR FORD



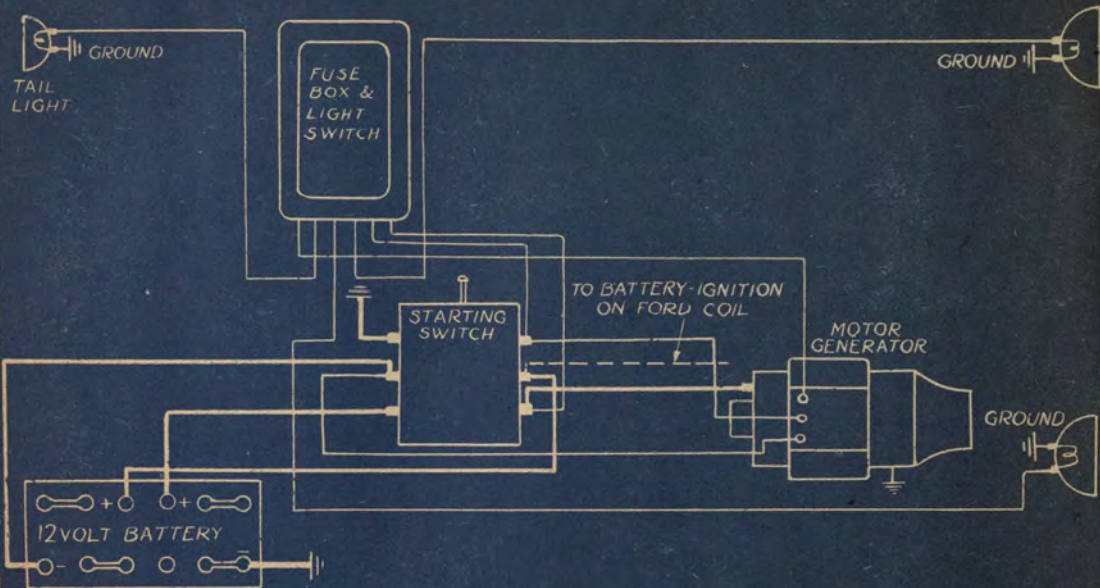
NORTH EAST FLEXIBLE LEAD STARTING AND LIGHTING SYSTEM FOR FORD

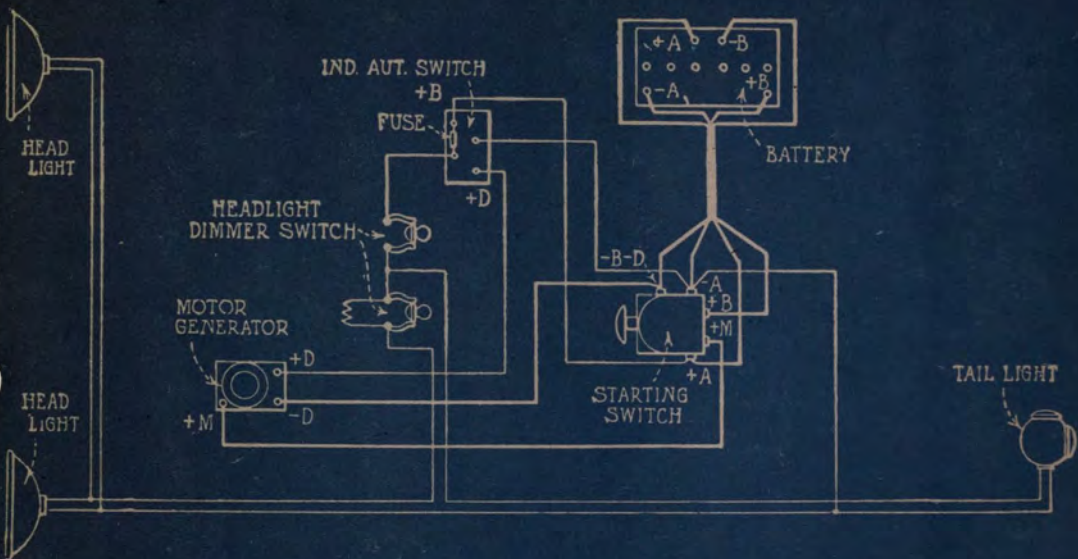


NORTH EAST BINDING POST TYPE STARTING AND LIGHTING SYSTEM FOR FORD

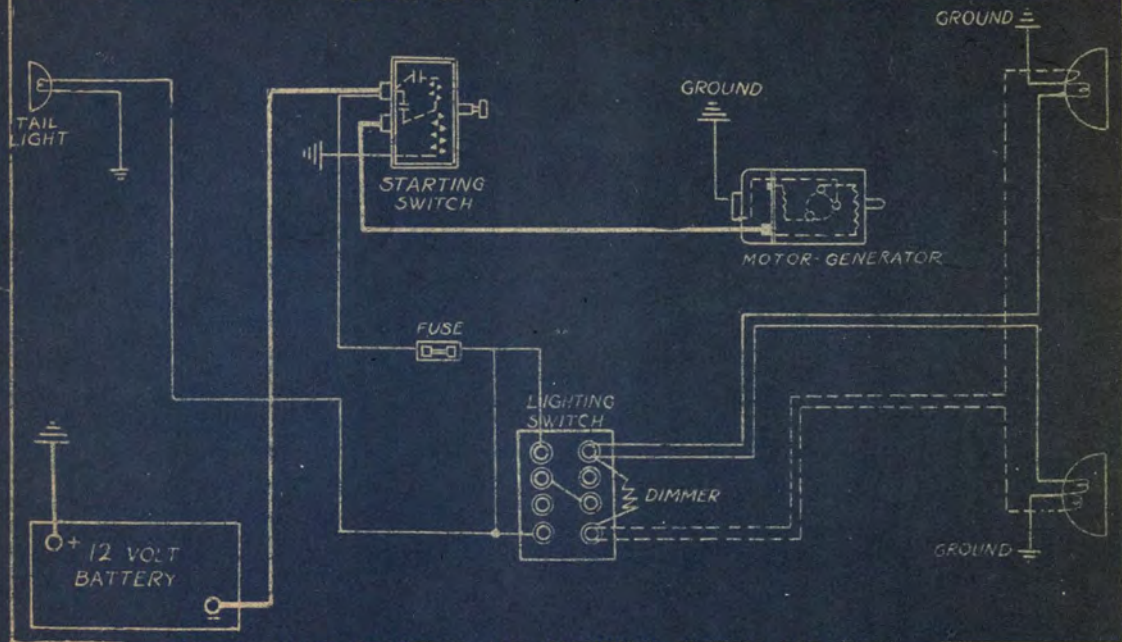


NORTH EAST 1913-14 STARTING AND LIGHTING SYSTEM FOR FORD





SPLITDORF STARTING AND LIGHTING SYSTEM FOR FORD



WESTINGHOUSE STARTING AND LIGHTING SYSTEM FOR FORD



# Index

## A

	PAGE
Acids, soldering.....	168
Aligning connecting rod.....	59
Alignment jig, connecting rod.....	59
— Front wheel.....	185
Arbor press.....	99, 100
— press tools, transmission.....	98
Assembly of engine and transmission.....	128
— of transmission drums.....	102
Atwater-Kent ignition system for Ford.....	217
Automatic switch, magnet tester.....	83
Axle, front, assembly.....	175
—, —, straightening.....	184
— shaft, broken.....	196

## B

Babbitt, melting.....	46
Babbitting bearings.....	46
Ball caps, steering gear.....	199
— race reamer, inner and outer.....	182
Balls, front wheel.....	180
Bands, transmission.....	107
Bar, front axle bending.....	184
Battery, care and maintenance.....	209
Bearing adjustment, front wheel.....	180
—, caps, burning in.....	74
—, knocks.....	160

Bearing, races.....	180
— rock, burning in.....	74
Bearings, blow holes.....	47
—, burning in.....	68
—, main.....	41
—, reaming.....	48
—, scraping.....	48
Bench, rear axle.....	189
Bending bar, front axle.....	184
— —, timer rod.....	148
— tool, connecting rod.....	59
Blow holes, bearing.....	47
Bolt, spindle.....	182
Bore, micrometer measurement.....	52
Boring mill.....	49
— tool, cylinder.....	51
Bosch DU4 gear driven magneto for Ford.....	218
Boxes, junk and salvage.....	14
Brake, adjustment.....	138
—, ratchet wrench.....	138
— shoes, worn.....	195
Brake-drum bushing driver.....	98
Brazing crankcase arms.....	114
Burning-in bearings.....	68
—, cool cap.....	77
—, machine.....	73, 69
—, — clutch.....	78
—, —, driving head.....	76

Burning-in, machine, power required.	69
—, —, pulleys	79
—, —, speed	69
—, time required.	68, 76
Bushing reamer, spring.	182
Bushing, starting crank.	114
Bushings, camshaft.	112
—, piston pin.	57
—, spindle	180, 182
—, steering connecting.	185
—, transmission	99
—, triple gear.	99

## C

Camshaft, aligning.	112, 113
— bushing reamer.	112
— bushings, replacing.	112
— testing	112, 113
Carbon, removal from ring grooves.	66
Carbureter, adjusting.	116, 118, 126
—, float clearance.	127
—, — gage	119, 120
—, gasoline level.	120, 127
—, Holley (float).	119, 120
—, inlet needle seat tool.	122
—, Kingston float.	127
—, low speed hole.	125
—, — tube	124
—, needle valve.	126

Carbureter, straightening tube.	124
—, throttle plate.	126
—, — rod	126
Cashier, duties of.	12
Charging indicator operation.	207
Claim check.	9
Clamping device, drum.	102, 103
Clearance, piston.	56
Clutch adjustment.	106
—, burning-in machine.	78
— disks, assembly.	105
—, examination	99
— neutral for testing.	158
— push ring.	105
— ratchet wrench.	138
— release ring.	108
— shaft	108
— shift	105
— spring	105
Coil box.	139
— unit testing machine.	142, 143
— — terminals, testing.	145
— units	139
—, testing	91
—, — and adjusting.	143
—, wet	144
Coils engine testing set.	155
— magneto, repairing.	94
—, testing.	92

- Commutator (See Timer).....146  
 Compression, loss of.....161  
 Condenser, punctured.....144  
 Connecting rod, aligning.....59  
 — alignment jig.....59  
 —, bending tool.....59  
 —, — bearing caps, marking.....39  
 — bearings, burning-in.....68, 80  
 Cotter pin box.....28  
 Crankcase arms, brazing.....114  
 — bolts, removing.....39  
 — nose.....129  
 — testing.....115  
 — and transmission cover assembly...136  
 — and transmission cover gaskets...136  
 Crank handle, loose.....129  
 —, ratchet.....129  
 Crankshaft endplay.....128  
 —, press.....44  
 —, straightening.....43  
 —, testing.....43  
 —, testing gage.....44  
 Cut-out operation.....207  
 Cylinder block clamps.....36  
 —, rebabbiting.....46  
 — stand.....40, 41  
 —, crack in.....161  
 — head bolts, removing.....35  
 — head, removing.....35  
 Cylinder lap.....55  
 Cylinders, reboring.....49, 51
- D
- Department arrangement.....13  
 Differential, lubrication.....193  
 Disco two unit starting and lighting  
 system for Ford.....221  
 Disks, clutch, examining.....99  
 Dixie magneto ignition system for  
 Ford.....218  
 Drive shaft, disassembly.....191  
 Driven gear puller block.....98  
 — gear sleeve bushing reamer.....97  
 Driver, brake drum bushing.....98  
 —, reverse drum bushing.....98  
 —, slow speed bushing.....98  
 Drivers Front Wheel inner ball race.182  
 — — — outer ball race.....182  
 — inner and outer ball race remover.182  
 — spindle arm bushing.....182  
 — body bushing.....183  
 — — — bracket.....182  
 Driving head, burning-in machine...76  
 — plate bushing reamer.....97  
 Drum clamp.....103  
 Dust washers, front wheel.....179  
 Dyneto starting and lighting system  
 for Ford 1913-14.....222

## E

Electrodes, spark plug.....	146
Engine division labor charges.....	15
— lifting tongs.....	38
— lubrication .....	161
— noises .....	159
— numbers .....	170
— pans, removal.....	28
— running-in .....	155, 156, 157, 159
— stand, metal.....	34
— —, wood .....	32, 33
— starting with electric starter.....	203
— taking down.....	31
— test stand.....	150, 156, 157
— testing .....	150
— — and running-in stand.....	151
— tongs .....	29, 150
— and transmission assembly.....	128
— turning over.....	134
Eveready starting and lighting system for Ford.....	223
Exhaust manifold, removal.....	28
— pipe for testing engine.....	154
— — pack nut.....	28

## F

Fan belt, taking off.....	31
— shaft bracket.....	31
Feed pipe, gasoline.....	202

Field coil assembly, removing.....	38
Fisher starting and lighting system for Ford.....	224
Fitting pistons.....	54
Flywheel, removing.....	38
— stand .....	104
Front axle assembly.....	175
— — bending bar.....	184
— — stand .....	178
— — straightening .....	184
— — template .....	184
— end hook.....	176
— radius rod ball cap.....	30
— universal ball cap.....	96
— wheel, balls.....	180
— — ball race drivers.....	182
— wheels, bearing adjustment.....	180
— —, lining up.....	185
Fuel inlet valve, Holley.....	121

## G

Gage, crankshaft.....	44
— feeler for burning-in.....	74
Gaskets, crankcase and transmission cover .....	136
Gasoline feed pipe.....	202
—, for engine testing.....	155
—, strainer .....	202
— tank .....	200

Gear distance.....	47
— noises-timing .....	160
Genemotor starting and lighting system with chain drive.....	226
Genemotor starting and lighting system with shaft drive.....	225
Generator, mounting on engine.....	204
—, troubles and remedies.....	205
Gray & Davis electric starting and lighting system for Ford, electromagnetic regulation.....	229
Gray & Davis starting and lighting system for Ford, third brush regulation .....	228
Grinding bearing caps.....	74
— compound, cylinder.....	55
—, valve .....	130

## H

Heinze-Springfield Model 33 internal connections .....	231
Heinze-Springfield Model 33 starting and lighting system for Ford, generator regulation by bucking field coil.....	230
Heinze-Springfield starting and lighting system with electromagnetic regulation .....	232

Helper, engine work.....	25
Holley fuel inlet valve.....	121
— spray nozzle.....	123
— — — tool .....	123
Hook, front end.....	176
Hose clamps removal.....	26
Hub cap removal.....	177
Hubs, removing from wheels.....	179

## I

Ignition, wiring assembly.....	141
— — diagram .....	141
— system .....	139
— test coils.....	155
Inlet needle seat tool.....	122
Instruction card.....	7, 9
Intake manifold, removal.....	27

## J

Jew socket wrench for crankcase bolts	37
— — —, for differential flange nuts..	194
Jig, connecting rod aligning.....	59
—, for steering gear ball caps..	198, 199
—, — transmission band linings.....	108
—, triple gear riveting.....	103
—, piston .....	57
Junk box.....	14

<b>K</b>		Magnets, assembling.....	85
Kemco starting and lighting system		Magnet, assembly.....	88
for Ford.....	233	— improperly placed.....	87
Knocks, connecting rod.....	160	— locking wire.....	89
—, main bearings.....	160	— polarity .....	86
—, piston .....	160	— remagnetizing .....	85
<b>L</b>		— replacement assemblies.....	90, 91
Labor operations, prices.....	12	— strength .....	83
Lapping, cylinder.....	55	— test weight.....	83, 84
Leece-Neville starting and lighting		— testing instrument.....	81, 82
system for Ford.....	234	Main bearing caps, marking.....	39
Lighting system, care and repair...	203	— bearings .....	41
Line reamer, camshaft bushing.....	112	—, burning-in .....	68
Lining reamer for spindle bushings..	182	—, reaming .....	48
— up front wheels.....	185	Micrometers.....	52, 53
Low speed hole, carbureter.....	125	Motor, mounting on Engine.....	204
Lubrication, engine.....	161	— shifting mechanism.....	157
<b>M</b>		Muffler .....	200, 201
Machine, burning-in.....	73	<b>N</b>	
Magneto, Bosch DU4 gear driven, for		Needle assembly, carbureter.....	122
Ford .....	218	— seat tool, inlet.....	122
— clearance .....	128	North East binding post type starting	
— coil support shim.....	129	and lighting system for Ford...	236
— coils, repairing.....	94	— — flexible lead starting and light-	
—, testing .....	92	ing system for Ford.....	235
—, Dixie ignition system for Ford...	219	— — starting and lighting system	
—, testing and overhauling.....	81	for Ford 1913-14.....	237
Magnet pole pieces.....	85	Numbers, engine,.....	170

## O

Oil, draining.....	31
— leakage, preventing.....	135
— level, engine.....	161
— pipe, removing.....	39
Old material, disposition.....	13
Open circuit, test for.....	92
Oversize pistons.....	49
— piston rings.....	67
Oxy-acetylene welding outfit.....	167

## P

Parts box.....	25
Perspective view of Gray and Davis system on Ford.....	227
Philbrin duplex ignition system for Ford .....	219
Pinion gear press, rear axle.....	191
Piston clearance.....	56
— jig .....	57
— pin, bushing reamer.....	58
— —, bushings.....	57
— —, fitting .....	57
— ring, groove tool.....	66
— — tool .....	64
— rings fitting.....	63
— — oversize .....	67
— — tapered .....	63
— sticking .....	160

Piston vise.....	60
Pistons, fitting.....	54
—, lapping .....	55
—, marking .....	39
—, oversize .....	49
Planet gear bushing reamer.....	97
Plugs, testing.....	144, 145
Pole pieces, magnet.....	85
Porcelain spark plug.....	146
Porter .....	12
Prices, labor operations.....	12
Puller block, driven gear.....	98
—, rear wheel.....	189
Pulleys, burning-in machine.....	79
Push rods.....	130
— rod hole reamer.....	114

## R

Races, bearing.....	180
Radiator, draining.....	25
—, leaks and causes.....	162
—, removing .....	26
—, repairs .....	168
—, repair tubes.....	168
—, springs .....	169
—, stay rod removal.....	26
—, straightening .....	168
—, stud bolt nuts, removal.....	26
—, testing .....	166

Radiator, testing outfit.....	162	Rear axle combination stand.....	193
—, test plugs.....	163, 164	—, disassembly .....	190
—, testing tank.....	162	—, jack and truck.....	194
Radius rod ball cap, front.....	30	—, overhauling time.....	195
—, replacement .....	185	—, pinion gear press.....	191
Ratchet, crank handle.....	129	—, sleeve puller.....	192
— wrench, clutch and brake.....	138	—, speed wrenches.....	195
Reamer, camshaft bearing bushing..	114	Rear end hook.....	186, 188
—, crankshaft bushing.....	112	Rear wheel puller.....	189
—, driven gear sleeve bushing.....	97	Rear wheel removal.....	177, 187
—, driving plate bushing.....	97	Rebabbiting cylinder block.....	46
—, lining for spindle bushings.....	182	Reboring cylinders.....	49, 51
—, piston pin bushing.....	58	Remagnetizing magnets.....	85
—, planet gear bushing.....	97	Removing cylinder head.....	35
—, push rod hole oversize.....	114	— — bolts .....	35
—, reverse gear bushing.....	97	— transmission cover.....	35
—, slow speed gear bushing.....	97	— valves .....	35
—, spindle bushing.....	179	Repair order.....	7, 8, 9, 10
—, spring bushing.....	182	— tubes, radiator.....	168
—, steering bracket bushing.....	130	Replacing crankshaft bushings.....	112
—, starting crank bushing.....	130	Reverse adjustment.....	138
—, transmission .....	97	— drum bushing driver.....	98
—, triple gear bushing.....	98	— gear bushing reamer.....	97
—, valve stem guide.....	114	— ratchet wrench.....	138
Reaming main bearing.....	48	Rings, piston.....	63
— trasmission drums.....	101	Rivets, triple gear.....	99
Rear axle assembly.....	186	Rock, bearing for burning-in.....	74
— — bench, wood.....	189	Running in engine....	155, 156, 157, 159



## S

- Salvage box..... 14
- Scraper, bearing cap..... 74
- Scraping bearings..... 48
- Segregation of work..... 12
- Service manager, duties of..... 12
- Shim, magneto coil support.....129
- Simms-Huff starting and lighting system for Ford.....238
- Shop foreman, duties of..... 12
- Short circuit, test for..... 94
- Slow speed hand adjustment.....138
- — bushing driver..... 98
- — gear bushing reamer..... 97
- Socket jew wrench for differential flange nuts.....194
- Soldering acid.....168
- Spark plug electrodes.....146
- —, gap.....146
- —, porcelain.....146
- —, size.....146
- —, testing.....144, 145, 146
- Speed wrench, crankcase nut..... 27
- —, flange nut.....190
- —, how to use..... 37
- —, radiator nut..... 26
- —, rear axle.....195
- —, torque tub retaining nut.....190
- Spindle arm bushing driver.....182
- Spindle body bushing.....180
- — —, driver.....182
- bolt.....180, 182
- bolt removal.....181
- bushing reamer.....179
- Splitdorf starting and lighting system for Ford.....239
- Spray nozzle, Holley.....123
- —, tool, Holley.....123
- Spring bushing reamer.....182
- clutch..... 96
- repairs, front.....182
- Springs, radiator.....169
- Stand, cylinder block.....40, 41
- , engine, metal..... 34
- , engine running in and testing...151
- , flywheel.....104
- , front axle.....178
- , rear axle.....193
- Starting and lighting, care and repair 203
- crank bushing.....114
- crank bushing reamer.....130
- motor, removing.....208
- Steering bracket bushing reamer...130
- connection bushings.....185
- gear.....197
- — adjustment.....200
- — ball caps.....199

Steering wheel.....	197
— — removal .....	198
Stock clerk, duties of.....	12
Strainer, gasoline.....	202
Strangling tube, carburetor.....	124
Switch .....	149
System in service.....	7

## T

Taking down engine.....	41
Tank, gasoline.....	200
Template, front axle.....	184
Terminals, setting up.....	149
Test points, ignition system.....	91, 92
Tester .....	12
Testing magnet strength.....	82
— the engine .....	150
— stand, engine.....	157
Timer.....	146, 147
— advance device.....	161
— rod bending bar.....	148
— troubles .....	147
Timing gear case, removing.....	31
— — noises .....	160
—, valve .....	114
Tongs, engine lifting.....	29, 38
Tools, arbor press for transmission..	98
Torque tube retaining nut speed wrench .....	190

Towing device, broken axle.....	196
Transmission, arbor press tools.....	98
— band lining jig.....	108
— bands, assembly.....	107
— —, holding jig.....	107
— —, lining material.....	106
— —, relining .....	106
— bushings .....	99
— cover gaskets.....	136
— — packing .....	135
— — removal .....	35
— drum assembly.....	102
— — clamps .....	102
— — support .....	101
— overhauling .....	96
— reamers .....	97
— rebushing drums.....	96
— turning bar.....	105
Triple gear bushings.....	99
— — bushing reamer.....	98
— — rivets .....	99
— gears, riveting.....	103
— gear riveting jig.....	103
Tubes, radiator repair.....	168
Turning bar, transmission.....	105

## U

Units, coil.....	139
—, —, adjusting and testing.....	143

